

MICHIGAN STATE

U N I V E R S I T Y

The Capstone Experience

Dr. Wayne Dyksen

Department of Computer Science and Engineering
Michigan State University
Fall 2014



*From Students...
...to Professionals*

Course Goals

- Build a Significant Software System
- Work in a Team Environment
- Learn New Tools and Environments
- Build and Administer Systems
- Develop Communication Skills
- Develop Interview Talking Points
- Consider Issues of Ethics and Professionalism



Course Goals

- Teams of Students
- Build Significant Software System
 - Design
 - Develop
 - Debug
 - Document
 - Deliver
- For Corporate Clients
- In 15 (Short) Weeks



Project Deliverables

- Project Plan Document & Presentation
- Alpha Presentation
- Beta Presentation
- Project Software & Documentation
- Project Video
- Design Day

See [Major Milestones](#).



All-Hands Meetings

- MW, 3:00-3:50pm, 2400 Engineering Building
- Presentations By
 - Professor
 - Teams
 - Status Reports
 - Formal Presentations
 - Project Plan
 - Alpha
 - Beta
 - Project Videos
 - Guest Speakers



All-Hands Meetings

08/27: Capstone Overview
09/01: (Labor Day, No Meeting)
09/03: Project Plan
09/08: Risks and Prototypes
09/10: Team [Status Report Presentations](#)
09/15: Team [Project Plan Presentations](#)
09/17: Team [Project Plan Presentations](#)
09/22: Team [Project Plan Presentations](#)
09/24: Team [Project Plan Presentations](#)
09/29: Resume Writing and Interviewing
10/01: [Career Gallery](#)
10/06: Schedule and Teamwork
10/08: Creating and Giving Presentations
10/13: Team [Alpha Presentations](#)
10/15: Team [Alpha Presentations](#)
10/20: Team [Alpha Presentations](#)
10/22: Team [Alpha Presentations](#)

10/27: [Design Day](#) and the [Project Videos](#)
10/29: Camtasia Demo
11/03: Team Beta Presentations
11/05: Team Beta Presentations
11/10: Team Beta Presentations
11/12: Team Beta Presentations
11/17: Team Status Reports
11/19: Team Status Reports
11/24: Team Status Reports
11/26: Team Status Reports
12/01: [Project Videos](#)
12/03: [Project Videos](#) and [All Deliverables](#)
12/04: [Design Day Setup](#)
12/05: [Design Day](#)
12/09: [Project Videos](#)



MICHIGAN STATE

UNIVERSITY

The Capstone Experience

Team Amazon

Department of Computer Science and Engineering
Michigan State University

Fall 2014



*From Students...
...to Professionals*

amazon





Shop by Department

Search

All

Go

Hello. Sign in Your Account

Try Prime

Cart

Wish List

INTRODUCING

fire PHONE

THE ONLY SMARTPHONE WITH MAYDAY

LEARN MORE



amazon fireTV

ONLY \$99

> Shop now



fire PHONE

LIMITED-TIME OFFER

INCLUDES A FULL YEAR OF PRIME

LEARN MORE

Team Amazon

Project Overview

Twitter Trending Effects on Amazon Sellers

- Functionalities
 - Alert Amazon Sellers Re
 - Brands Trending
 - Consumers' Sentiments
 - Based on Twitter Tweets
- Features
 - Consume Real-Time Twitter Stream
 - Provide Sentiment Analysis Model
 - Utilize Amazon Web Services
 - Endpoint Twitter Consumer Service
 - Workers to Analyze Tweets via Kinesis
 - Store Tweet Information via Redshift
 - Provide Graphical Web and Mobile Dashboards
- Technologies
 - Twitter APIs
 - Amazon Web Services (AWS)
 - Kinesis Client Library
 - Redshift Cloud Data Storage
 - Web and Mobile User Interfaces



amazon

Seattle, Washington



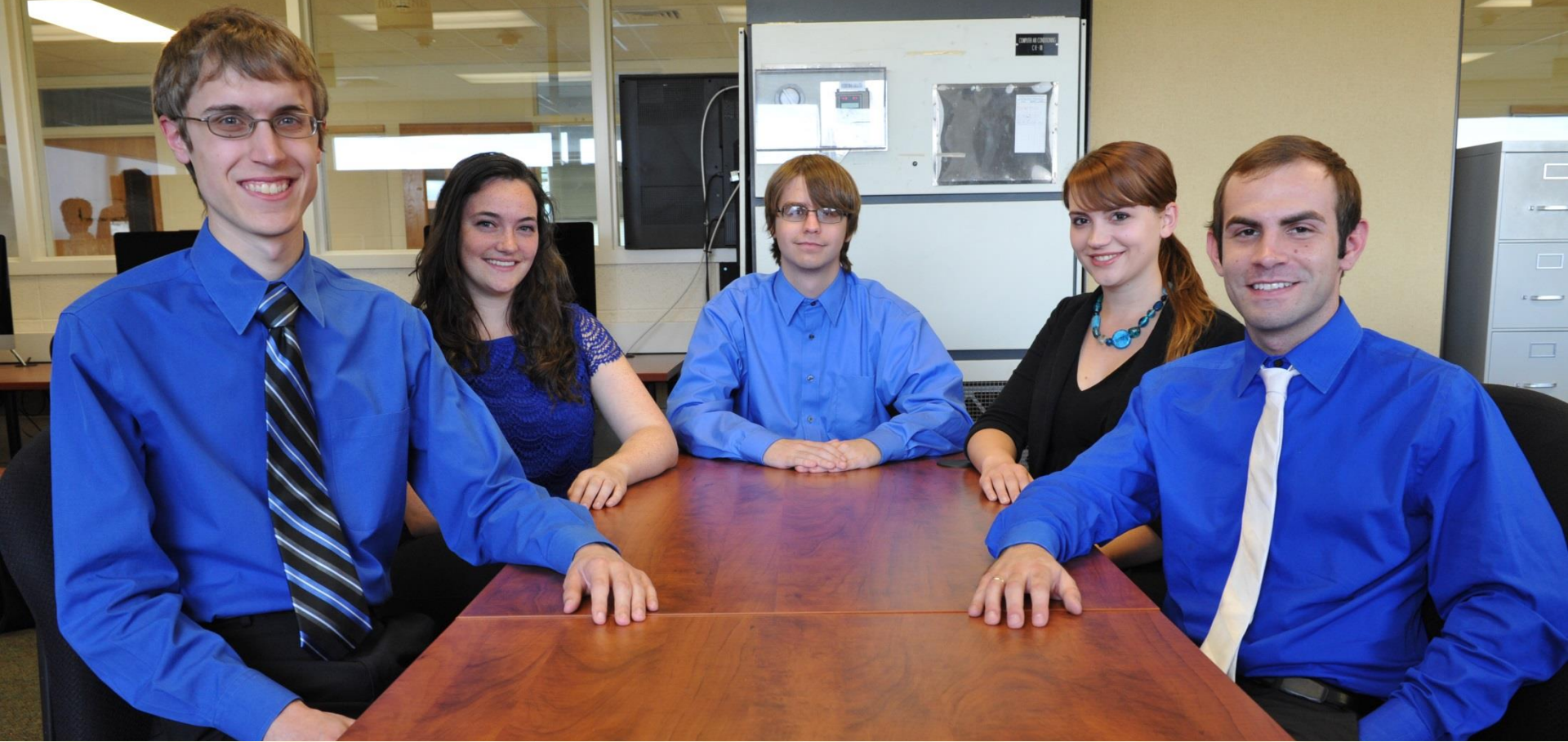

Team Amazon

Paul Stanos, Caitlin McDonald, Michael Chouinard, Erin Hoffman, Justin Vrooman

Team Amazon Project Plan Presentation

Screen Mockup

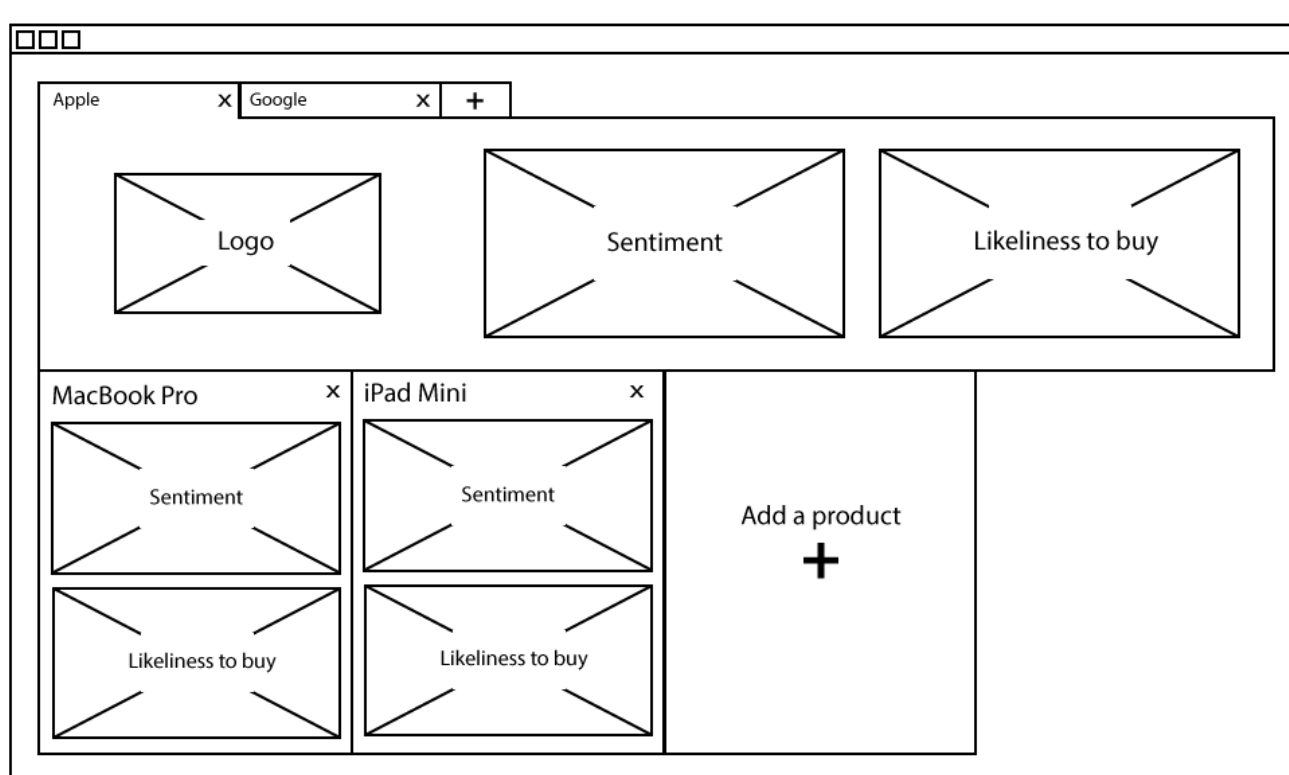



Team Amazon Project Plan Presentation

Team Amazon Project Plan Presentation

Architecture Diagram

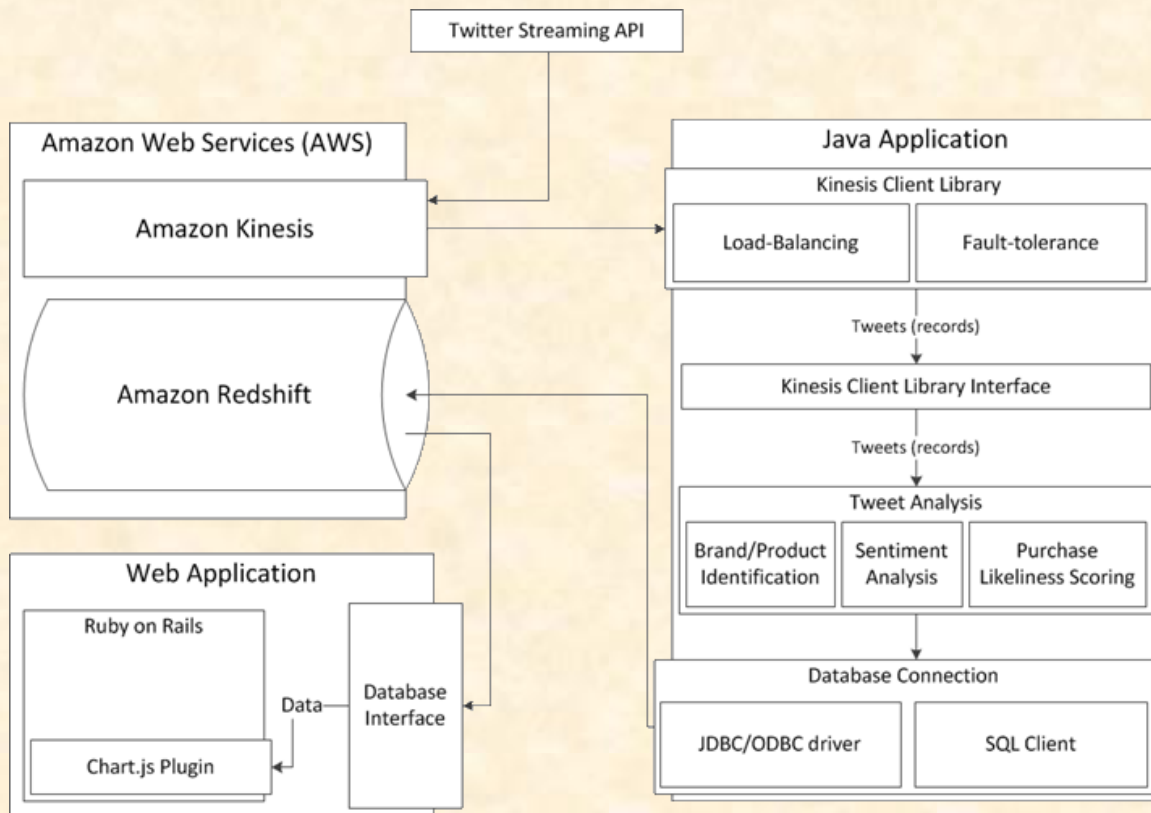



System Architecture

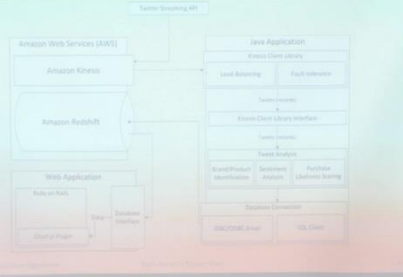

Team Amazon
Project Plan Presentation

Team Amazon Project Plan Presentation

Screen Mockups

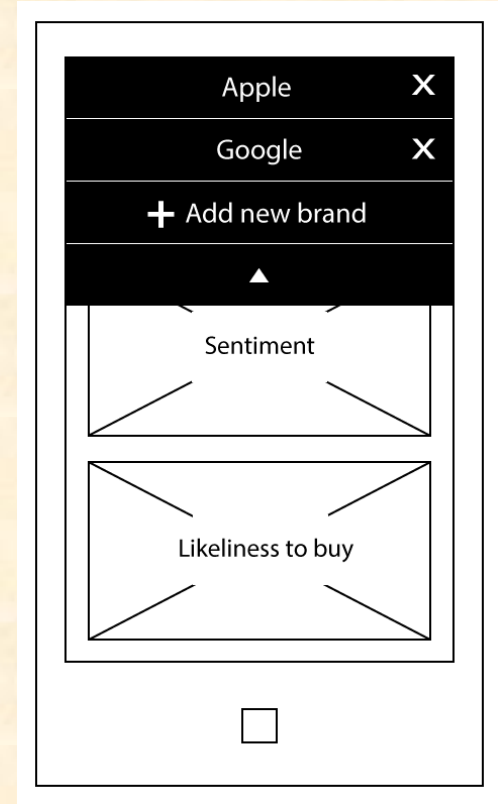
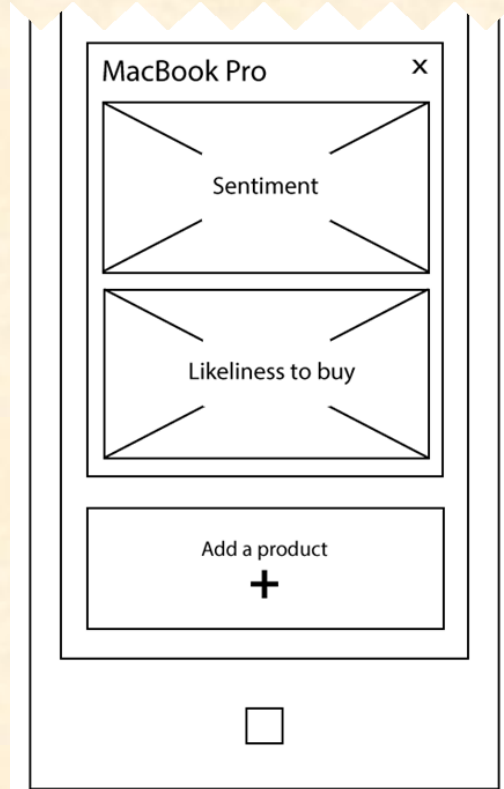
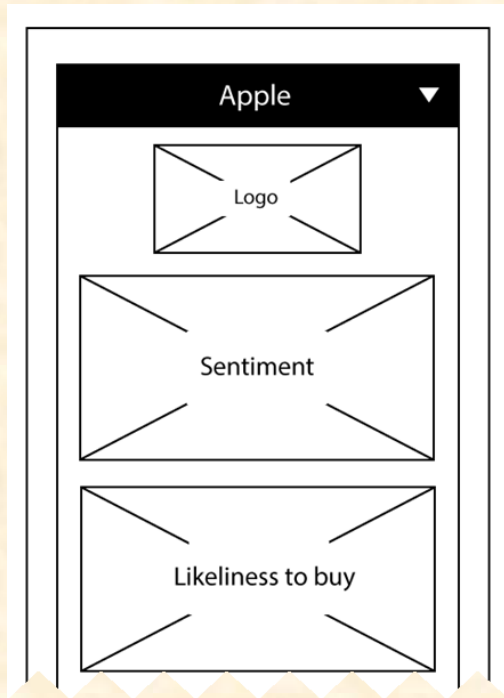



Team Amazon Alpha Presentation

Team Amazon Alpha Presentation

Sentiment Scoring

Enter a Tweet: my new #iphone is very awesome. I can't believe how cool it is!!!

Calculate Sentiment

| | | |
|---------|--------------------|--|
| my | | |
| new | | |
| iphone | Product : apple | Total Sentiment: 1.5833333333333333 |
| is | | |
| very | Adverb : *2 | |
| awesome | 1.3333333333333333 | Likely to buy : Yes |
| i | | |
| can't | Negation : *-1 | |
| believe | | |
| how | | |
| cool | 0.25 | |
| it | | |
| is | | |
| | | |
| | | |
| | | |
| | | |
| | | |
| | | |
| | | |
| | | |
| | | |
| | | |
| | | |
| | | |
| | | |



Team Amazon Alpha Presentation

Twitter Tweets Statistics



System Architecture

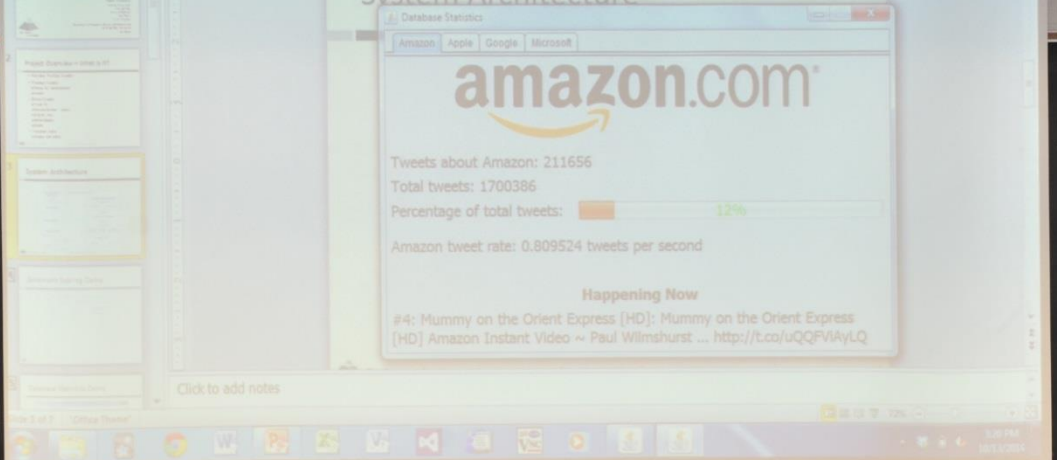

Team Amazon
Alpha Presentation

Team Amazon Alpha Presentation

Desktop Front-End

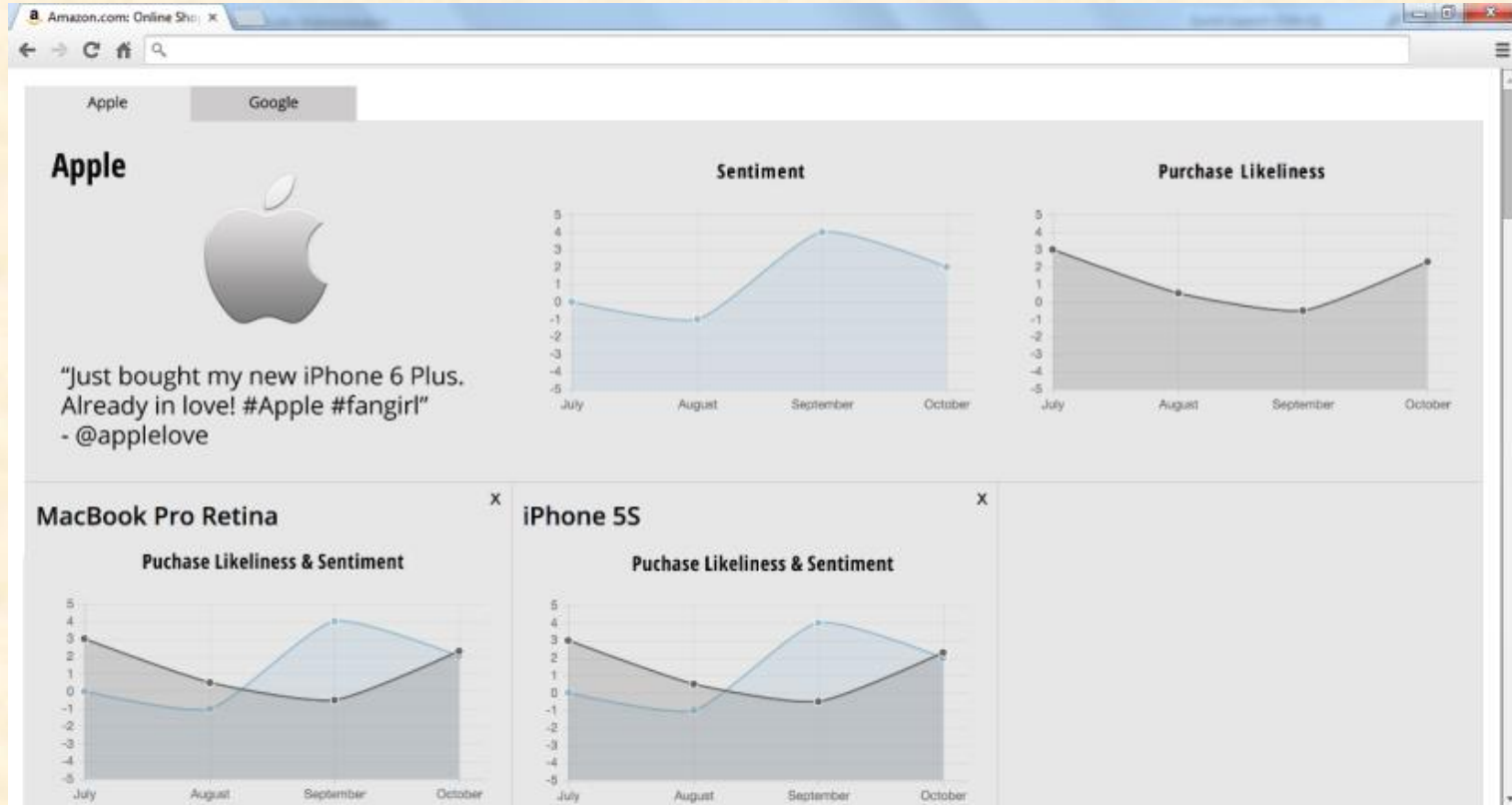



Team Amazon Beta Presentation

Team Amazon Beta Presentation

Back-End Statistics

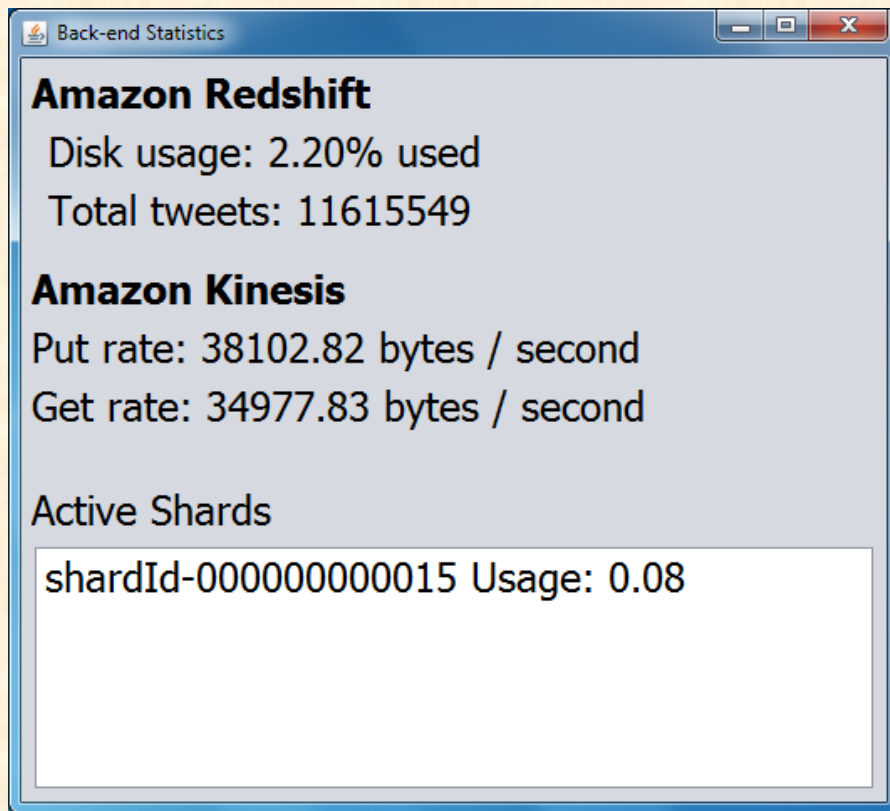

A screenshot of a window titled "Back-end Statistics" with standard Windows window controls (minimize, maximize, close). The window content is as follows:

Amazon Redshift
Disk usage: 2.20% used
Total tweets: 11615549

Amazon Kinesis
Put rate: 38102.82 bytes / second
Get rate: 34977.83 bytes / second

Active Shards

```
shardId-000000000015 Usage: 0.08
```



Team Amazon Beta Presentation

Web App

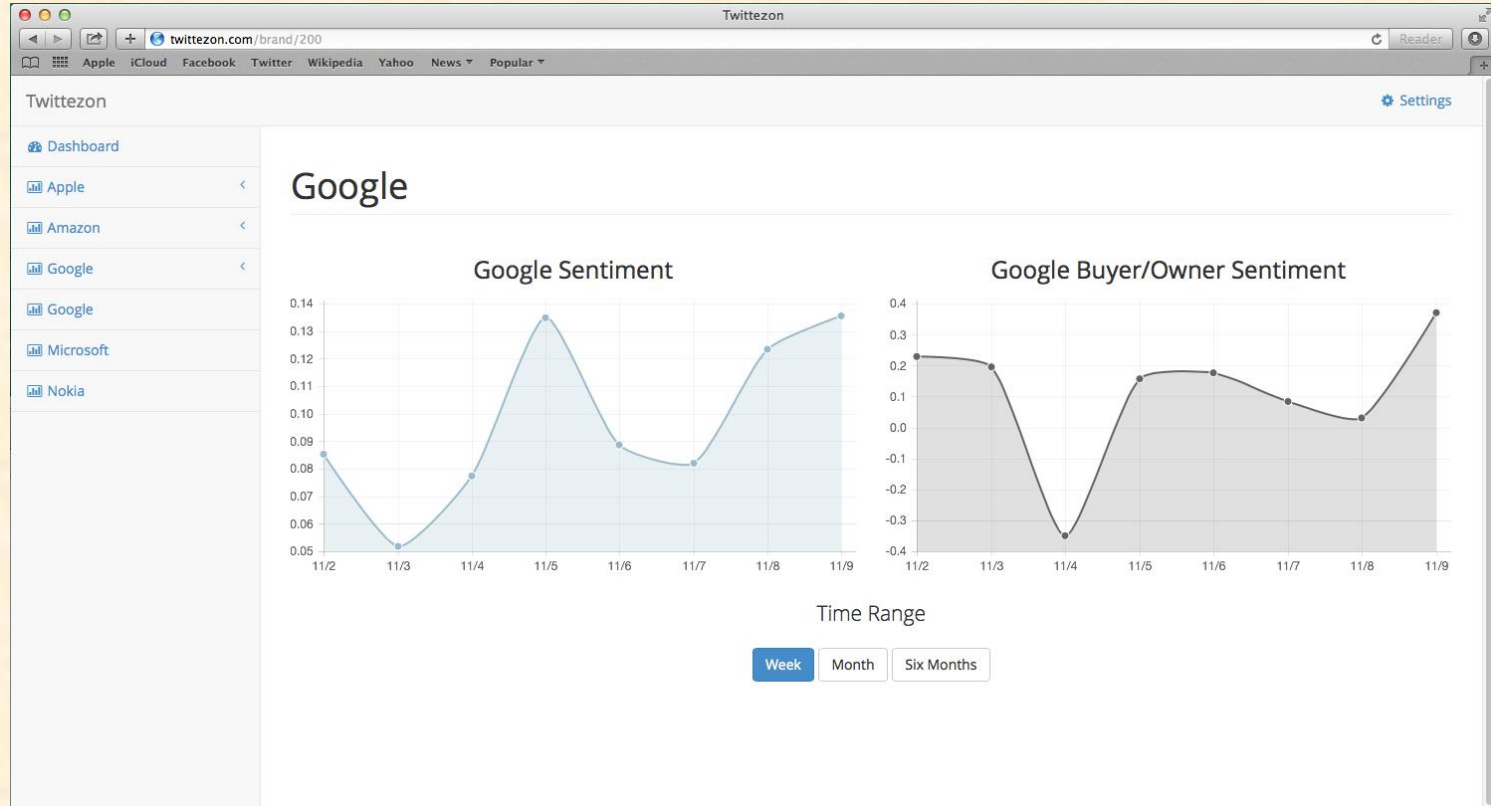



Team Amazon Beta Presentation

Team Amazon Beta Presentation

Mobile App

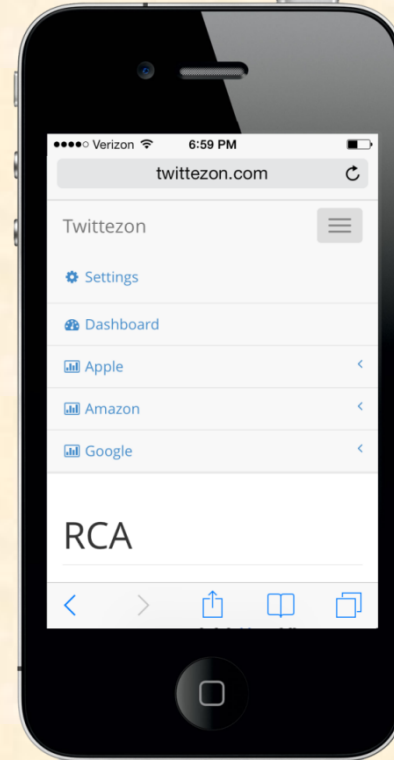
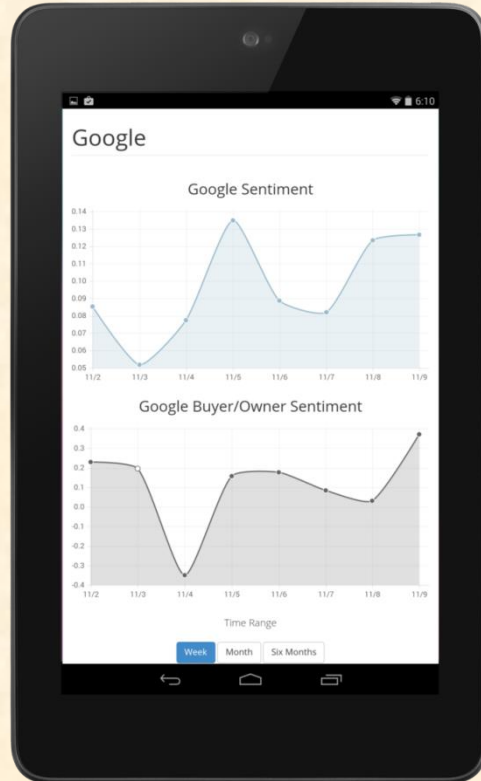

The Capstone Experience





Team Amazon
Design Day

MICHIGAN STATE
UNIVERSITY

The Capstone Experience

Team Auto-Owners

Department of Computer Science and Engineering
Michigan State University

Fall 2014



*From Students...
...to Professionals*



Auto-Owners Insurance

Life Home Car Business

The "No Problem" People[®]

Auto-Owners Insurance

OUR PRODUCTS

CORPORATE INFORMATION

CUSTOMER CLAIMS

Enter a Keyword

Find

Find a Local Agency

Enter a Zip Code

Find

or Search by Address



Quality Coverage in 26 States

Start an Auto Quote

Customer Log In



Learn more >

Drivers usually spend five seconds looking at their phones, which is enough time to cover more than the length of a football field going normal highway speeds.

Life Insurance

Protecting your family

Home Insurance

Property and liability

Car Insurance

Security while on the road

Business Insurance

Guarding your investment

Team Auto-Owners Project Overview

Navigation Assistant and Accident History App

- Functionalities
 - Provide Safest Navigation Routing for Drivers
 - Analyze Driving Risk Patterns to Calculate Insurance Rates
 - Based on Historical Accident Data
- Features
 - Utilize Delays Based on Prior Driving Routes and Times
 - Send Text or Email Notifications for Alternate Routes
 - Synchronize with Owner's Car via Bluetooth
 - Provide Web App for Auto-Owners Administrators
- Technologies
 - Apple (iOS) iPhone and iPad
 - Objective-C
 - Google Android
 - Java



Lansing, Michigan





Team Auto-Owners

Isaac Vogler, Zach Ray, Tim Sloncz, Megan Frankel, Austin Huynh

Team Auto-Owners Project Plan Presentation

Screen Mockups

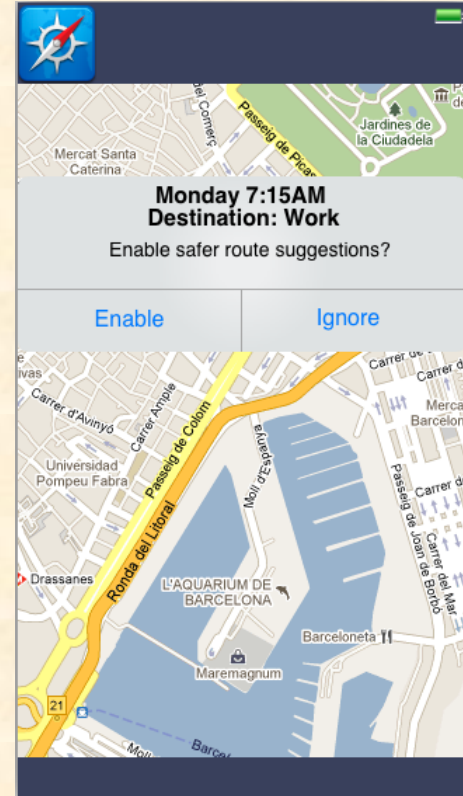



Team Auto-Owners Project Plan Presentation

Team Auto-Owners Project Plan Presentation

Architecture Diagram

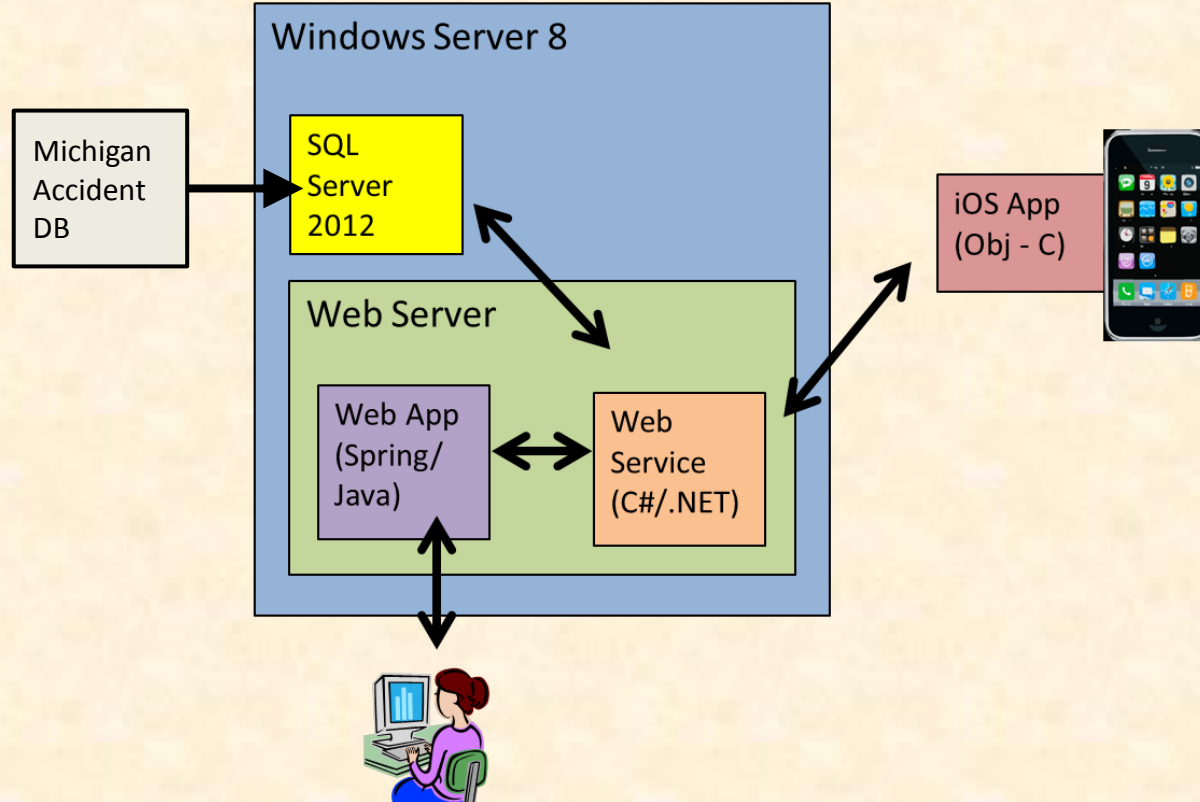

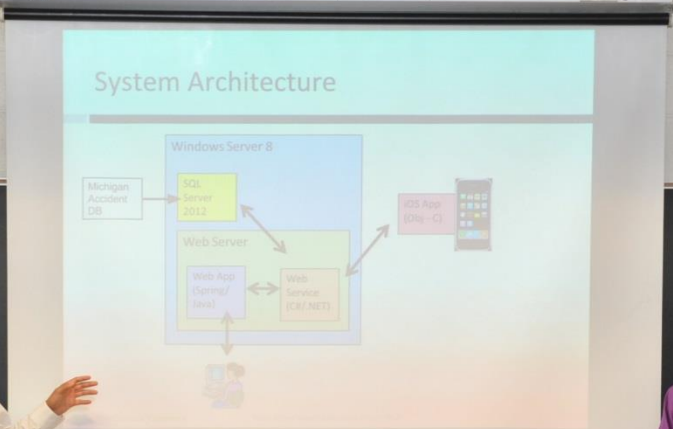
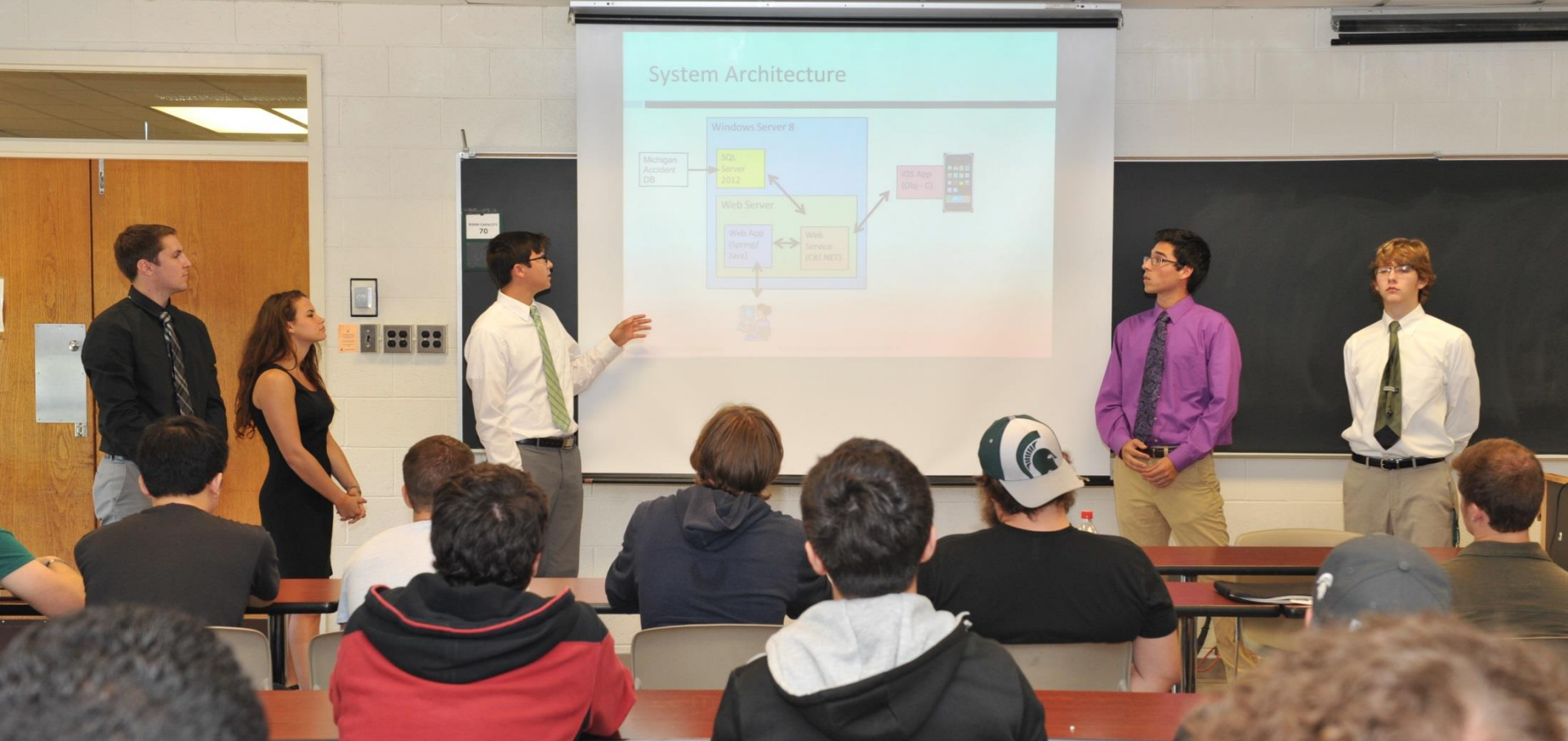

Team Auto-Owners
Project Plan Presentation

Team Auto-Owners Project Plan Presentation

Screen Mockup





Team Auto-Owners Alpha Presentation

Team Auto-Owners Alpha Presentation

Android App

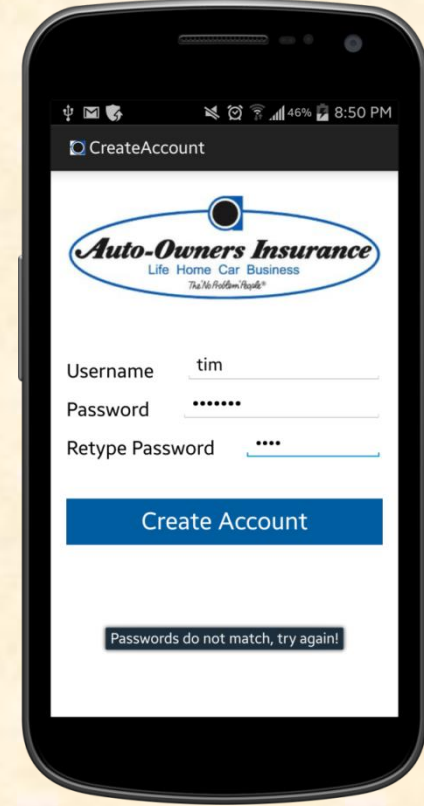
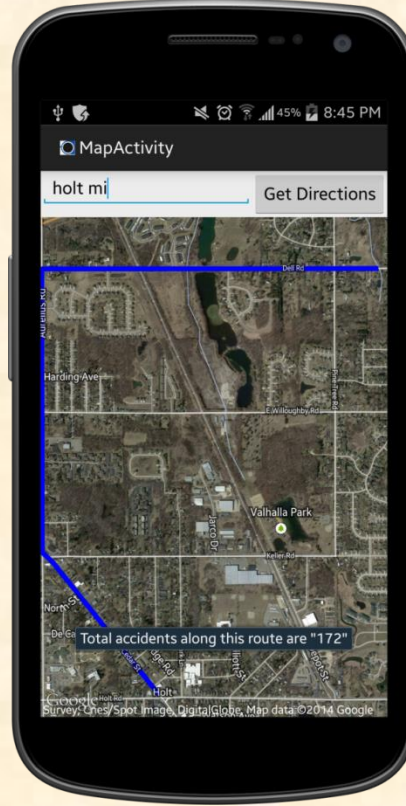
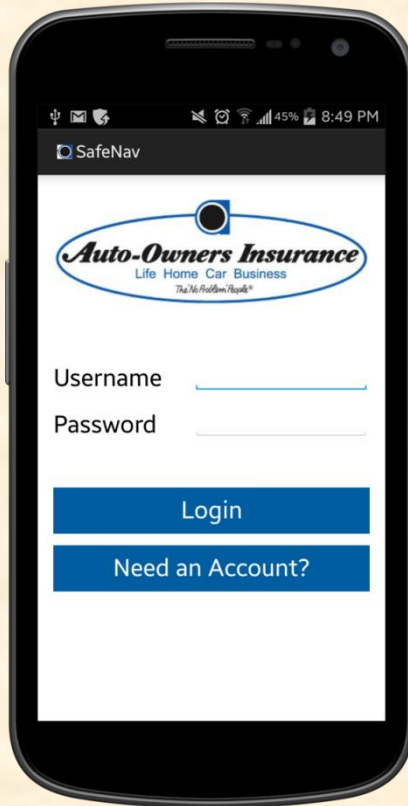

The Capstone Experience



Team Auto-Owners Alpha Presentation

iPhone App

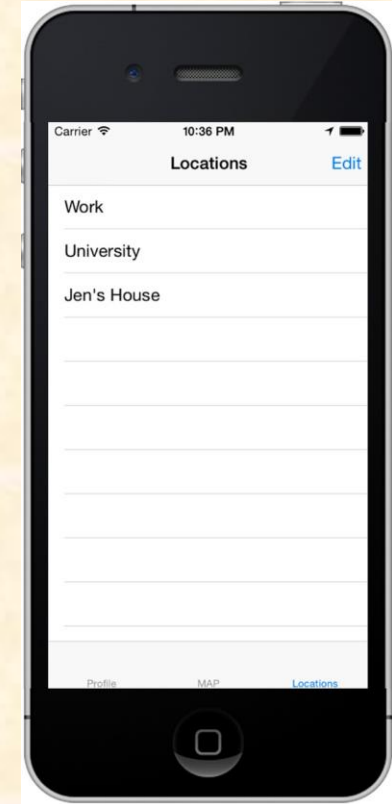
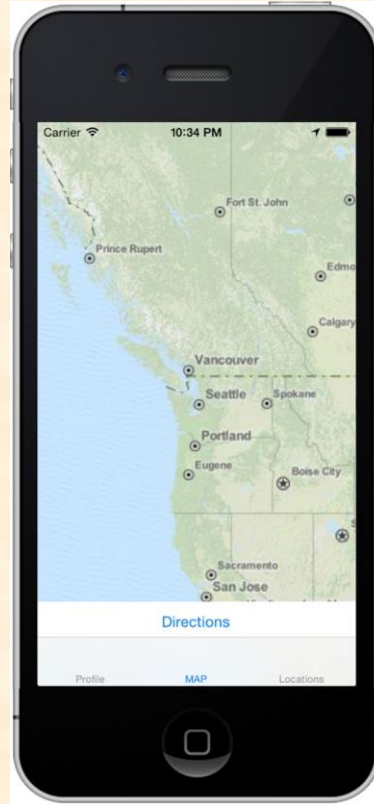
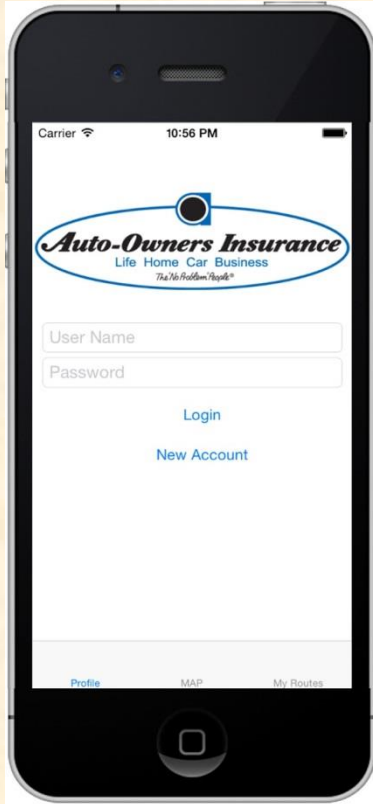



Team Auto-Owners
Alpha Presentation

Team Auto-Owners Alpha Presentation

Web App

The screenshot shows a web browser window with the URL `localhost:8080/SafeNav/userPage`. The page features a blue header with the text "Auto-Owners Insurance" and "Welcome tim.". Below the header, there are three main sections: "New Features", "Profile", and "Acceleration & Braking". Each section has a "View details" button. The "New Features" section includes a "Try it" button. The "Profile" section has a "View details" button. The "Acceleration & Braking" section has a "View details" button. The main content area is dominated by a map of Lansing, Michigan, with several red location pins placed across the city. The map includes labels for various landmarks such as "International airport", "Eastwood Towne Center", "Lansing Charter Twp", "East Lansing", "Michigan State University", and "Forest Akers East Golf Course".





Team Auto-Owners Beta Presentation

Team Auto-Owners Beta Presentation

Android App

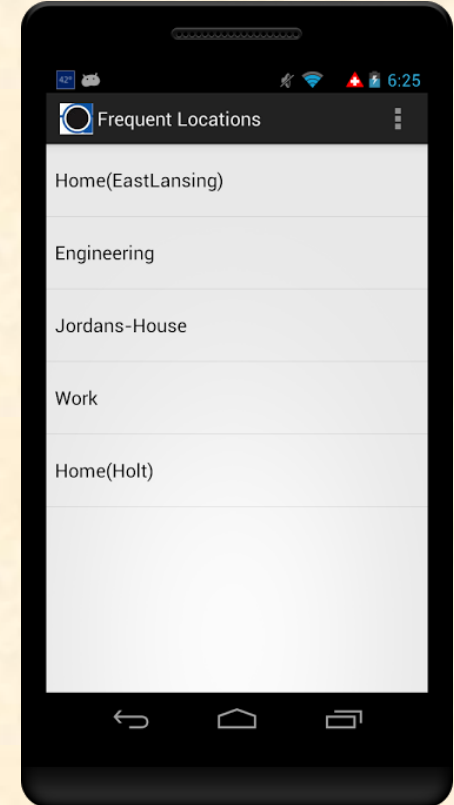
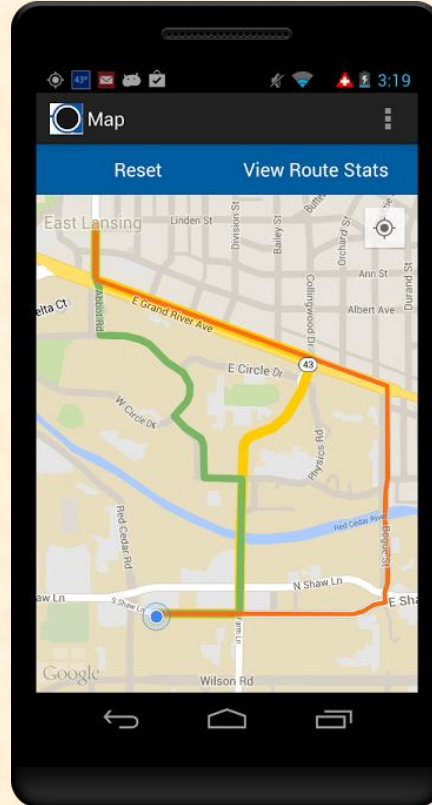
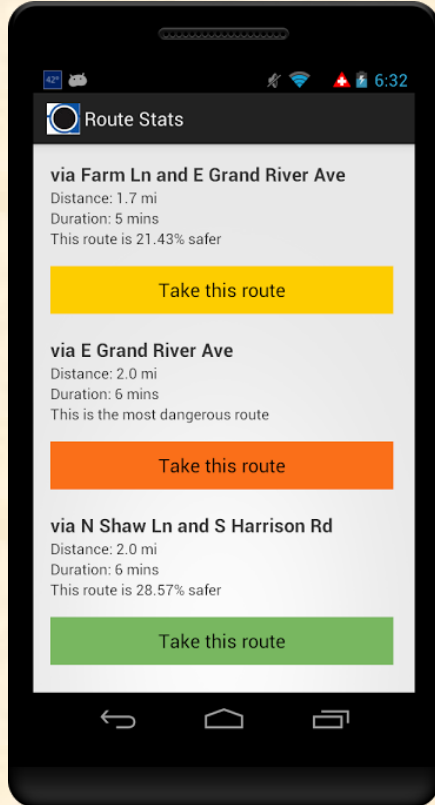

The Capstone Experience



Team Auto-Owners Beta Presentation

iPhone App

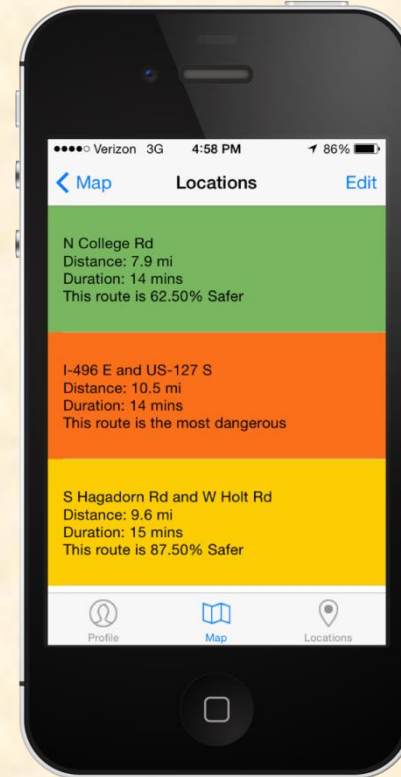
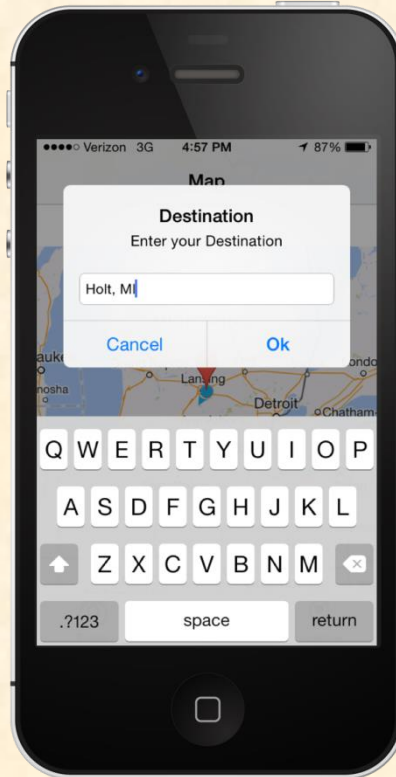
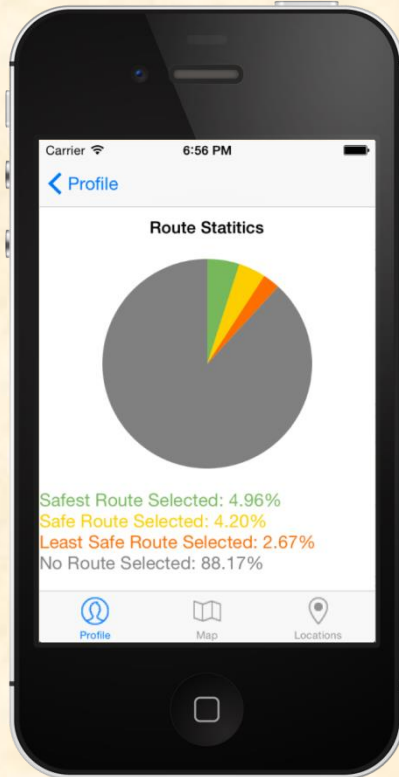



Team Auto-Owners
Beta Presentation

Team Auto-Owners Beta Presentation

Web App

The screenshot shows a web browser window displaying a 'Locations' management page. The page has a blue header with the title 'Locations'. Below the header, there is a search bar with the text 'Engineering' entered. A table lists the schedule for this location, with columns for 'Day', 'Arrive', 'Depart', and 'Delete'. Each row represents a day of the week with its corresponding arrival and departure times and a red 'Delete' button. An 'Update' button is located below the table. At the bottom of the page, there is a map showing the location of the location in the Lansing, Michigan area, with a red pin marking the location.

| Day | Arrive | Depart | Delete |
|-----------|----------|---------|--------|
| Monday | 10:57:AM | 9:51:PM | Delete |
| Wednesday | 10:15:AM | 3:54:PM | Delete |
| Thursday | 5:23:PM | 9:57:PM | Delete |
| Friday | 3:21:PM | 7:32:PM | Delete |
| Sunday | 3:40:PM | 9:10:PM | Delete |
| Monday | 7:14:PM | 7:47:PM | Delete |
| Tuesday | 4:18:PM | 7:21:PM | Delete |



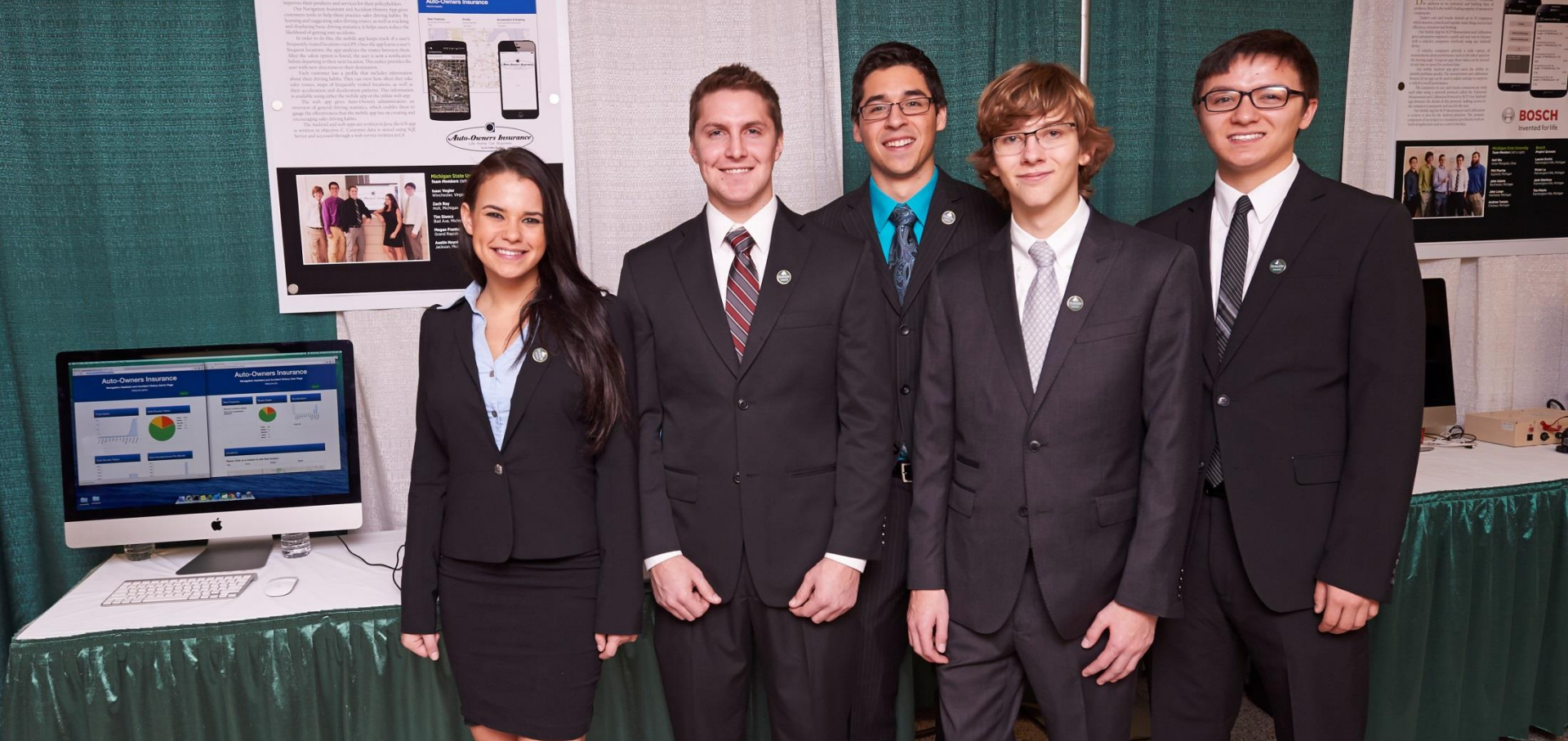

Team Auto-Owners
Design Day

MICHIGAN STATE

UNIVERSITY

The Capstone Experience

Team Bosch

Department of Computer Science and Engineering
Michigan State University
Fall 2014



*From Students...
...to Professionals*



BOSCH

Invented for life

Bosch in the USA



Bosch World Experience 2014 Around the world in 16 days

Six destinations, three continents, one unforgettable adventure. From the famous Tower Bridge in London to automated driving in San Francisco – Bosch technology is in places you may never have thought! Witness the diversity of Bosch's innovative and beneficial solutions around the world with this exclusive chance to look behind the scenes!

[Join the experience](#)[Mobility](#)[At Home](#)[Industry and Trade](#)[Healthcare](#)[Corporate Information](#)[> Bosch Car Service](#)[> About Bosch in the USA](#)

Team Bosch

Project Overview

Mobile App for XCP Measurement and Calibration

- Functionalities
 - Enable Measurement and Calibration
 - Of Automobile Electronic Stability Control ECU
 - Via Android App
 - Using Vehicle Application Mobile Platform (VAMP)
- Features
 - Support Android Tablets
 - Communicate Wirelessly Via Bluetooth
 - Interface with BlueCAN Dongle
- Technologies
 - Google Android App Development
 - Java
 - Controller Area Network (CAN)
 - Universal Measurement and Calibration Protocol (XCP)
 - Vehicle Application Mobile Platform (VAMP)
 - Bluetooth

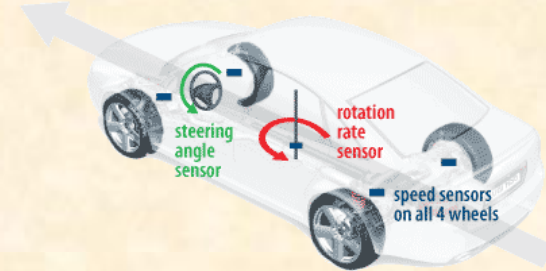

BOSCH

Invented for life

Farmington Hills, Michigan

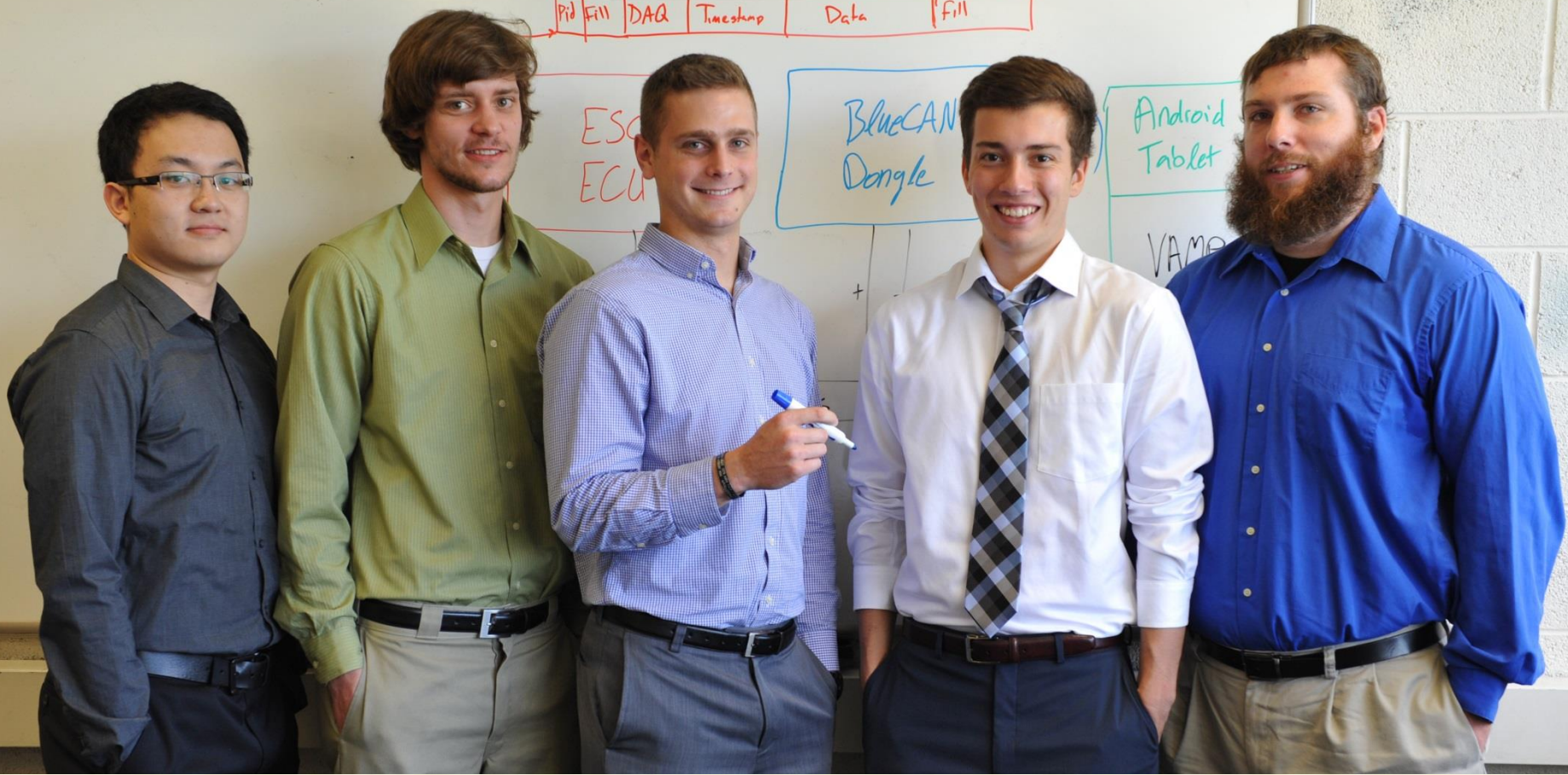

Team Bosch

Neil Wu, Phil Plachta, John Adams, Jake Lange, Andrew Tomaka

Team Bosch Project Plan Presentation

Screen Mockup

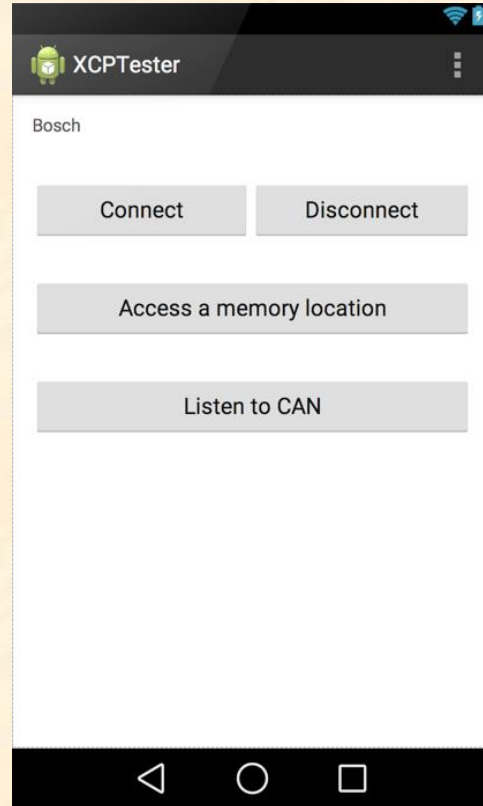



Team Bosch Project Plan Presentation

Team Bosch Project Plan Presentation

Architecture Diagram

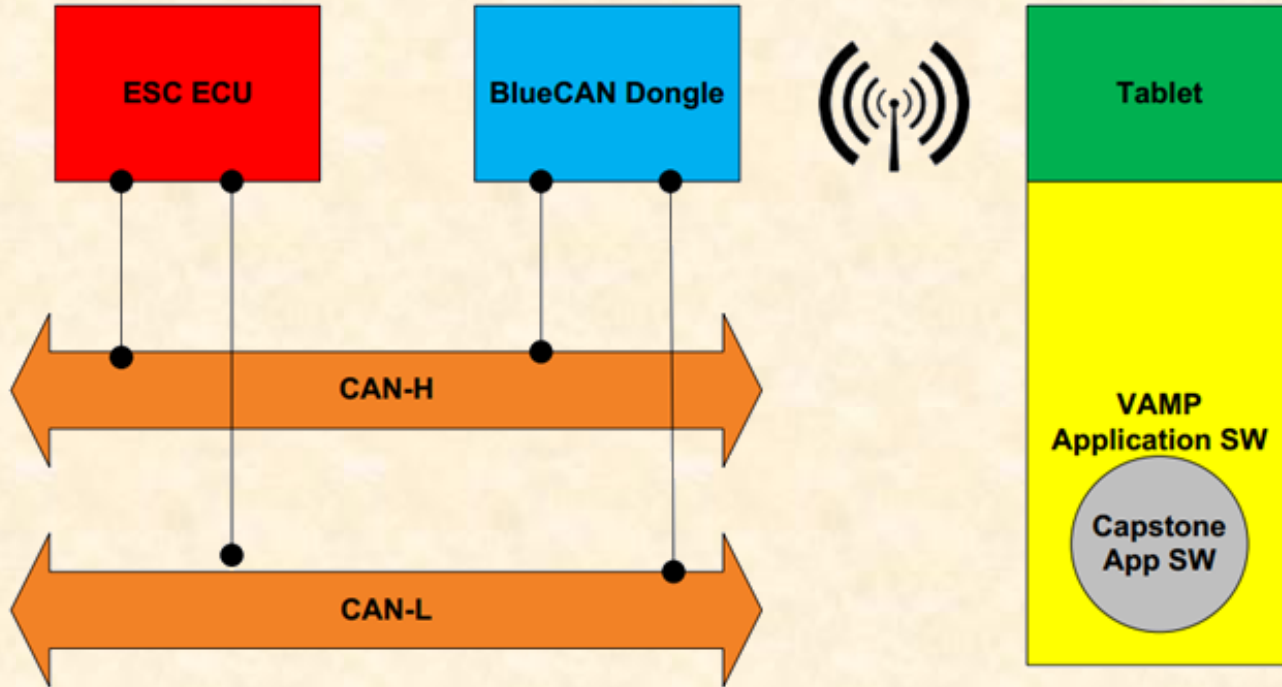



System Architecture

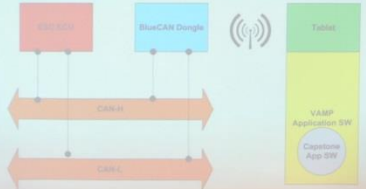

Team Bosch
Project Plan Presentation

Team Bosch Project Plan Presentation

Screen Mockups

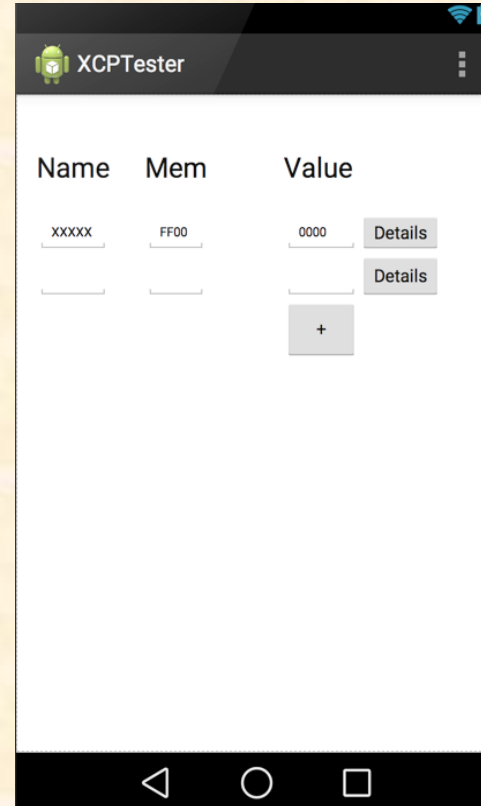
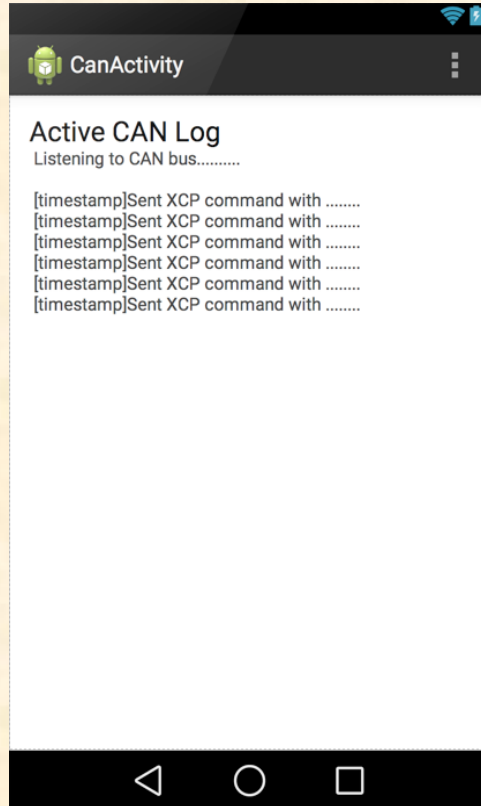



Team Bosch
Alpha Presentation

Team Bosch Alpha Presentation

Hardware

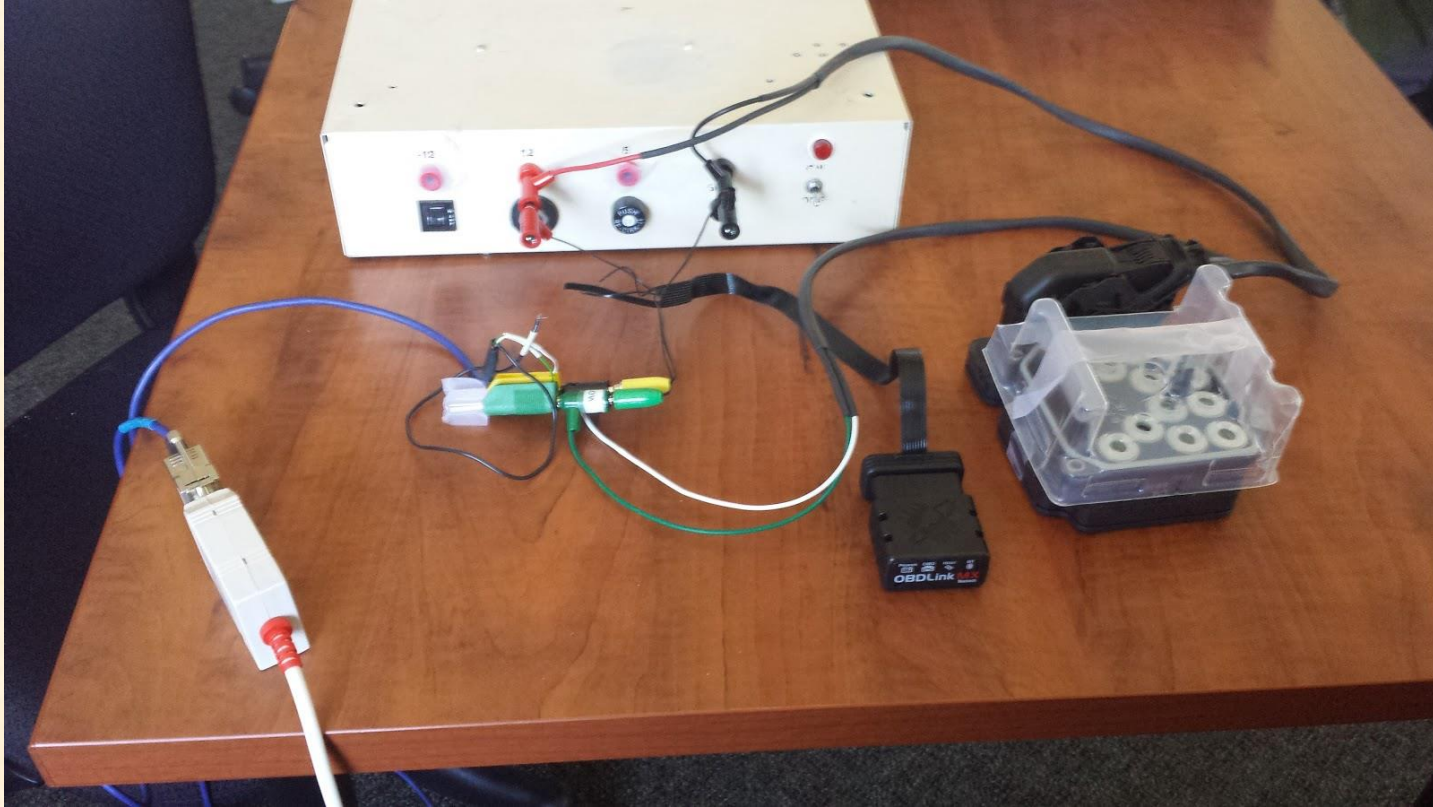

The Capstone Experience



Team Bosch Alpha Presentation

Initial Launch

The image displays two software interfaces side-by-side. On the left is the BUSMASTER application, a PC-based CAN bus diagnostic tool. It features a menu bar (File, CAN, J1939, FloRay, LIN, View, Window, Help) and a toolbar with various icons for file operations, CAN control, and data visualization. A central table is used for displaying CAN messages, with columns for Time, Tx/Rx, Channel, Msg, ID, Message, DLC, and Data Bytes. On the right is the XCPonCAN Android application, shown within an Android Screen Monitor. The app's header includes the XCPonCAN logo and the time 10:48. The main interface consists of five large, light-gray buttons: 'Connect', 'Send XCP CONNECT', 'Send XCP GET_STATUS', 'Off', and a 'Closed' button at the bottom. The status bar at the bottom of the Android screen shows system icons for connectivity and battery.

Team Bosch Alpha Presentation

Send XCP CONNECT

The image shows two side-by-side screenshots. The left screenshot is of the BUSMASTER software interface, titled 'BUSMASTER - [Message Window - CAN]'. It features a menu bar (File, CAN, J1939, FlexRay, LIN, View, Window, Help) and a toolbar with various icons. Below the toolbar is a table with columns: Time, Tx/Rx, Channel, Msg, ID, Message, DLC, and Data Byte(s). The table contains two rows of data:

| Time | Tx/Rx | Channel | Msg | ID | Message | DLC | Data Byte(s) |
|---------------|-------|---------|-----|-------|---------|-----|----------------|
| 22:50:10.4750 | Rx | 1 | * | 0x333 | 0x333 | 8 | FF 00 00 00... |
| 22:50:10.4820 | Rx | 1 | s | 0x777 | 0x777 | 8 | FF 05 01 08... |

The right screenshot is of an Android application titled 'XCPonCAN'. It has a black header bar with the application name and a hamburger menu icon. Below the header, there are four large grey buttons: 'Disconnect', 'Send XCP CONNECT', 'Send XCP GET_STATUS', and 'Off'. At the bottom, there is a dark grey box containing the text 'CAN message was sent'.



Team Bosch
Alpha Presentation

Team Bosch Alpha Presentation

Send XCP GET_STATUS

The image shows two software windows side-by-side. The left window is 'BUSMASTER - [Message Window - CAN]' and the right is 'Android Screen Monitor'.

BUSMASTER - [Message Window - CAN]

| Time | Dir/Tx | Channel | Msg | ID | Message | DBC | Data Bytes |
|---------------|--------|---------|-----|-------|---------|-----|-----------------|
| 22:50:30.0708 | Rx | 1 | * | 0x333 | 0x333 | 8 | FE 00 00 00 ... |
| 22:50:30.0893 | Rx | 1 | o | 0x777 | 0x777 | 1 | FF |

Android Screen Monitor

XCPonCAN

Buttons:

- Disconnect
- Send XCP CONNECT
- Send XCP GET_STATUS
- Off

Message box: CAN message was sent

Bottom status bar: Config File: CAN Recording J1939 Recording... 1 Channel(s) - PEAK USB -!



Team Bosch
Beta Presentation

Team Bosch Beta Presentation

Connect

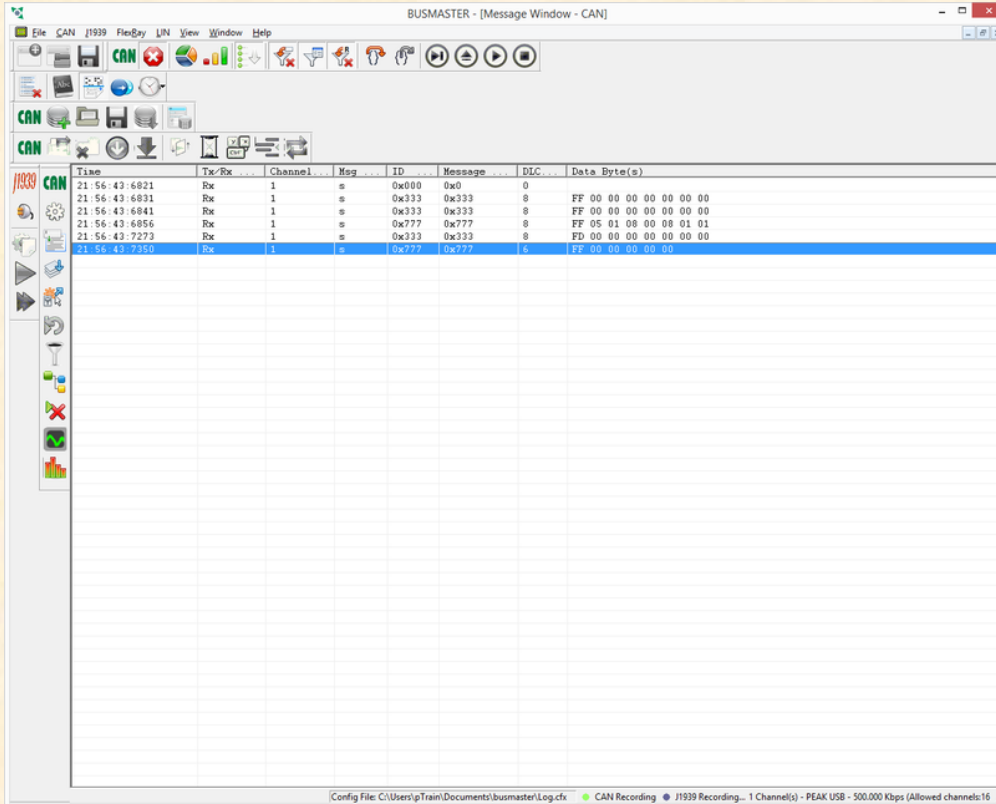

The screenshot shows the BUSMASTER software interface with a message log table. The table has columns for Time, Tx/Rx, Channel, Msg, ID, Message, DLC, and Data Byte(s). The log shows several received messages (Rr) with IDs 0x000, 0x333, and 0x777. The most recent message at 21:56:43.7350 is highlighted in blue.

| Time | Tx/Rx | Channel | Msg | ID | Message | DLC | Data Byte(s) |
|---------------|-------|---------|-----|-------|---------|-----|-------------------------|
| 21:56:43.6821 | Rr | 1 | s | 0x000 | 0x0 | 0 | |
| 21:56:43.6831 | Rr | 1 | s | 0x333 | 0x333 | 8 | FF 00 00 00 00 00 00 00 |
| 21:56:43.6841 | Rr | 1 | s | 0x333 | 0x333 | 8 | FF 00 00 00 00 00 00 00 |
| 21:56:43.6856 | Rr | 1 | s | 0x777 | 0x777 | 8 | FF 05 01 00 00 00 01 01 |
| 21:56:43.7223 | Rr | 1 | s | 0x333 | 0x333 | 8 | FD 00 00 00 00 00 00 00 |
| 21:56:43.7350 | Rr | 1 | s | 0x777 | 0x777 | 6 | FF 00 00 00 00 00 |

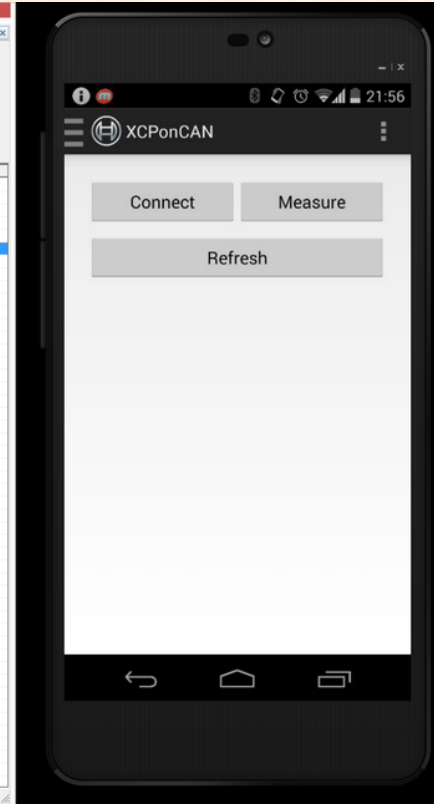

Team Bosch Beta Presentation

Measure

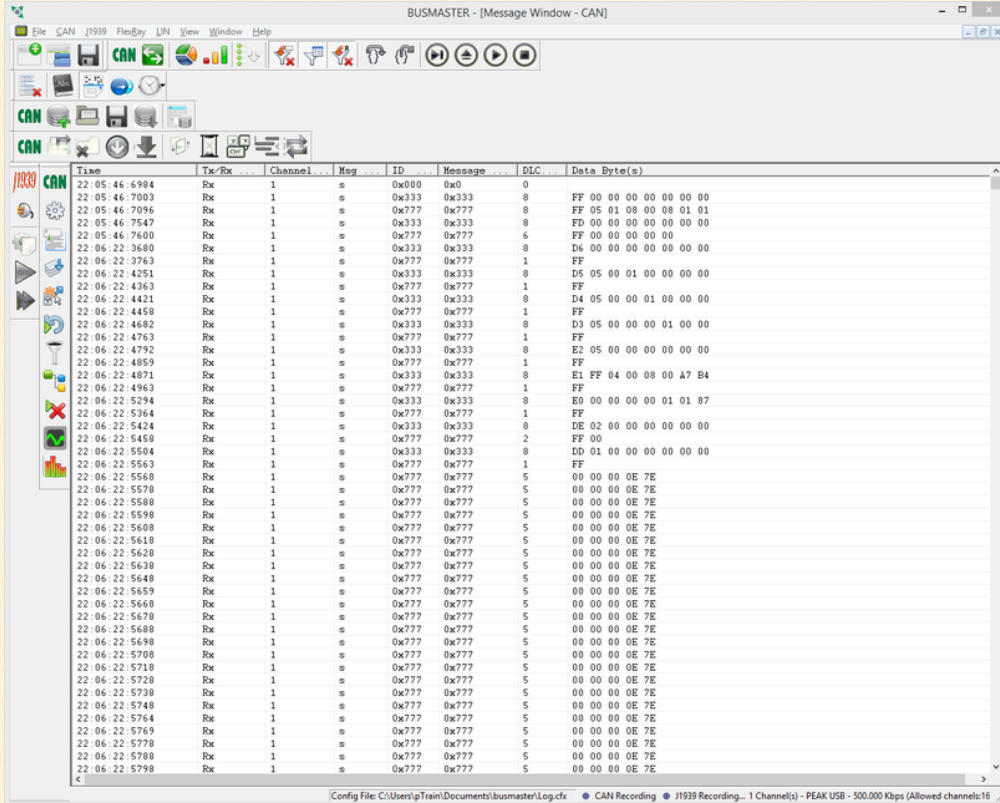

The screenshot shows the BUSMASTER software interface with a message log table. The table columns are Time, Tx/Rx, Channel, Msg, ID, Message, DLC, and Data Byte(s). The log contains 38 entries, all received (Rxx) on channel 1, with IDs 0x000, 0x333, and 0x777. The data bytes vary, including sequences of FF, D5, D4, D3, E2, E1, E0, DE, FF, and ID.

| Time | Tx/Rx | Channel | Msg | ID | Message | DLC | Data Byte(s) |
|---------------|-------|---------|-----|-------|---------|-----|----------------------------|
| 22:05:46:6984 | Rxx | 1 | s | 0x000 | 0x0 | 0 | |
| 22:05:46:7003 | Rxx | 1 | s | 0x333 | 0x333 | 8 | FF 00 00 00 00 00 00 00 |
| 22:05:46:7096 | Rxx | 1 | s | 0x777 | 0x777 | 8 | FF 05 01 08 00 08 01 01 |
| 22:05:46:7547 | Rxx | 1 | s | 0x333 | 0x333 | 8 | FF 00 00 00 00 00 00 00 |
| 22:05:46:7600 | Rxx | 1 | s | 0x777 | 0x777 | 4 | FF 00 00 00 00 |
| 22:06:22:3680 | Rxx | 1 | s | 0x333 | 0x333 | 8 | D6 00 00 00 00 00 00 00 |
| 22:06:22:3763 | Rxx | 1 | s | 0x777 | 0x777 | 1 | FF |
| 22:06:22:4251 | Rxx | 1 | s | 0x333 | 0x333 | 8 | D5 05 00 01 00 00 00 00 |
| 22:06:22:4363 | Rxx | 1 | s | 0x777 | 0x777 | 1 | FF |
| 22:06:22:4421 | Rxx | 1 | s | 0x333 | 0x333 | 8 | D4 05 00 00 01 00 00 00 |
| 22:06:22:4458 | Rxx | 1 | s | 0x777 | 0x777 | 1 | FF |
| 22:06:22:4682 | Rxx | 1 | s | 0x333 | 0x333 | 8 | D3 05 00 00 00 01 00 00 |
| 22:06:22:4763 | Rxx | 1 | s | 0x777 | 0x777 | 1 | FF |
| 22:06:22:4792 | Rxx | 1 | s | 0x333 | 0x333 | 8 | E2 05 00 00 00 00 00 00 |
| 22:06:22:4859 | Rxx | 1 | s | 0x777 | 0x777 | 1 | FF |
| 22:06:22:4871 | Rxx | 1 | s | 0x333 | 0x333 | 8 | E1 FF 04 00 08 00 A7 B4 |
| 22:06:22:4963 | Rxx | 1 | s | 0x777 | 0x777 | 1 | FF |
| 22:06:22:5294 | Rxx | 1 | s | 0x333 | 0x333 | 8 | E0 00 00 00 00 01 01 87 |
| 22:06:22:5364 | Rxx | 1 | s | 0x777 | 0x777 | 1 | FF |
| 22:06:22:5424 | Rxx | 1 | s | 0x333 | 0x333 | 8 | DE 02 00 00 00 00 00 00 |
| 22:06:22:5458 | Rxx | 1 | s | 0x777 | 0x777 | 2 | FF 00 |
| 22:06:22:5504 | Rxx | 1 | s | 0x333 | 0x333 | 8 | ID 01 00 00 00 00 00 00 00 |
| 22:06:22:5563 | Rxx | 1 | s | 0x777 | 0x777 | 1 | FF |
| 22:06:22:5568 | Rxx | 1 | s | 0x777 | 0x777 | 5 | 00 00 00 0E 7E |
| 22:06:22:5578 | Rxx | 1 | s | 0x777 | 0x777 | 5 | 00 00 00 0E 7E |
| 22:06:22:5588 | Rxx | 1 | s | 0x777 | 0x777 | 5 | 00 00 00 0E 7E |
| 22:06:22:5598 | Rxx | 1 | s | 0x777 | 0x777 | 5 | 00 00 00 0E 7E |
| 22:06:22:5608 | Rxx | 1 | s | 0x777 | 0x777 | 5 | 00 00 00 0E 7E |
| 22:06:22:5618 | Rxx | 1 | s | 0x777 | 0x777 | 5 | 00 00 00 0E 7E |
| 22:06:22:5628 | Rxx | 1 | s | 0x777 | 0x777 | 5 | 00 00 00 0E 7E |
| 22:06:22:5638 | Rxx | 1 | s | 0x777 | 0x777 | 5 | 00 00 00 0E 7E |
| 22:06:22:5648 | Rxx | 1 | s | 0x777 | 0x777 | 5 | 00 00 00 0E 7E |
| 22:06:22:5659 | Rxx | 1 | s | 0x777 | 0x777 | 5 | 00 00 00 0E 7E |
| 22:06:22:5668 | Rxx | 1 | s | 0x777 | 0x777 | 5 | 00 00 00 0E 7E |
| 22:06:22:5678 | Rxx | 1 | s | 0x777 | 0x777 | 5 | 00 00 00 0E 7E |
| 22:06:22:5688 | Rxx | 1 | s | 0x777 | 0x777 | 5 | 00 00 00 0E 7E |
| 22:06:22:5698 | Rxx | 1 | s | 0x777 | 0x777 | 5 | 00 00 00 0E 7E |
| 22:06:22:5708 | Rxx | 1 | s | 0x777 | 0x777 | 5 | 00 00 00 0E 7E |
| 22:06:22:5718 | Rxx | 1 | s | 0x777 | 0x777 | 5 | 00 00 00 0E 7E |
| 22:06:22:5728 | Rxx | 1 | s | 0x777 | 0x777 | 5 | 00 00 00 0E 7E |
| 22:06:22:5738 | Rxx | 1 | s | 0x777 | 0x777 | 5 | 00 00 00 0E 7E |
| 22:06:22:5748 | Rxx | 1 | s | 0x777 | 0x777 | 5 | 00 00 00 0E 7E |
| 22:06:22:5764 | Rxx | 1 | s | 0x777 | 0x777 | 5 | 00 00 00 0E 7E |
| 22:06:22:5769 | Rxx | 1 | s | 0x777 | 0x777 | 5 | 00 00 00 0E 7E |
| 22:06:22:5778 | Rxx | 1 | s | 0x777 | 0x777 | 5 | 00 00 00 0E 7E |
| 22:06:22:5788 | Rxx | 1 | s | 0x777 | 0x777 | 5 | 00 00 00 0E 7E |
| 22:06:22:5798 | Rxx | 1 | s | 0x777 | 0x777 | 5 | 00 00 00 0E 7E |





Team Bosch Beta Presentation

Team Bosch Beta Presentation

Updating Value

The screenshot shows the BUSMASTER software interface with a table of received CAN messages. The table has columns for Time, Tx/Rx, Channel, Msg, ID, Message, DLC, and Data Byte(s). The messages are all received (Rr) on channel 1, with ID 0x777 and a message length (DLC) of 5. The data bytes are consistently 00 00 00 13 16.

| Time | Tx/Rx | Channel | Msg | ID | Message | DLC | Data Byte(s) |
|---------------|-------|---------|-----|-------|---------|-----|----------------|
| 22:07:09:5820 | Rr | 1 | s | 0x777 | 0x777 | 5 | 00 00 00 13 16 |
| 22:07:09:5830 | Rr | 1 | s | 0x777 | 0x777 | 5 | 00 00 00 13 16 |
| 22:07:09:5840 | Rr | 1 | s | 0x777 | 0x777 | 5 | 00 00 00 13 16 |
| 22:07:09:5850 | Rr | 1 | s | 0x777 | 0x777 | 5 | 00 00 00 13 16 |
| 22:07:09:5860 | Rr | 1 | s | 0x777 | 0x777 | 5 | 00 00 00 13 16 |
| 22:07:09:5870 | Rr | 1 | s | 0x777 | 0x777 | 5 | 00 00 00 13 16 |
| 22:07:09:5881 | Rr | 1 | s | 0x777 | 0x777 | 5 | 00 00 00 13 16 |
| 22:07:09:5890 | Rr | 1 | s | 0x777 | 0x777 | 5 | 00 00 00 13 16 |
| 22:07:09:5907 | Rr | 1 | s | 0x777 | 0x777 | 5 | 00 00 00 13 16 |
| 22:07:09:5911 | Rr | 1 | s | 0x777 | 0x777 | 5 | 00 00 00 13 16 |
| 22:07:09:5920 | Rr | 1 | s | 0x777 | 0x777 | 5 | 00 00 00 13 16 |
| 22:07:09:5930 | Rr | 1 | s | 0x777 | 0x777 | 5 | 00 00 00 13 16 |
| 22:07:09:5940 | Rr | 1 | s | 0x777 | 0x777 | 5 | 00 00 00 13 16 |
| 22:07:09:5951 | Rr | 1 | s | 0x777 | 0x777 | 5 | 00 00 00 13 16 |
| 22:07:09:5960 | Rr | 1 | s | 0x777 | 0x777 | 5 | 00 00 00 13 16 |
| 22:07:09:5971 | Rr | 1 | s | 0x777 | 0x777 | 5 | 00 00 00 13 16 |
| 22:07:09:5980 | Rr | 1 | s | 0x777 | 0x777 | 5 | 00 00 00 13 16 |
| 22:07:09:5990 | Rr | 1 | s | 0x777 | 0x777 | 5 | 00 00 00 13 16 |
| 22:07:09:6002 | Rr | 1 | s | 0x777 | 0x777 | 5 | 00 00 00 13 16 |
| 22:07:09:6010 | Rr | 1 | s | 0x777 | 0x777 | 5 | 00 00 00 13 16 |
| 22:07:09:6020 | Rr | 1 | s | 0x777 | 0x777 | 5 | 00 00 00 13 16 |
| 22:07:09:6030 | Rr | 1 | s | 0x777 | 0x777 | 5 | 00 00 00 13 16 |
| 22:07:09:6041 | Rr | 1 | s | 0x777 | 0x777 | 5 | 00 00 00 13 16 |
| 22:07:09:6050 | Rr | 1 | s | 0x777 | 0x777 | 5 | 00 00 00 13 16 |
| 22:07:09:6060 | Rr | 1 | s | 0x777 | 0x777 | 5 | 00 00 00 13 16 |
| 22:07:09:6070 | Rr | 1 | s | 0x777 | 0x777 | 5 | 00 00 00 13 16 |
| 22:07:09:6080 | Rr | 1 | s | 0x777 | 0x777 | 5 | 00 00 00 13 16 |
| 22:07:09:6090 | Rr | 1 | s | 0x777 | 0x777 | 5 | 00 00 00 13 16 |
| 22:07:09:6107 | Rr | 1 | s | 0x777 | 0x777 | 5 | 00 00 00 13 16 |
| 22:07:09:6111 | Rr | 1 | s | 0x777 | 0x777 | 5 | 00 00 00 13 16 |
| 22:07:09:6120 | Rr | 1 | s | 0x777 | 0x777 | 5 | 00 00 00 13 16 |
| 22:07:09:6130 | Rr | 1 | s | 0x777 | 0x777 | 5 | 00 00 00 13 16 |
| 22:07:09:6140 | Rr | 1 | s | 0x777 | 0x777 | 5 | 00 00 00 13 16 |
| 22:07:09:6150 | Rr | 1 | s | 0x777 | 0x777 | 5 | 00 00 00 13 16 |
| 22:07:09:6160 | Rr | 1 | s | 0x777 | 0x777 | 5 | 00 00 00 13 16 |
| 22:07:09:6170 | Rr | 1 | s | 0x777 | 0x777 | 5 | 00 00 00 13 16 |
| 22:07:09:6180 | Rr | 1 | s | 0x777 | 0x777 | 5 | 00 00 00 13 16 |
| 22:07:09:6190 | Rr | 1 | s | 0x777 | 0x777 | 5 | 00 00 00 13 16 |
| 22:07:09:6202 | Rr | 1 | s | 0x777 | 0x777 | 5 | 00 00 00 13 16 |
| 22:07:09:6210 | Rr | 1 | s | 0x777 | 0x777 | 5 | 00 00 00 13 17 |
| 22:07:09:6220 | Rr | 1 | s | 0x777 | 0x777 | 5 | 00 00 00 13 17 |
| 22:07:09:6230 | Rr | 1 | s | 0x777 | 0x777 | 5 | 00 00 00 13 17 |
| 22:07:09:6240 | Rr | 1 | s | 0x777 | 0x777 | 5 | 00 00 00 13 17 |
| 22:07:09:6250 | Rr | 1 | s | 0x777 | 0x777 | 5 | 00 00 00 13 17 |
| 22:07:09:6260 | Rr | 1 | s | 0x777 | 0x777 | 5 | 00 00 00 13 17 |
| 22:07:09:6270 | Rr | 1 | s | 0x777 | 0x777 | 5 | 00 00 00 13 17 |





Team Bosch
Design Day

MICHIGAN STATE

UNIVERSITY

The Capstone Experience

Team Ford

Department of Computer Science and Engineering
Michigan State University
Fall 2014



*From Students...
...to Professionals*





Go Further

[Cars](#)

[Crossovers & SUVs](#)

[Trucks & Vans](#)

[Shopping Tools](#)

[Owner](#)

[Find a Dealer](#)

[Saved Items](#)



MPG savvy and tech smart.



2014 **ESCAPE** [▶](#)



2015 **FUSION + HYBRID** [▶](#)



2014 **FOCUS** [▶](#)



2015 **FIESTA** [▶](#)

Team Ford Project Overview

Vehicle Audit Analytics

- Functionalities
 - Enable Ford Designers
 - To Benchmark Ford and Lincoln Products
 - Against Global Competitors
 - Via Mobile Web App
- Features
 - Target Tablet-Size Devices
 - Maintain Audit Forms Questions and Responses
 - Use Device Camera and Microphone
 - Work With and Without Internet Connection
 - Export Data and Reports
 - Encrypt Data During Storage and Transport
- Technologies
 - HTML5, CSS, JavaScript
 - AJAX (Asynchronous JavaScript and XML)
 - J2EE (Java 2 Platform Enterprise Edition)
 - Microsoft SQL Server 2012



Dearborn, Michigan



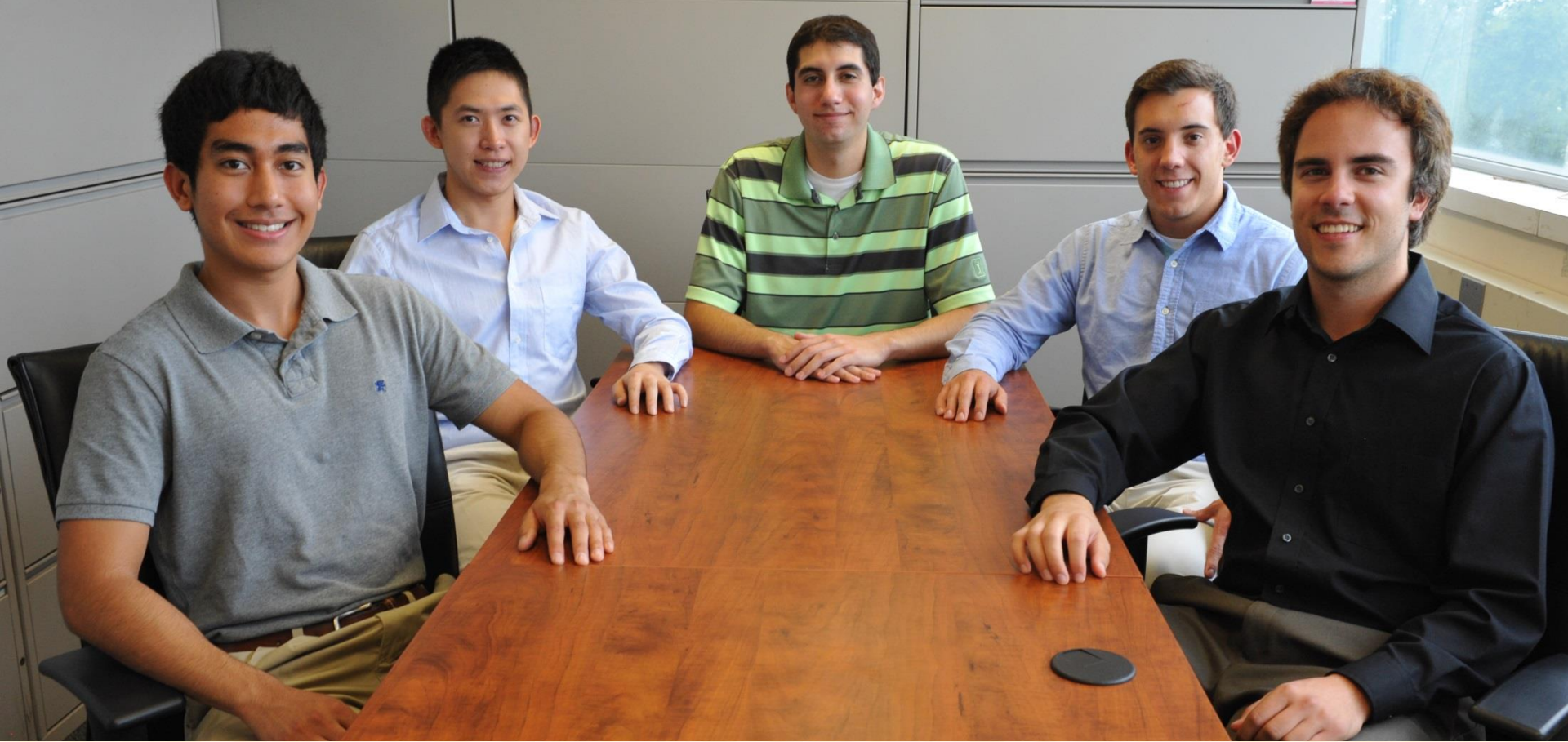

Team Ford

Aaron Torres, Peng Zhang, Zachary Madejek, Jake Prickett, Tyler Olsen

Team Ford Project Plan Presentation

Screen Mockup

 **Team Ford Project** Survey Update Upload Admin

Vehicle Information

Vehicle Year:

Vehicle Make:

Vehicle Model:

Vehicle Survey

Front console

| Feature | Rating | Media |
|----------------|---|---|
| Speedometer | <input type="text" value="Select rating: v"/> | <input type="button" value="Choose File"/> No file chosen |
| Clock | <input type="text" value="Select rating: v"/> | <input type="button" value="Choose File"/> No file chosen |
| Radio | <input type="text" value="Select rating: v"/> | <input type="button" value="Choose File"/> No file chosen |
| Dashboard | <input type="text" value="Select rating: v"/> | <input type="button" value="Choose File"/> No file chosen |
| Steering Wheel | <input type="text" value="Select rating: v"/> | <input type="button" value="Choose File"/> No file chosen |

Select rating:
1 (Low rating)
2
3
4
5 (Medium rating)
6
7
8
9
10 (Best rating)





Team Ford Project Plan Presentation

Team Ford Project Plan Presentation

Architecture Diagram

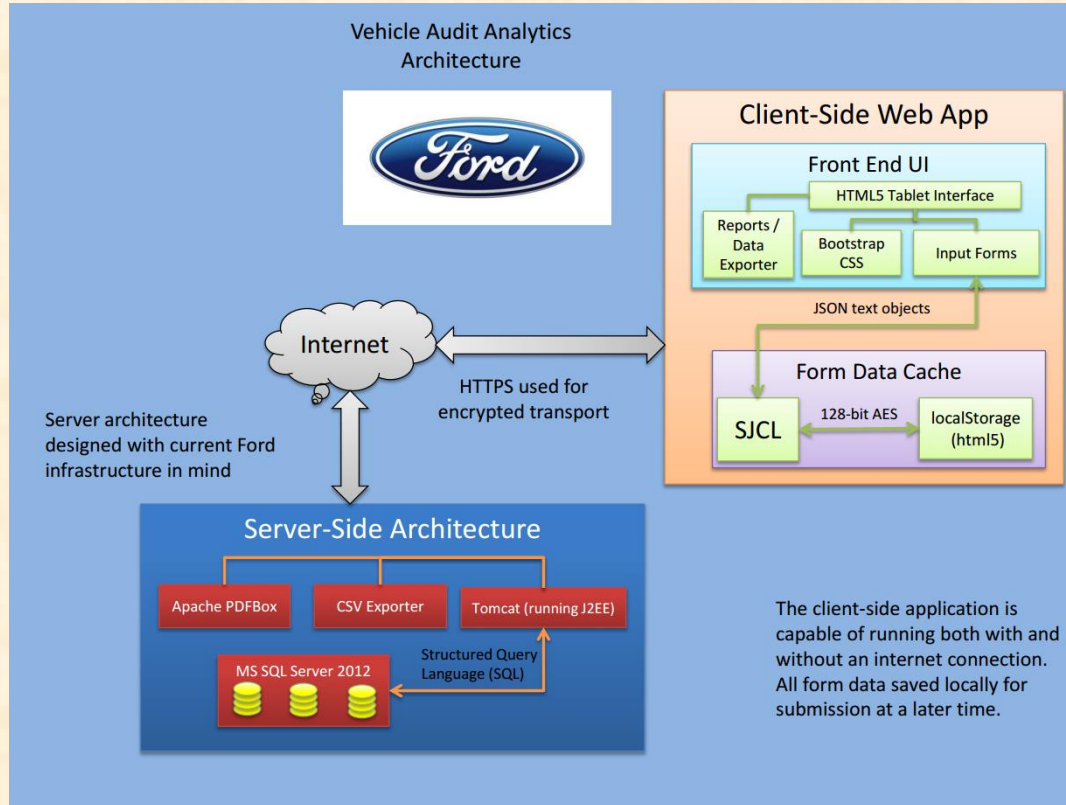

System Architecture

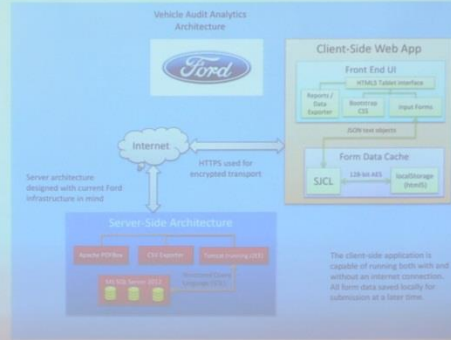

Team Ford Project Plan Presentation

Screen Mockup

 **Team Ford Project** Survey Update Upload Admin

Select Existing Survey: ▾

- 2015 Jeep Cherokee
- 2015 Porsche Cayenne

Project Information

Vehicle Year:

Vehicle Make:

Vehicle Model:

Vehicle Survey

Front console

| Feature | Rating | Media |
|----------------|--------------------------------|---|
| Speedometer | <input type="text" value="9"/> | <input type="button" value="Choose File"/> No file chosen |
| Clock | <input type="text" value="4"/> | <input type="button" value="Choose File"/> No file chosen |
| Radio | <input type="text" value="4"/> | <input type="button" value="Choose File"/> No file chosen |
| Dashboard | <input type="text" value="6"/> | <input type="button" value="Choose File"/> No file chosen |
| Steering Wheel | <input type="text" value="8"/> | <input type="button" value="Choose File"/> No file chosen |





Team Ford Alpha Presentation

Team Ford Alpha Presentation

Survey Page













iPad 4:00 PM 35.9.22.101 72%

 Vehicle Audit Analytics Survey Update Upload Admin













Vehicle Survey

All ▾

Front

| Feature | Rating | Media | Comments |
|---------------------|--------------------|---|--|
| Overall Appearance | Current Rating: 5▾ |    | <input type="text" value="Additional Comments"/> |
| Grille Appearance | Current Rating: 7▾ |    | <input type="text" value="Additional Comments"/> |
| Headlamp Appearance | Current Rating: 3▾ |    | <input type="text" value="Additional Comments"/> |
| Material Finishes | Current Rating: 5▾ |    | <input type="text" value="Additional Comments"/> |



Side

| Feature | Rating | Media | Comments |
|------------------------|--------------------|---|--|
| Overall Appearance | Current Rating: 0▾ |    | <input type="text" value="Additional Comments"/> |
| Window Appearance | Current Rating: 0▾ |    | <input type="text" value="Additional Comments"/> |
| Side Mirror Appearance | Current Rating: 2▾ |    | <input type="text" value="Additional Comments"/> |
| Material Finishes | Current Rating: 0▾ |    | <input type="text" value="Additional Comments"/> |









Rear

iPad 4:00 PM 35.9.22.101 72%









 Vehicle Audit Analytics Survey Update Upload Admin

Material Quality   

Overhead

| Feature | Rating | Media | Comments |
|--------------------|--------------------|---|--|
| Overall Appearance | Current Rating: 2▾ |    | <input type="text" value="Additional Comments"/> |
| Storage | Current Rating: 1▾ |    | <input type="text" value="Additional Comments"/> |
| Material Quality | Current Rating: 6▾ |    | <input type="text" value="Additional Comments"/> |

Trunk

| Feature | Rating | Media | Comments |
|--------------------|--------------------|---|--|
| Overall Appearance | Current Rating: 7▾ |    | <input type="text" value="Additional Comments"/> |
| Storage | Current Rating: 0▾ |    | <input type="text" value="Additional Comments"/> |
| Material Quality | Current Rating: 0▾ |    | <input type="text" value="Additional Comments"/> |



Team Ford Alpha Presentation Rating Dropdown & Front Survey

iPad 3:56 PM 35.9.22.101 73%

 Vehicle Audit Analytics Survey Update Upload Admin













Vehicle Information

Vehicle Year: 2016
Vehicle Make: Jeep
Vehicle Model: Grand Cherokee
Vehicle Series: SRT
Pricing: \$68,000

Vehicle Survey

Select Vehicle Area -

Front













| Feature | Rating | Media | Comments |
|---------------------|--|---|---------------------|
| Overall Appearance | Select rating: ▾ |    | Additional Comments |
| Grille Appearance | Select rating: 1 (Low rating) 2 3 4 5 (Medium rating) 6 7 8 9 10 (Best rating) |    | Additional Comments |
| Headlamp Appearance | |    | Additional Comments |
| Material Finishes | |    | Additional Comments |

Survey

iPad 3:59 PM 35.9.22.101 72%

Vehicle Survey

Front

| Feature | Rating | Media | Comments |
|---------------------|--------------------|---|----------------------------|
| Overall Appearance | 8 ▾ |    | Sleek look |
| Grille Appearance | 10 (Best rating) ▾ |    | Upgraded jeep grille style |
| Headlamp Appearance | Select rating: ▾ |    | Additional Comments |
| Material Finishes | Select rating: ▾ |    | Additional Comments |

Save Survey

and the to
Q W E R T Y U I O P
A S D F G H J K L return
Z X C V B N M ! ?
.?123





Team Ford Alpha Presentation

Team Ford Alpha Presentation

Adding a Photo

The screenshot shows the 'Vehicle Audit Analytics' app interface on an iPad. The top status bar displays 'iPad', signal strength, '3:56 PM', and '35.9.22.101'. The app header includes the Ford logo and navigation links: 'Survey', 'Update', 'Upload', and 'Admin'. The main content is divided into two sections: 'Vehicle Information' and 'Vehicle Survey'.

Vehicle Information

| | |
|----------------|----------------|
| Vehicle Year | 2016 |
| Vehicle Make | Jeep |
| Vehicle Model | Grand Cherokee |
| Vehicle Series | SRT |
| Pricing | \$68,000 |

Vehicle Survey

Select Vehicle Area ▾

Front

| Feature | Rating | Media | Comments |
|---------------------|------------------|--------|---------------------|
| Overall Appearance | Select rating: ▾ | 📷 | |
| Grille Appearance | Select rating: ▾ | 📷 📹 🗣️ | Additional Comments |
| Headlamp Appearance | Select rating: ▾ | 📷 📹 🗣️ | Additional Comments |
| Material Finishes | Select rating: ▾ | 📷 📹 🗣️ | Additional Comments |

Save Survey

Take Photo or Video
Photo Library





Team Ford Beta Presentation

Team Ford Beta Presentation

Survey Tab















iPad 7:57 PM 35.9.22.101 98%

Vehicle Audit Analytics  Survey Update Upload Admin Reports

Vehicle Survey

Select Vehicle Area ▾

Front

| Feature | Rating | Media | Comments |
|---------------------|------------------|---|--|
| Overall Appearance | Select rating: ▾ |    View Media | <input type="text" value="Additional Comments"/> |
| Grille Appearance | Select rating: ▾ |    View Media | <input type="text" value="Additional Comments"/> |
| Headlamp Appearance | Select rating: ▾ |    View Media | <input type="text" value="Additional Comments"/> |
| Material Finishes | Select rating: ▾ |    View Media | <input type="text" value="Additional Comments"/> |
| Hood Appearance | Select rating: ▾ |    View Media | <input type="text" value="Additional Comments"/> |



Team Ford Beta Presentation

View Media

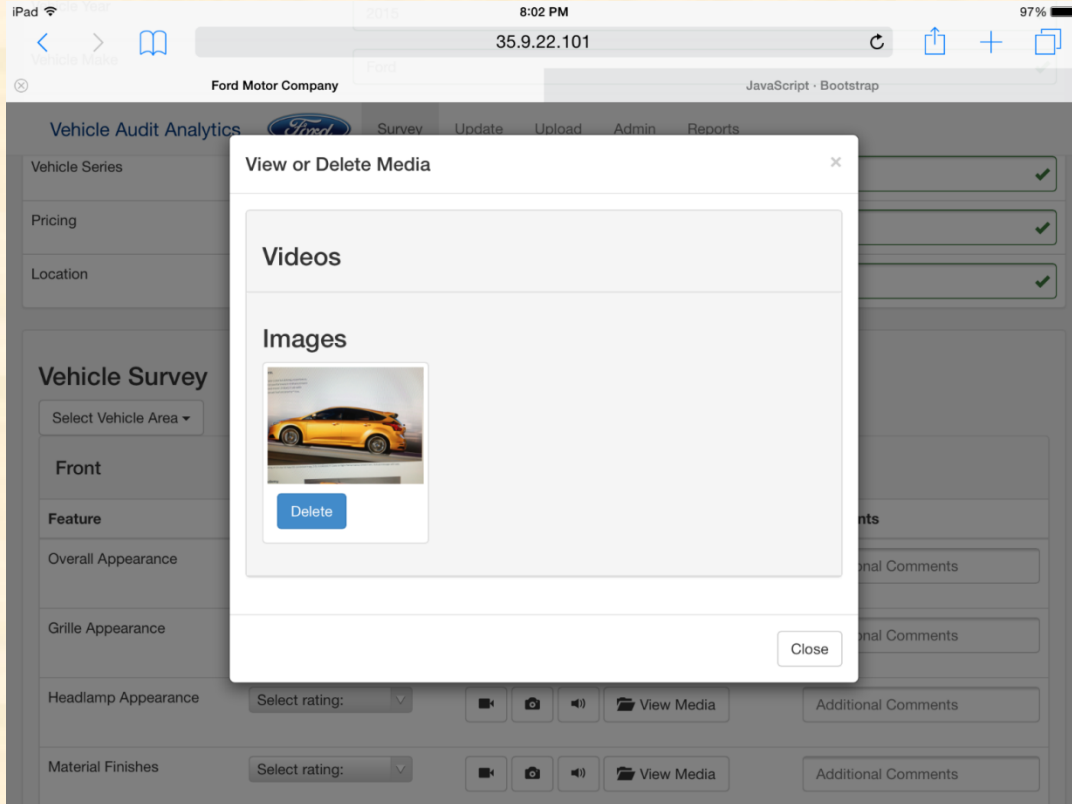



Team Ford Beta Presentation

Team Ford Beta Presentation

Reports Tab

iPad 8:06 PM 35.9.22.101 96%

Vehicle Audit Analytics  Survey Update Upload Admin Reports

Vehicle Make

Vehicle Model

Vehicle Series

Location

Search

Reports for Selection:

- 2015 Ford Mustang
- Username: test | 2000 Jeep Grand Cherokee
- 2015 Ford Mustang
- 2015 Ford Mustang
- Username: test | 2014 Jeep Grand Cherokee
- Username: test | 2014 Jeep Grand Cherokee
- Username: o | 2002 Ford Mustang
- Username: o | 2002 Ford Mustang
- 2015 Ford Mustang

Create Report [Click Here for Excel File.](#)



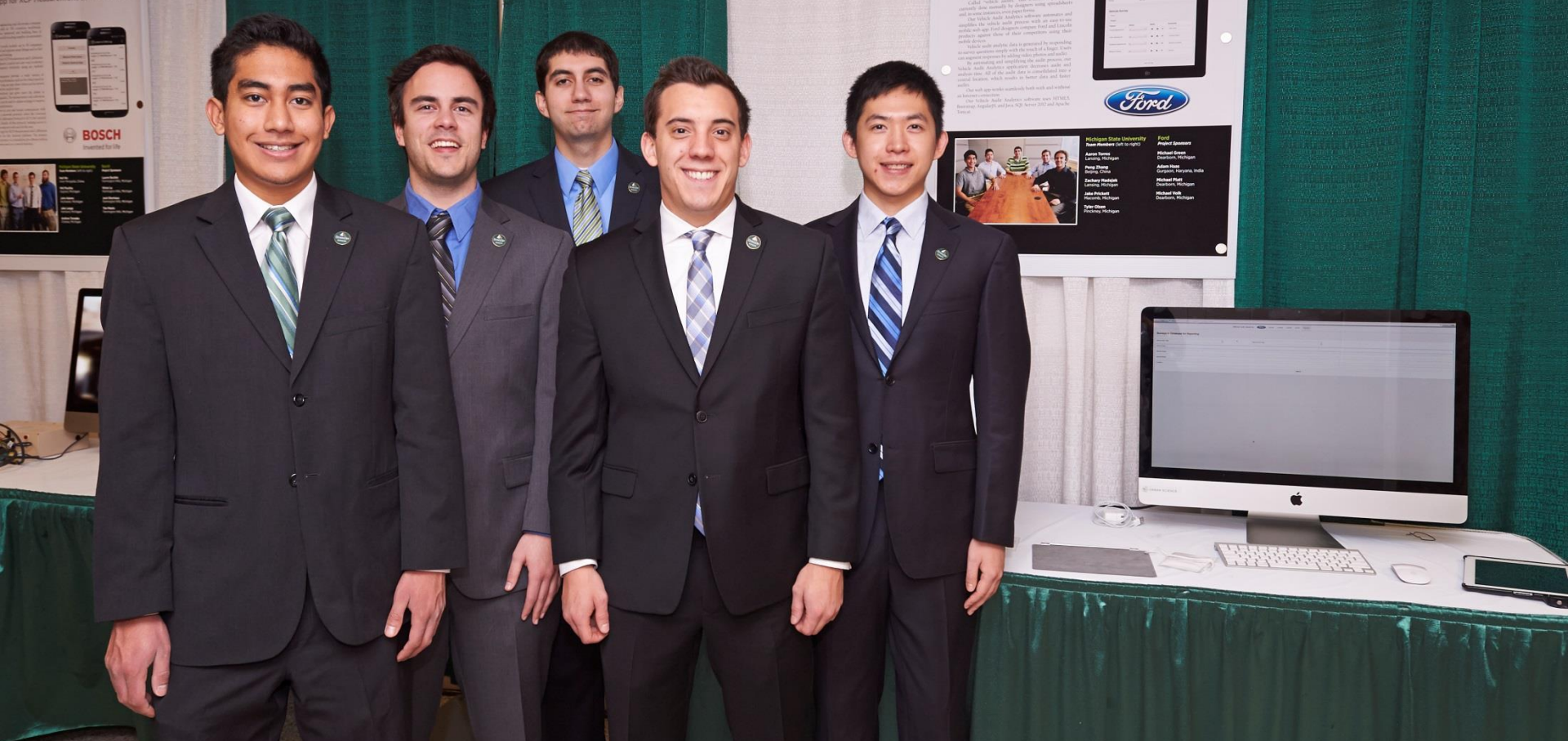

Team Ford Design Day

MICHIGAN STATE

UNIVERSITY

The Capstone Experience

Team GM

Department of Computer Science and Engineering
Michigan State University
Fall 2014



*From Students...
...to Professionals*





THE LATEST FROM GM:

1 2 3 4 5

Chevrolet Introduces Two New Sedans to Sonic Family

LOS ANGELES - Chevrolet today announced two new sedan options to the Sonic lineup in 2014 - the performance-inspired RS and the stylish Dusk - further demonstrating the brand's commitment to the subcompact segment and to... [Read](#)

Team GM

Project Overview

Productivity Toolbar (aka Fast App Launcher)

- Functionalities
 - Organize and Launch Commonly Used Apps
 - Via
 - Web Browser
 - Windows Desktop App
- Features
 - Provide Individualized App Organization
 - Add and Delete
 - Configuration
 - Layout
 - Support Internet Explorer, Chrome and Firefox
 - Handle Apps Pushed by Corporate
 - Interface with Library of Available Apps
 - Base on User's Authenticated Identity
- Technologies
 - CSS, HTML, JavaScript
 - Internet Explorer, Chrome and Firefox
 - Microsoft .NET, Visual Studio

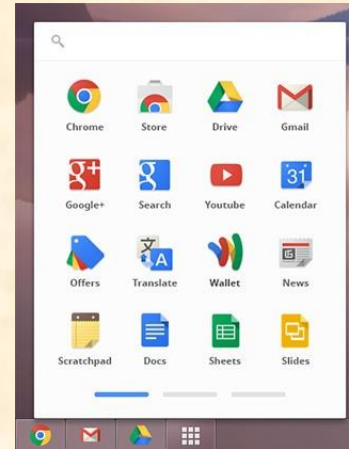

Detroit, Michigan

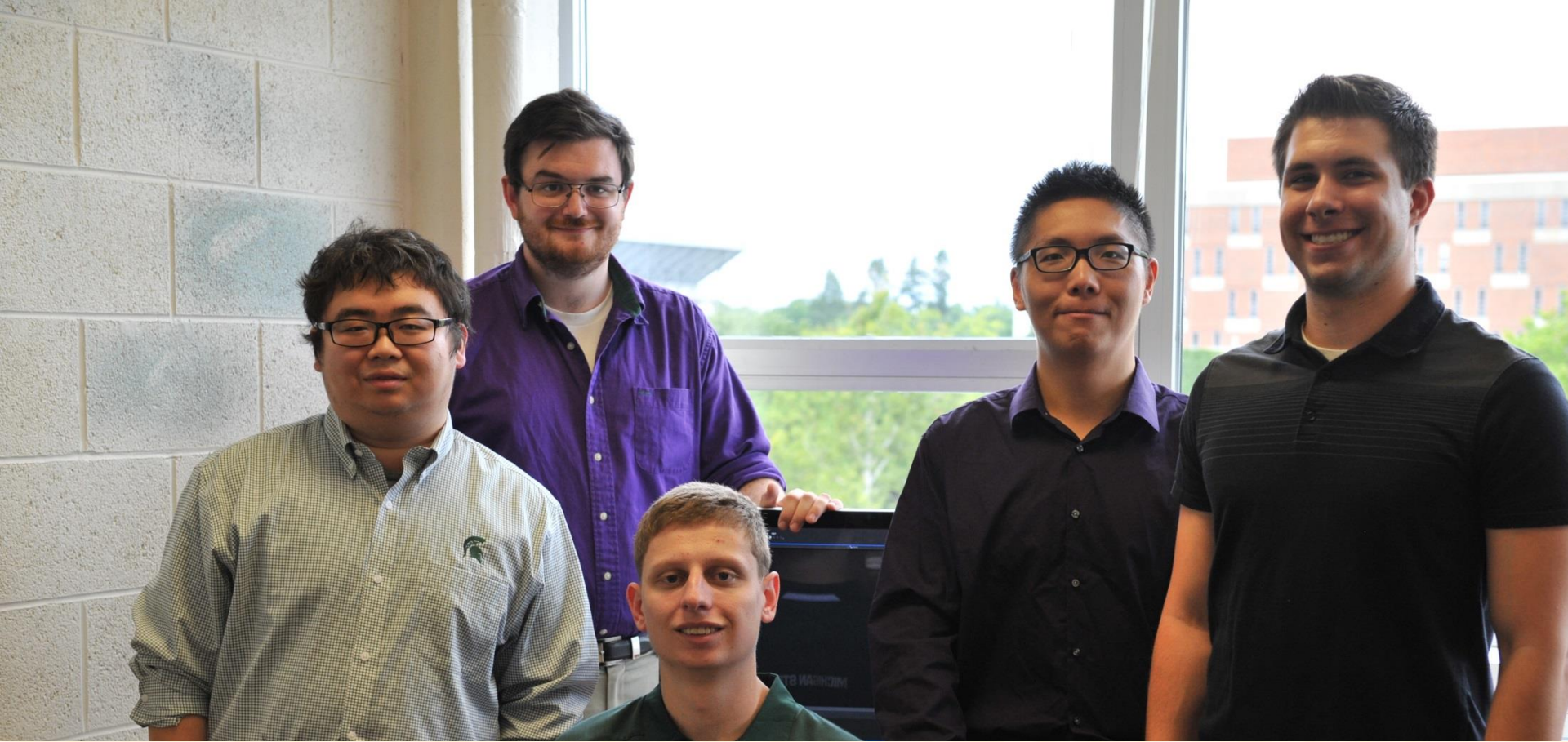

Team GM

Ruoqing Chen, David Barrie, Kevin Piotrowski, Kan Zhou, Justin Rucinski

Team GM Project Plan Presentation

Screen Mockup

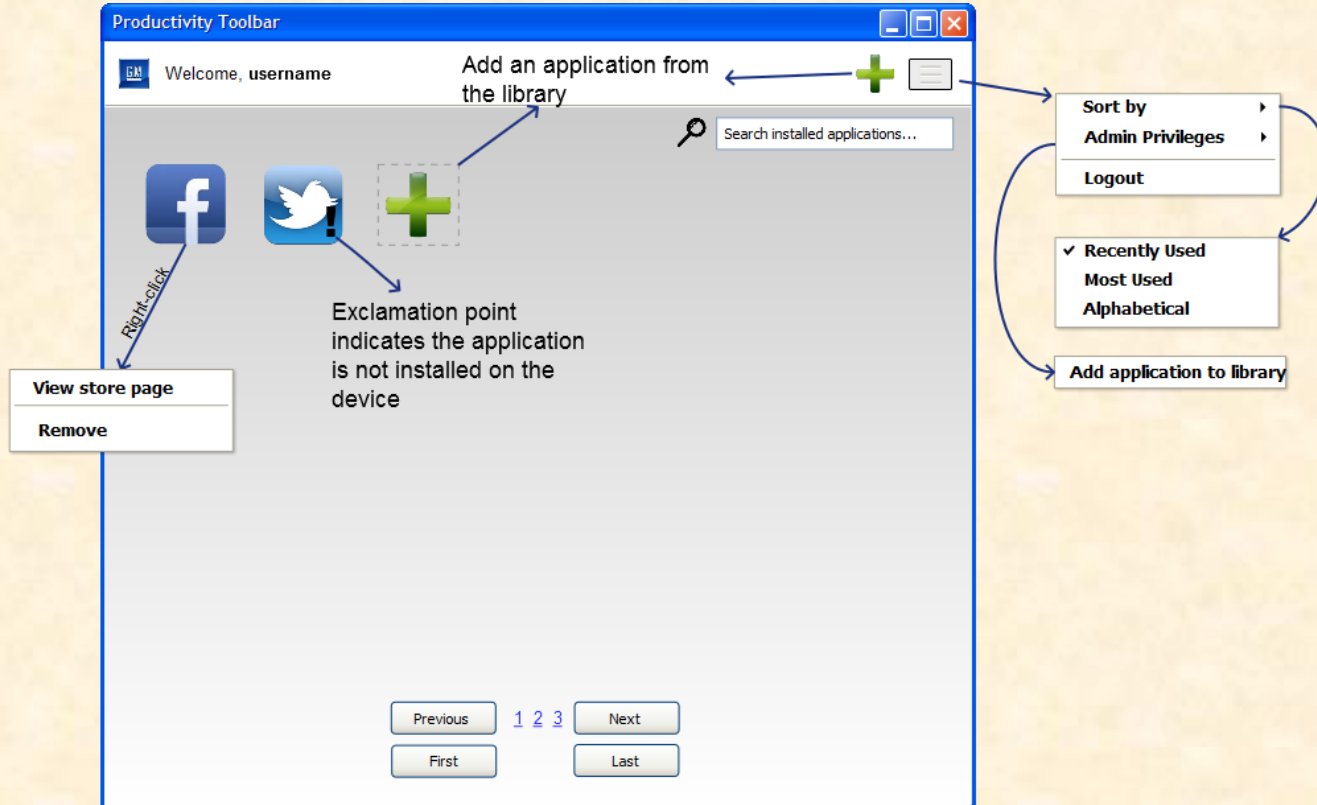



Team GM Project Plan Presentation

Team GM Project Plan Presentation

Architecture Diagram

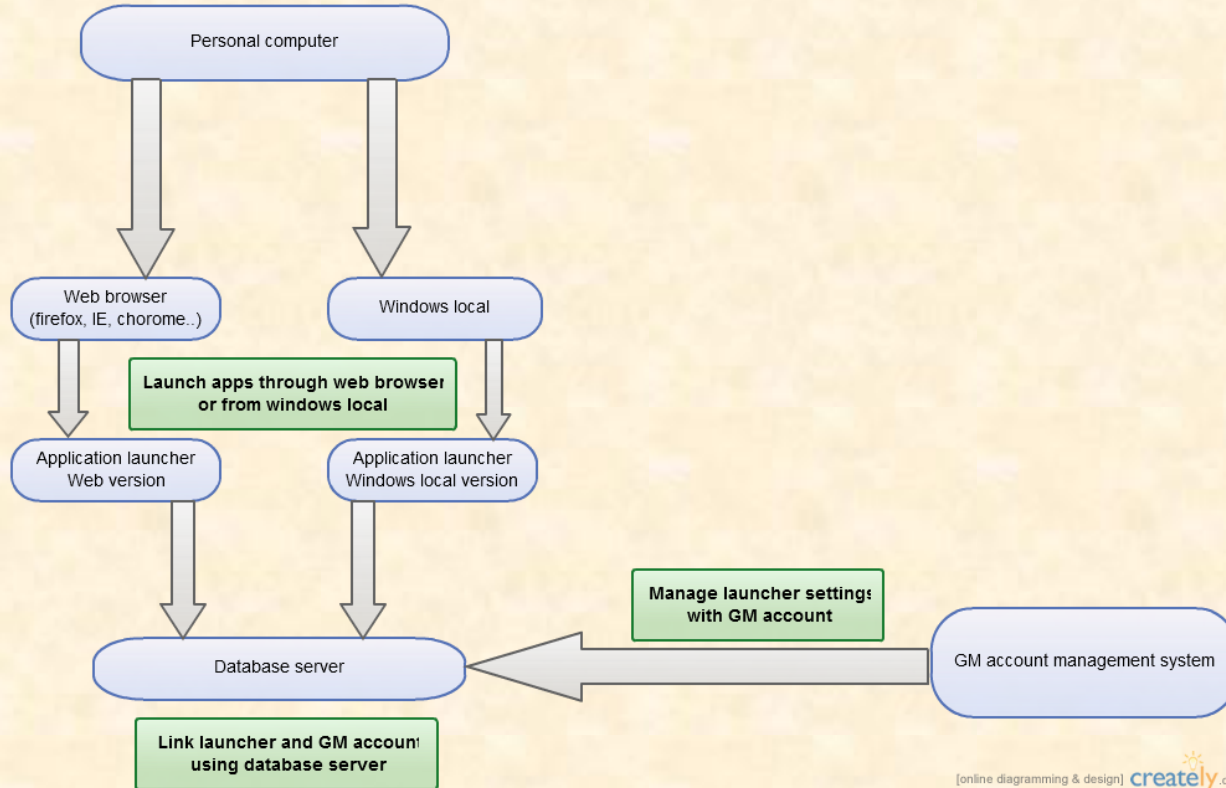

System Architecture

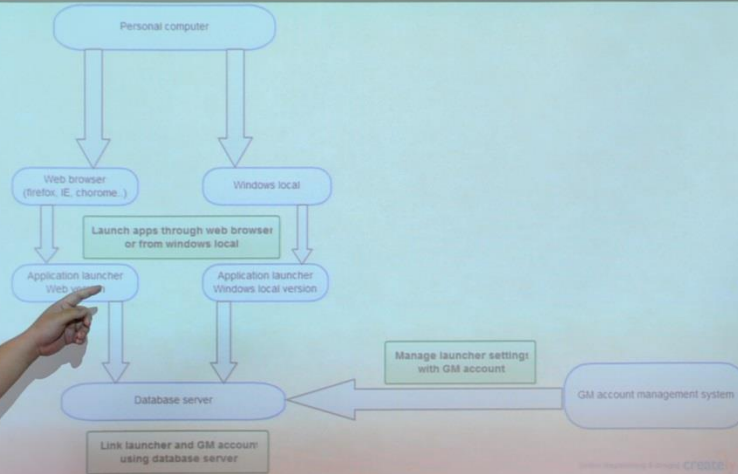

Team GM
Project Plan Presentation

Team GM Project Plan Presentation

Screen Mockup

<http://gmaplibrary.com>

Administrator options

- Edit properties**
- Remove application**

Application: *application name*
Version: *version #*
Description: *description...*

Download





Team GM Alpha Presentation

Team GM Alpha Presentation

Desktop User App Panel

The screenshot displays the 'USER'S APPLICATION PANEL' desktop environment. On the left is a vertical sidebar with four main sections: 'Applications' (GM logo), 'GM App Store' (GM logo), 'Settings' (blue folder with GM logo and pens), and 'Login/Logout' (Chevrolet logo). The main panel features a grid of application icons: Link Sink, myTravel, SOCRATES, ERMS, Books 24x7, CAP, getAbstract, IT Support, GM Overdrive, e-Approval, Webmail, and Peoplefinder. On the right side, there is a vertical navigation menu with four numbered buttons: 'Office 1', 'Social 2', 'Education 3', and 'Learning 4'. At the bottom, there are 'prev' and 'next' navigation buttons and a page number '1'. A red 'X' icon is located in the top right corner of the panel.

Team GM Alpha Presentation

Desktop Add App Panel

The screenshot displays a desktop application panel titled "ADD APPLICATION PANEL" with a red close button in the top right corner. On the left side, there is a vertical navigation menu with four items: "Applications" (GM logo), "GM App Store" (GM logo), "Settings" (blue folder with GM logo and pens), and "Login/Logout" (Chevrolet logo). The main area contains a grid of application icons: "e-Approval" (red icon with gear and "e-Approval"), "ERMS" (green icon with dollar signs and "ERMS"), "getAbstract" (blue icon with curly braces and "get Abstract"), "IT Support" (red icon with "iT"), "Link Sink" (blue icon with a sink), "myTravel" (blue icon with a suitcase and "myTravel"), "GM Overdrive" (green icon with "H"), "Peoplefinder" (blue icon with people and "A B C D"), and "Webmail" (blue icon with an envelope). On the right side, there is a vertical list of categories: "Office 1", "Social 2", "Education 3", and "Learning 4". At the bottom, there are navigation buttons: "prev", "1", and "next".



Team GM Alpha Presentation

Team GM Alpha Presentation

Web Launcher

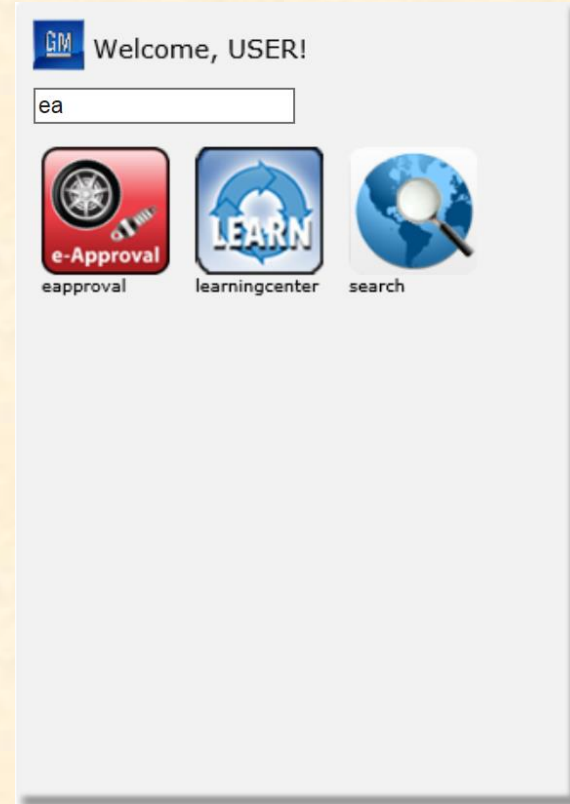



Team GM Beta Presentation

Team GM Beta Presentation

Web Launcher



Team GM Beta Presentation

Desktop Launcher

































Team GM Beta Presentation

Team GM Beta Presentation

Web App Store

| | | | | | | | | |
|---|---|---|--|---|--|--|--|--|
| Books 24x7  | CAP  | e-Approval  | ERMS  | getAbstract  | IT Support Center  | Learning Center  | Link Sink  | myTravel Approval  |
| GM Overdrive  | Peoplefinder  | Socrates  | Webmail  | Messenger  | Office Notes  | W Explorer  | Favorites  | Climber  |
| Security  | Interact  | WebEx  | Manufacturing  | App Management  | Photo Editor  | Adobe  | Maps  | Charts  |
| Recruiting  | FlightFinder  | Cafeteria  | Video Player  | Workflows  | Roundtable  | Designer  | | |

Selected User:

Users:

User's Apps



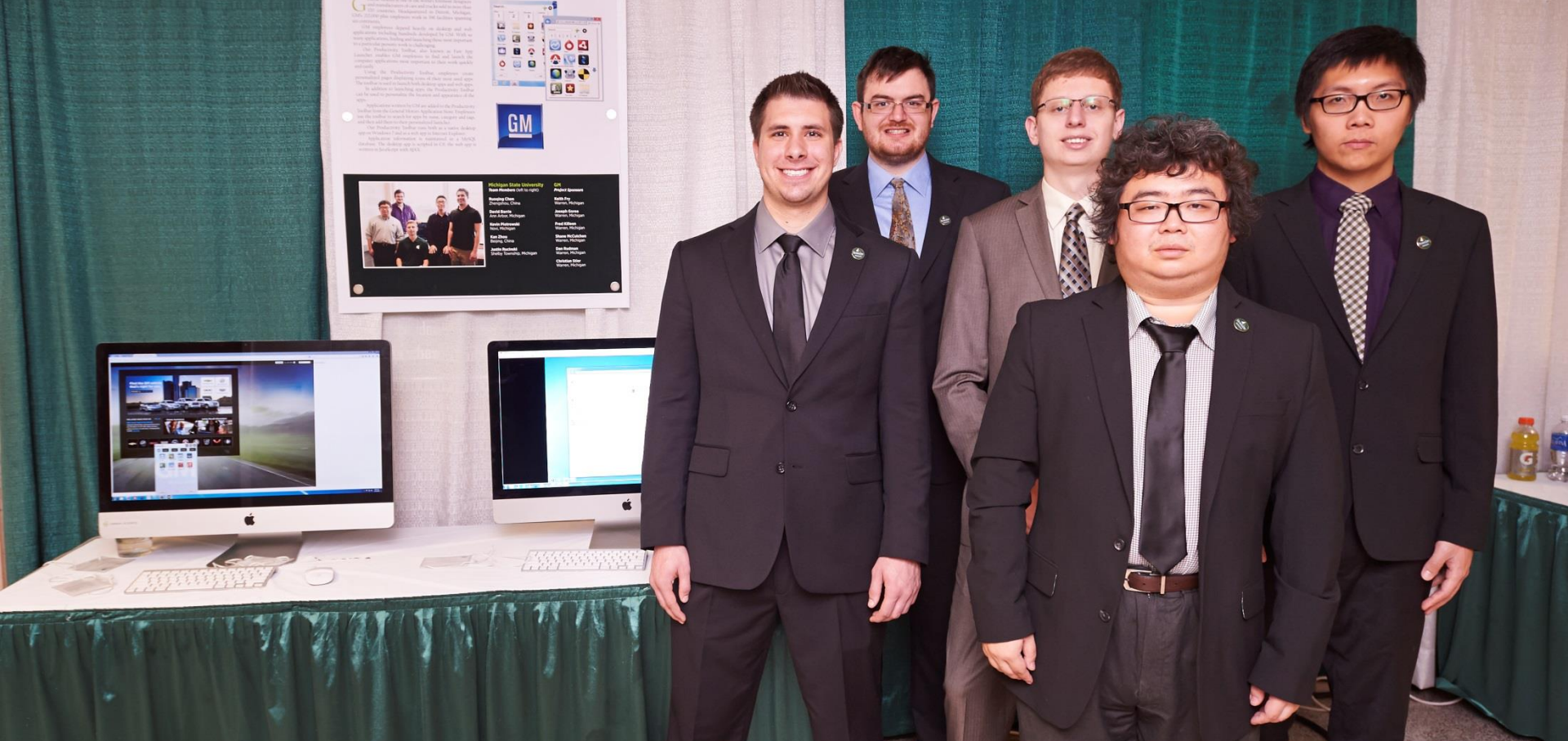

Team GM
Design Day

MICHIGAN STATE
UNIVERSITY

The Capstone Experience

Team Meijer

Department of Computer Science and Engineering
Michigan State University
Fall 2014



*From Students...
...to Professionals*

meijer[®]



protein your whole family will love *plus delicious new ways to enjoy breakfast or a snack* [learn more](#)

meijer

mperks.
Coupons & Rewards

m weekly ads
Save in Stores

Buy Gift Cards

Credit Card

Pharmacy

Photo

[Find a Store](#)

[My Store](#)

[My Account](#)

[Cart](#) 0



A different
experience
that begins the
moment you step
inside the door.

Team Meijer Project Overview

Mobile Location-Based Product Promotion

- Functionalities
 - Make Meijer Customer Aware of Sale Items
 - Based On Customer's
 - Location in Store
 - Shopping Preferences
 - Via Customer's Mobile Device
- Features
 - Support
 - Weekly Sale Items
 - Vendor Promotional Dollars
 - Generate and Present Analytics
 - Integrate with Customer's mPerks Account
 - Provide System Administrator Interface
- Technologies
 - Xamarin or PhoneGap
 - iBeacon
 - Crashlytics
 - Mobile Development (Apple iOS or Google Android)
 - Microsoft .NET, Azure Mobile Service
 - Meijer Web Services

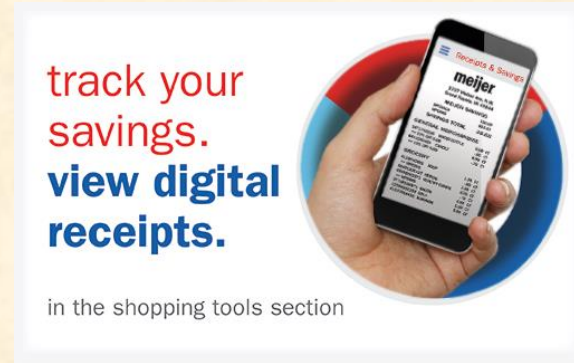

meijer[®]

Grand Rapids, Michigan



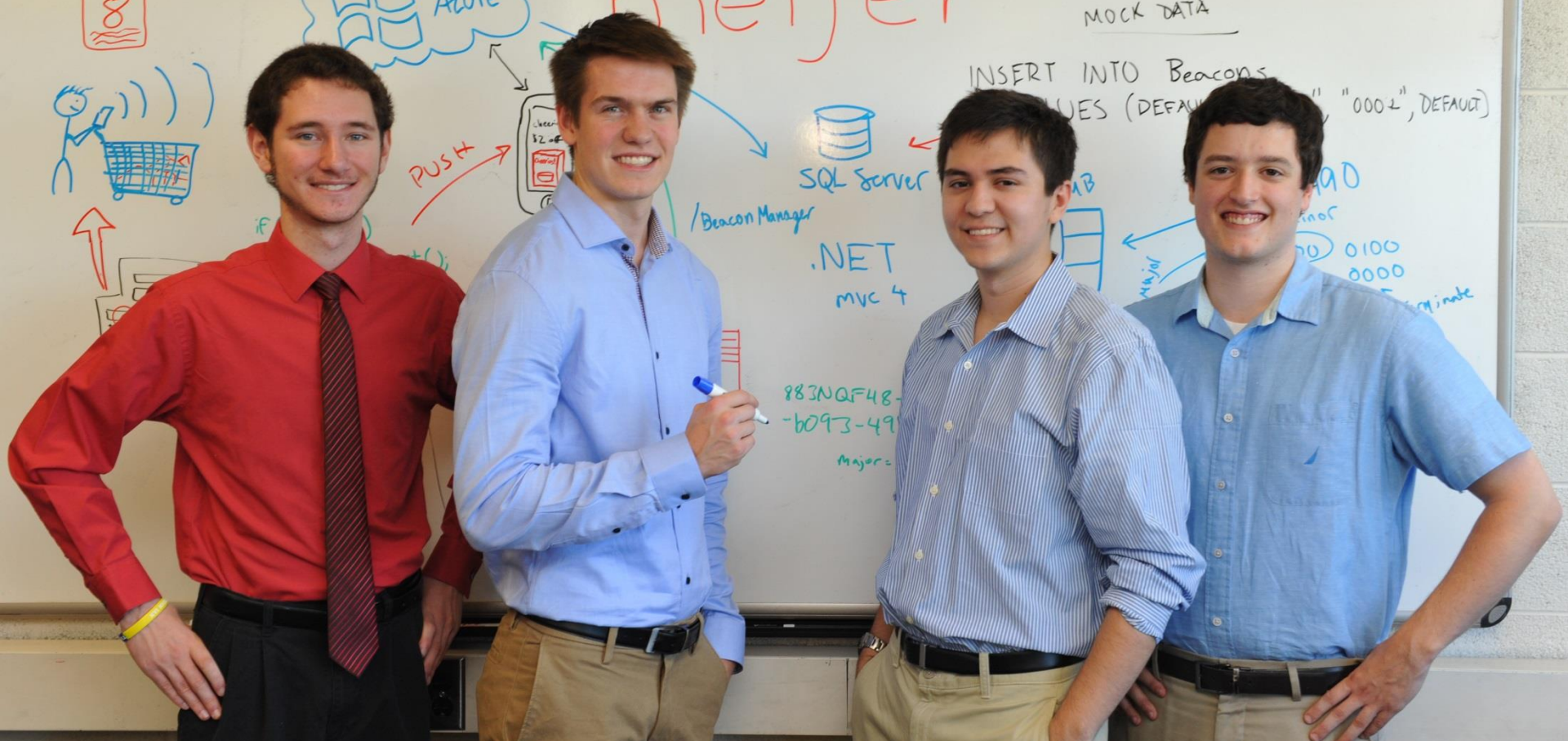

Team Meijer

Dan Leclerc, Jason Bull, Xavier Durand-Hollis, Kevin Pauly

Team Meijer Project Plan Presentation

Screen Mockup

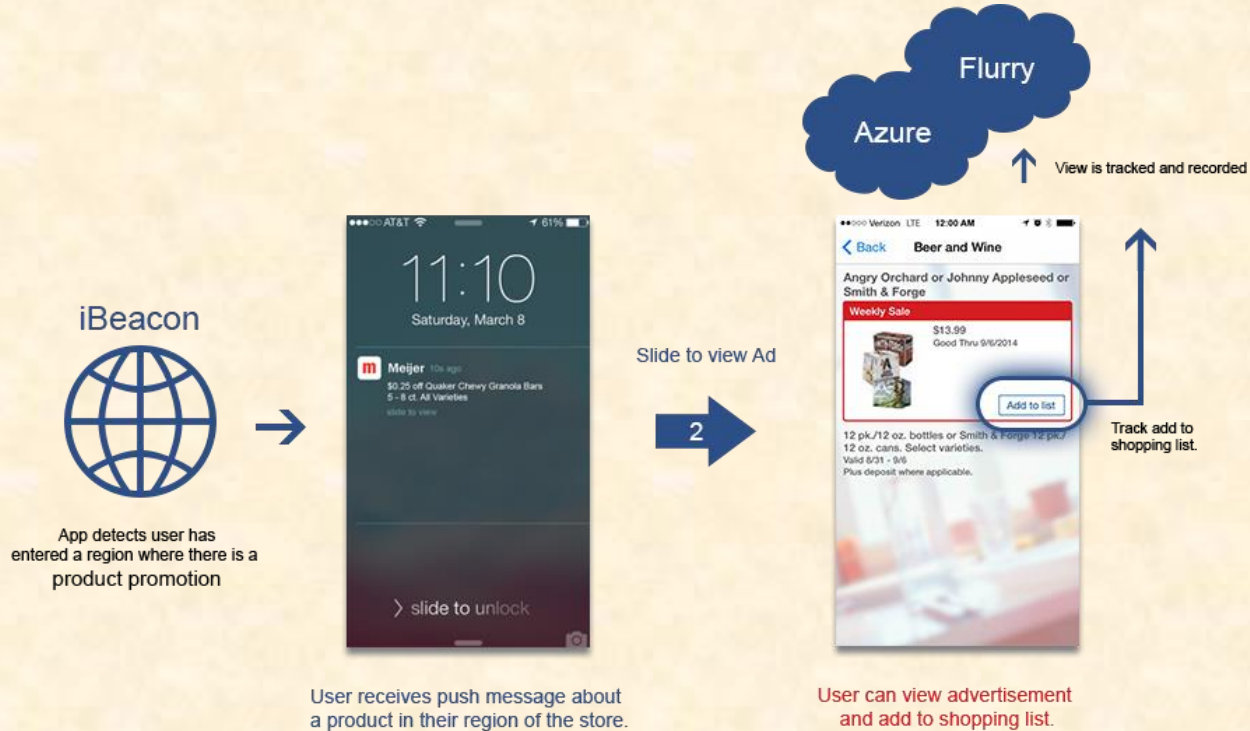

User receives push message about a product in their region of the store.

User can view advertisement and add to shopping list.





Team Meijer Project Plan Presentation

Team Meijer Project Plan Presentation

Architecture Diagram

Systems Architecture

TEAM MEIJER - FALL 2014

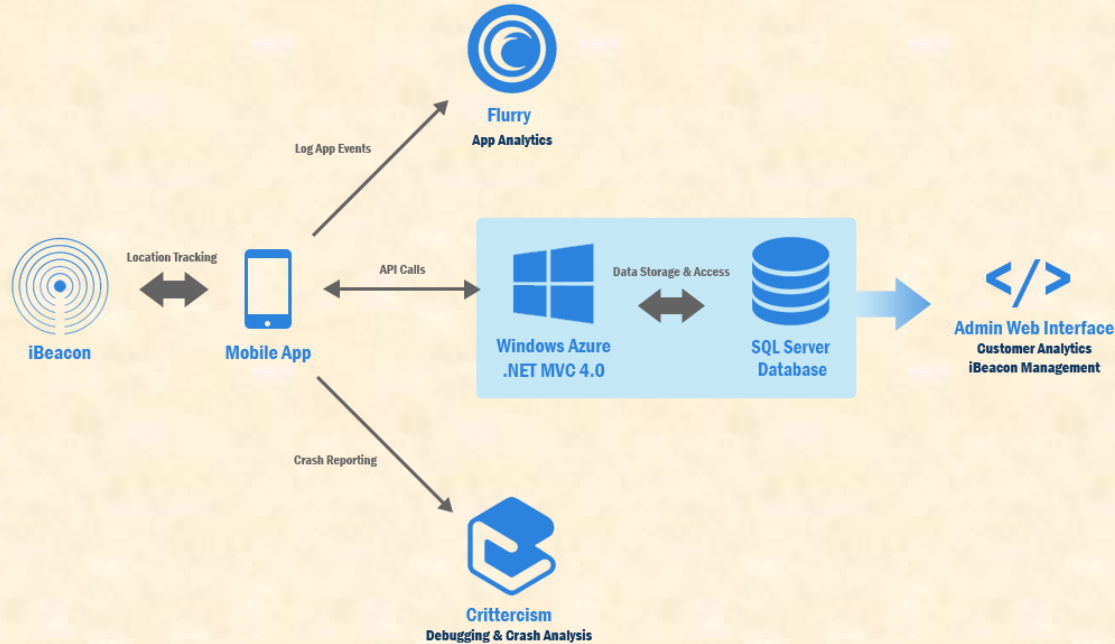



Team Meijer Project Plan Presentation

Team Meijer Project Plan Presentation

Screen Mockup

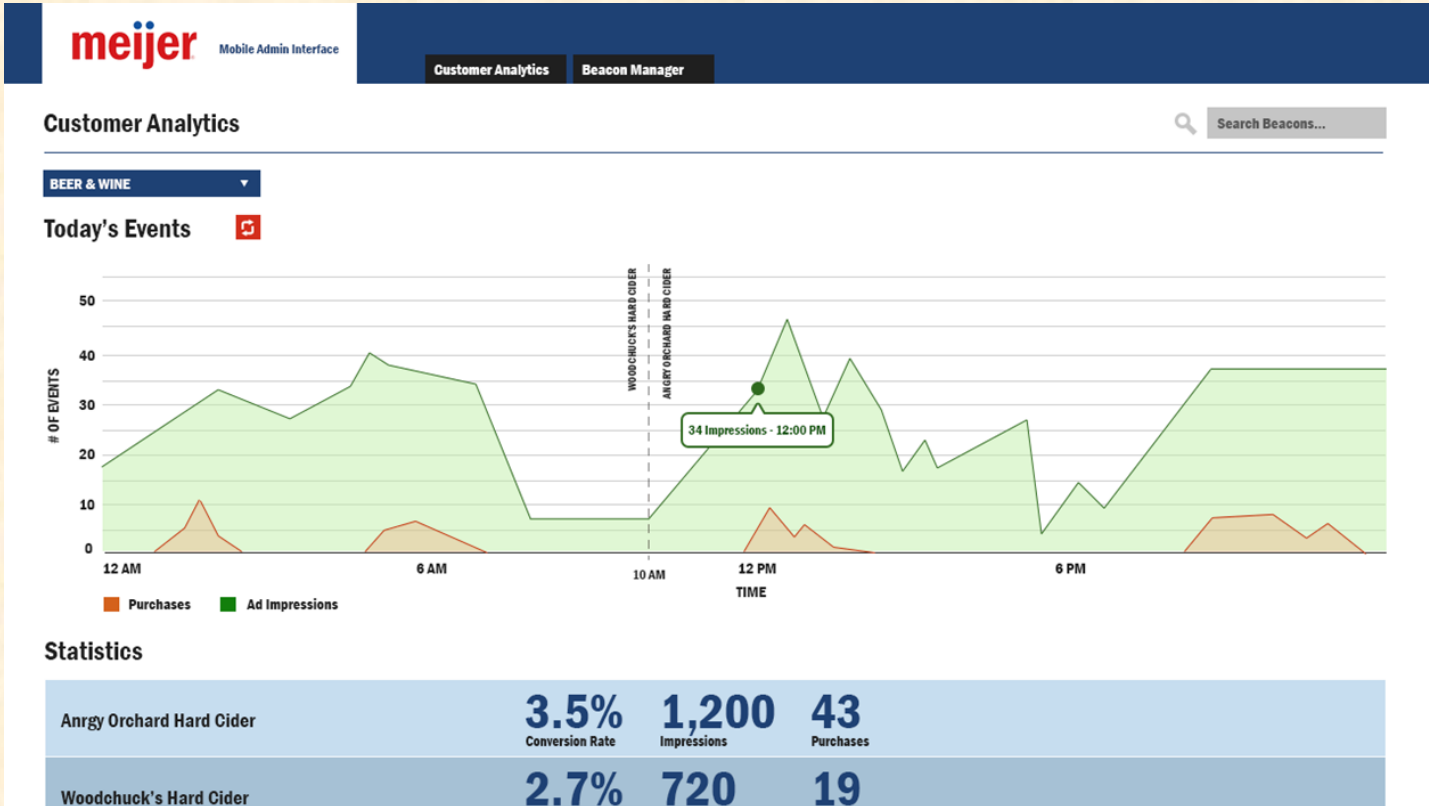



Team Meijer Alpha Presentation

Team Meijer

Alpha Presentation

Product Promotion Notifications

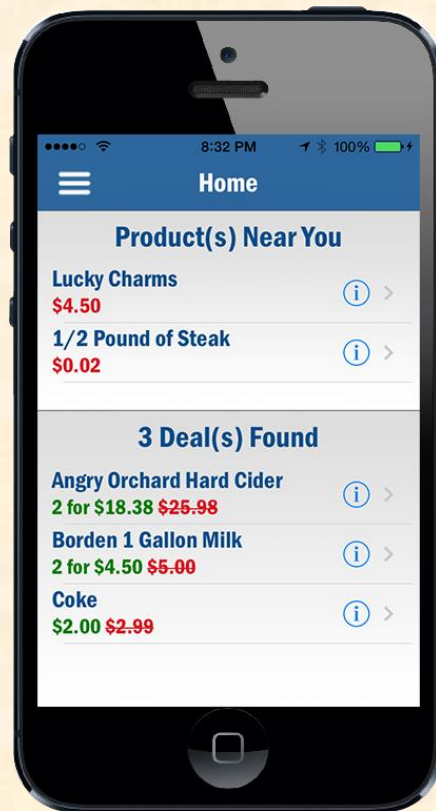
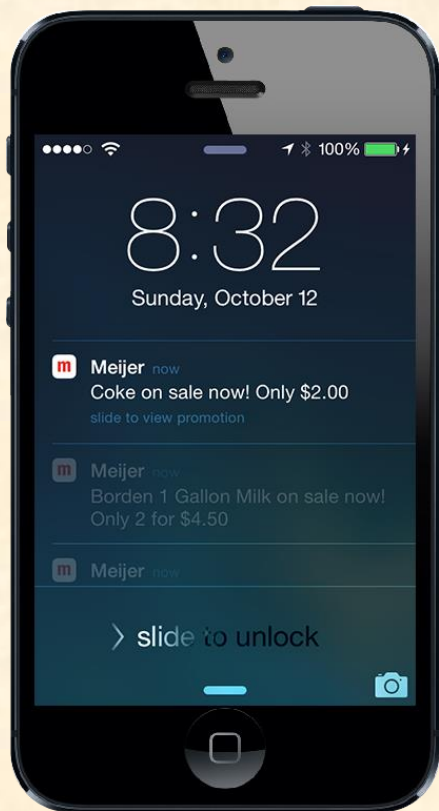

Team Meijer Alpha Presentation

Promotion Details and Settings

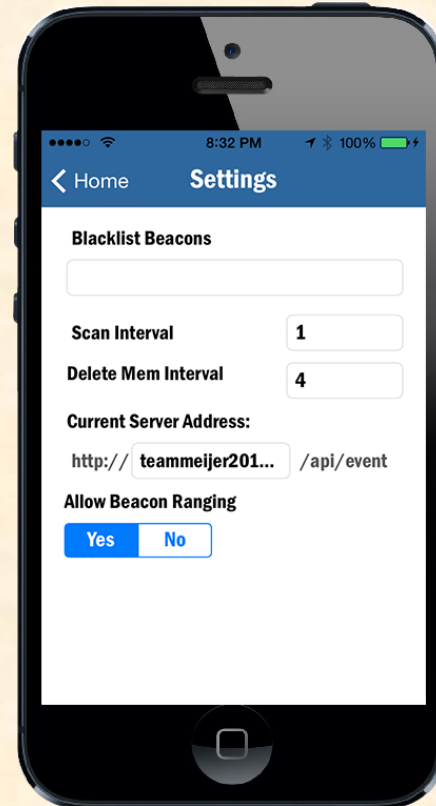

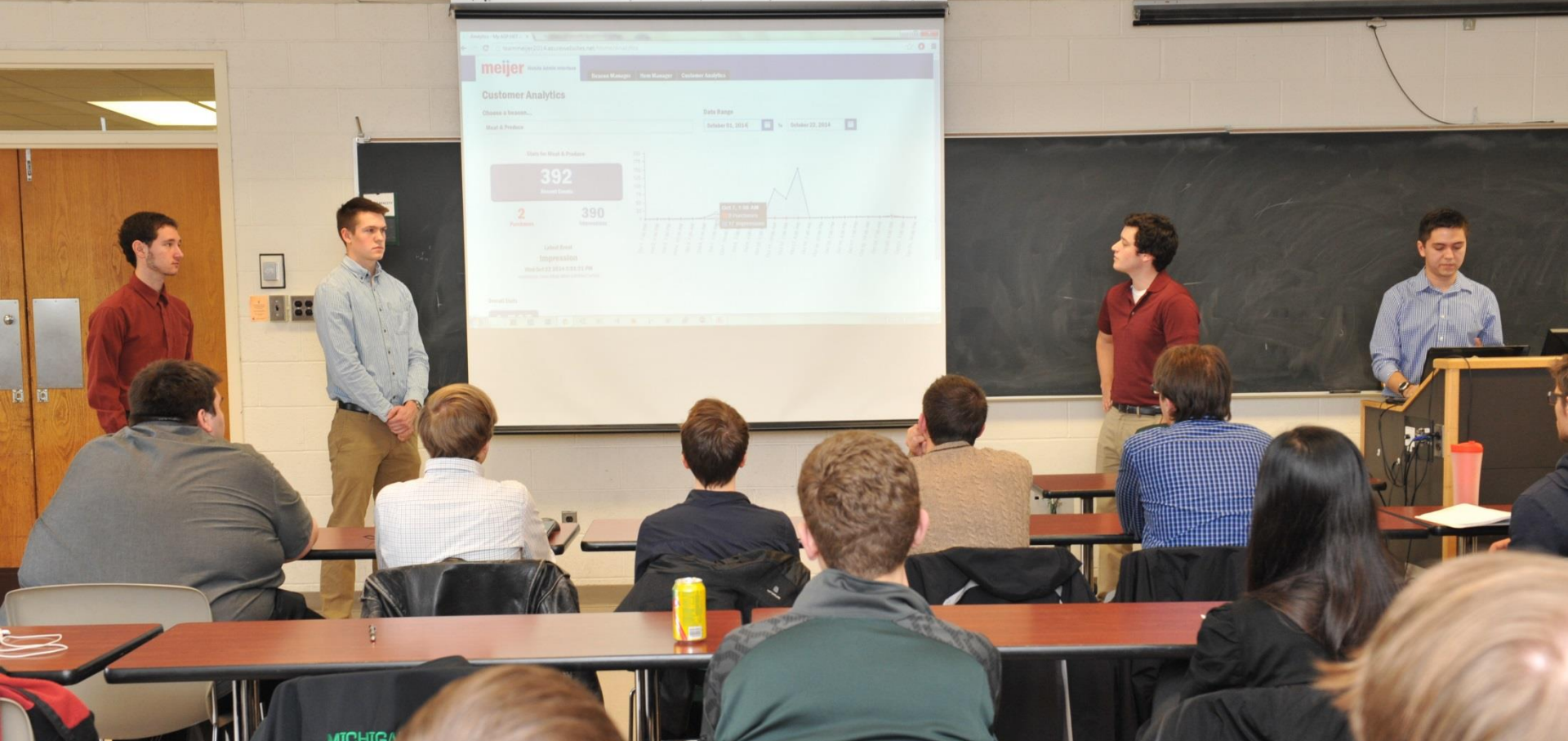

Team Meijer
Alpha Presentation

Team Meijer Alpha Presentation

Beacon Manager

The screenshot displays the Meijer Beacon Manager mobile admin interface. The browser address bar shows the URL `teammeijer2014.azurewebsites.net`. The page header includes the Meijer logo and the text "Mobile Admin Interface". Navigation tabs for "Beacon Manager", "Item Manager", and "Customer Analytics" are visible. The main content area is titled "Beacon Manager" and features a "Tools" sidebar on the left with input fields for "Name", "Major ID", and "Minor ID", along with an "Add Beacon" button. The main list displays several beacons:

| Category | Item ID | Name | Status | Action |
|----------------|----------------------|--------------------------|----------|--------|
| Meat & Produce | 734 - 35990 | 1/2 Pound of Steak | ACTIVE | EDIT |
| Dairy | 22046 | | DELETE | |
| | 14713 | | SAVE | |
| | Borden 1 Gallon Milk | | CANCEL | |
| Soft Drinks | 42587 - 19852 | Coke | ACTIVE | EDIT |
| Cereal | 56625 - 32169 | Lucky Charms | ACTIVE | EDIT |
| Beer & Wine | 24101 - 40971 | Angry Orchard Hard Cider | ACTIVE | EDIT |
| Music | 3958 - 41769 | Tha Doggfather | INACTIVE | EDIT |





Team Meijer Beta Presentation

Team Meijer Beta Presentation

Product Promotions

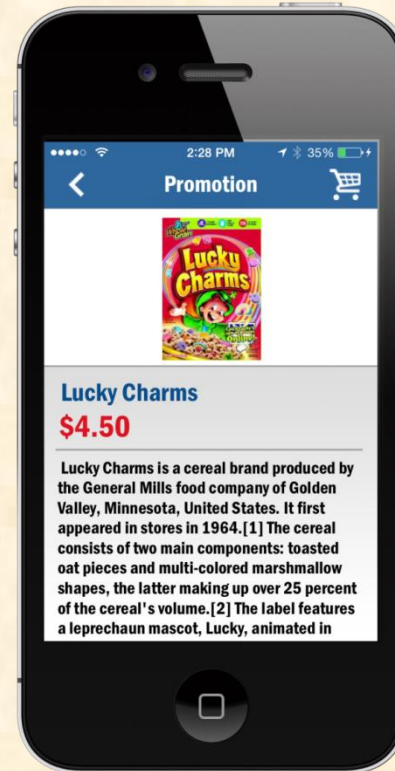
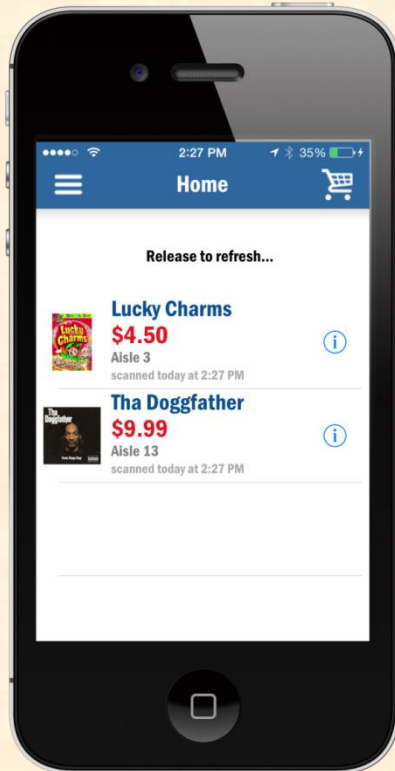

Team Meijer Beta Presentation

Shopping Cart

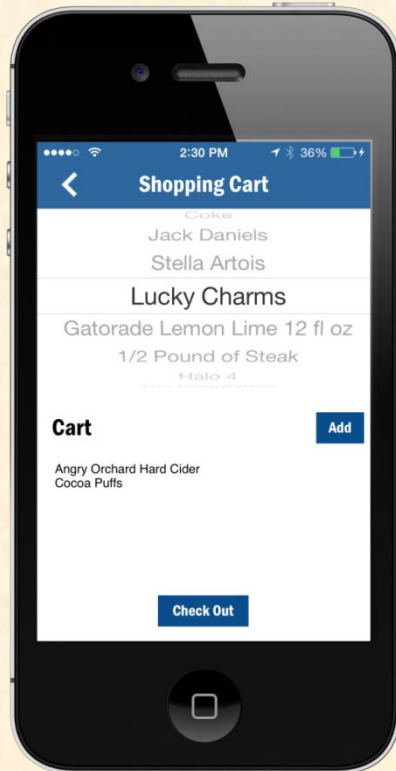



Team Meijer Beta Presentation

Team Meijer Beta Presentation

Beacon Manager

The screenshot shows the Meijer Beacon Manager web application. The browser address bar displays 'teammeijer2014.azurewebsites.net'. The application header includes the Meijer logo and 'Mobile Admin Interface' with navigation tabs for 'Beacon Manager', 'Item Manager', and 'Customer Analytics'. The main content area is titled 'Beacon Manager' and features an 'Add Beacon' form on the left and a list of beacons on the right. The 'Add Beacon' form has fields for 'Name', 'Major ID', and 'Minor ID', and a 'Create' button. The beacon list includes items like 'Meat & Produce', 'Sports Drinks', 'Soft Drinks', 'Meijer Campus Beacon 3', 'Meijer4', 'Cereal', 'Beer & Wine', 'MeijerCampusBeacon', and 'Music', each with an 'ACTIVE' status and 'EDIT' and 'STATS' buttons.

| Beacon ID | Item Name | Status | Actions |
|---------------|------------------------------|--------|------------|
| 734 - 35990 | Cheerios | ACTIVE | EDIT STATS |
| 22046 - 14713 | Gatorade Lemon Lime 12 fl oz | ACTIVE | EDIT STATS |
| 42587 - 19852 | Coke | ACTIVE | EDIT STATS |
| 28278 - 39958 | Cocoa Puffs | ACTIVE | EDIT STATS |
| 39676 - 57092 | Jack Daniels | ACTIVE | EDIT STATS |
| 56625 - 32169 | Lucky Charms | ACTIVE | EDIT STATS |
| 24101 - 40971 | Angry Orchard Hard Cider | ACTIVE | EDIT STATS |
| 43429 - 10900 | Gatorade Lemon Lime 12 fl oz | ACTIVE | EDIT STATS |
| | Music | ACTIVE | EDIT STATS |





Team Meijer
Design Day

MICHIGAN STATE

UNIVERSITY

The Capstone Experience

Team MSUFCU

Department of Computer Science and Engineering
Michigan State University
Fall 2014



*From Students...
...to Professionals*



F E D E R A L C R E D I T U N I O N

Building Dreams *Together*



[f](#) 9,545 people like this. [Sign Up](#) to see what your friends like.

[Personal](#)
[Business](#)
[Account Services](#)
[Join MSUFCU](#)

V.me by Visa is here.

It's the free virtual wallet that is
secure, personal, and simple.



What's New @ MSUFCU

Parents - Our Financially Made Contest is back!

New educational Money.edu app is available

Simplify your finances with MSUFCU's Bill Payment

Upcoming Events

MSUFCU Day at MSU Women's Volleyball

Friday, November 22

[View all events >>](#)

[Locations](#)
[ATMs](#)
[Careers](#)
[FAQs](#)
[Forms & Applications](#)
[Rates](#)
[About Us](#)
[Contact Us](#)

 Search



Search Site or Find ATMs by City, State or Zip

[MSUFCU ID Sign In](#)

MSUFCU Routing Number: 272479663

MSUFCU SWIFT Code: MSUCUS44

ComputerLine - Protected by TrulyU®

 Base Account #

 Password

Request Password



Online Chat
is currently
unavailable



Send Us a
Secure Email

800-678-4968 • 517-333-2424

Mon-Fri: 7:00 a.m. - 9:00 p.m. ET

Sat: 9:00 a.m. - 3:00 p.m. ET



Current Rates

[Loans](#)
[Home Loans](#)
[Savings](#)
[Business](#)

Team MSUFCU Project Overview

Refer A Friend Website and Mobile App

- Functionalities
 - Enable MSUFCU Members to Refer
 - Family and Friends
 - To Become MSUFCU Members
 - Via Website and Mobile App
- Features
 - Provide Incentives To
 - Referring Member
 - New Member
 - Gear Especially to MSU Students
 - Include Social Media Sharing Function
 - Facebook
 - Twitter
 - Reflect MSUFCU Look-and-Feel and Branding
- Technologies
 - CSS, HTML, PHP, JavaScript
 - Apple iPhone and iPad (iOS) Development
 - Google Android Development
 - Microsoft SQL Server



East Lansing, Michigan

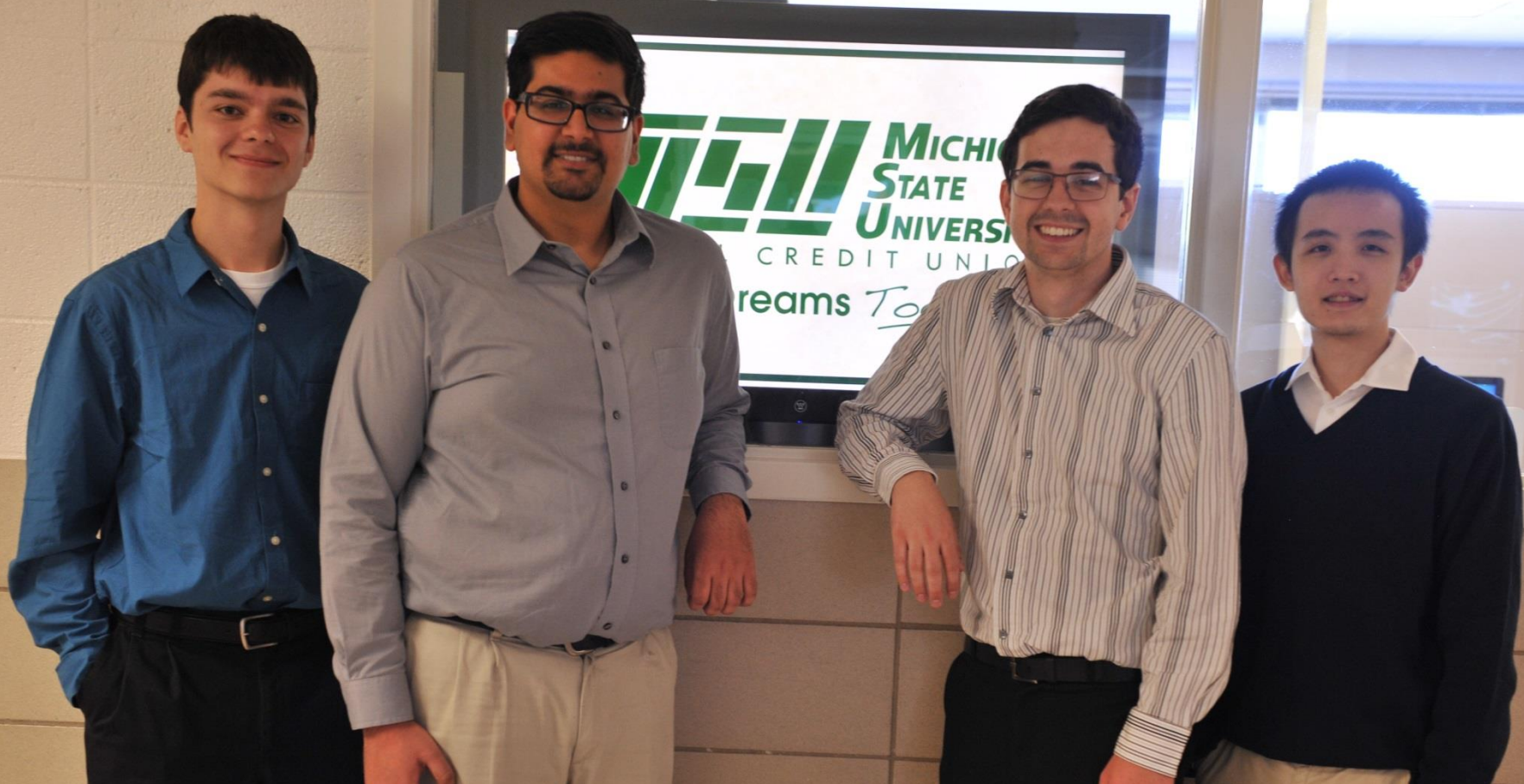

Team MSUFCU

Chris Benoit, Sahil Tandon, Josh Shadik, Yaxing Li

Team MSUFCU Project Plan Presentation

Screen Mockups



MSUFCU
MICHIGAN STATE UNIVERSITY
FEDERAL CREDIT UNION
Building Dreams *Together*



[Sign Out](#)

You earn \$50. Your friend earns \$50.

Refer a friend to create an account at MSUFCU. For any friend that creates an account after being referred, both you and your friend earn \$50.

| <u>Referrals Completed</u> | <u>Amount Earned</u> |
|----------------------------|----------------------|
| 3 | \$150 |

Share with one of these options:



MSUFCU
MICHIGAN STATE UNIVERSITY
FEDERAL CREDIT UNION
Building Dreams *Together*

You earn \$50. Your friend earns \$50.

Refer a friend to create an account at MSUFCU. For any friend that creates an account after being referred, both you and your friend earn \$50.

| <u>Referrals Completed</u> | <u>Amount Earned</u> |
|----------------------------|----------------------|
| 3 | \$150 |

Share with one of these options:





Team MSUFCU Project Plan Presentation

Team MSUFCU Project Plan Presentation

Architecture Diagram

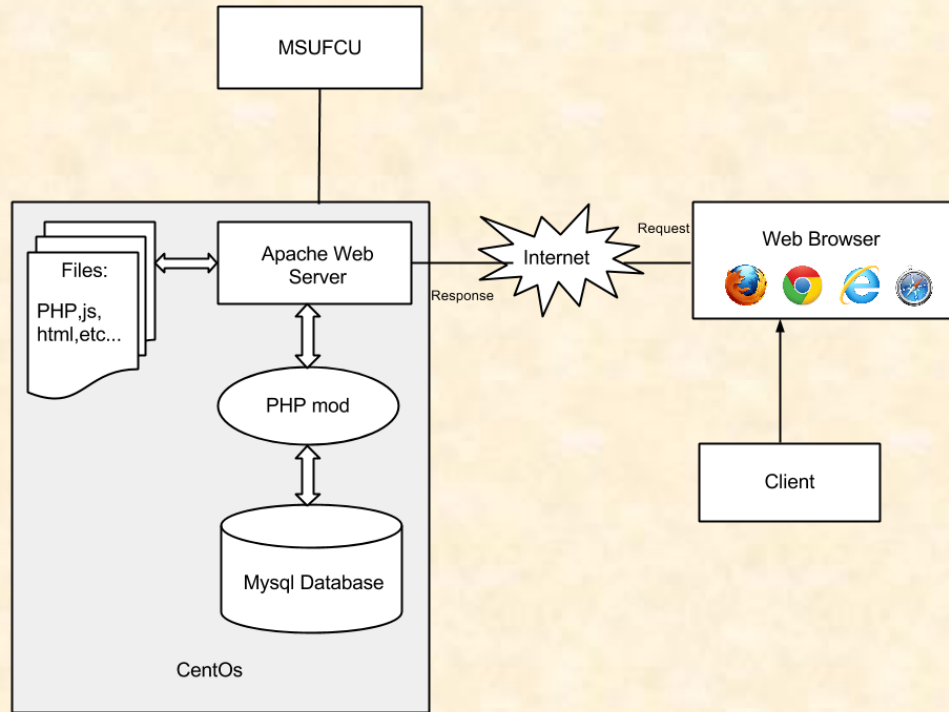

System Architecture

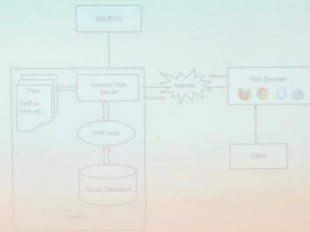

Team MSUFCU Project Plan Presentation

Screen Mockups

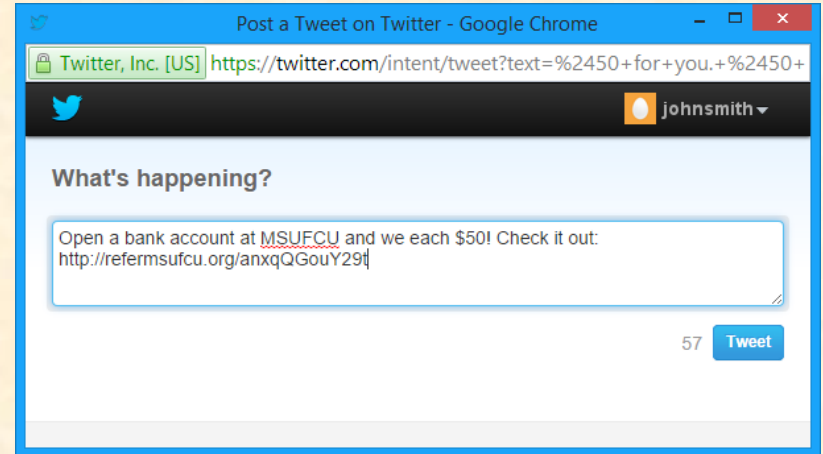
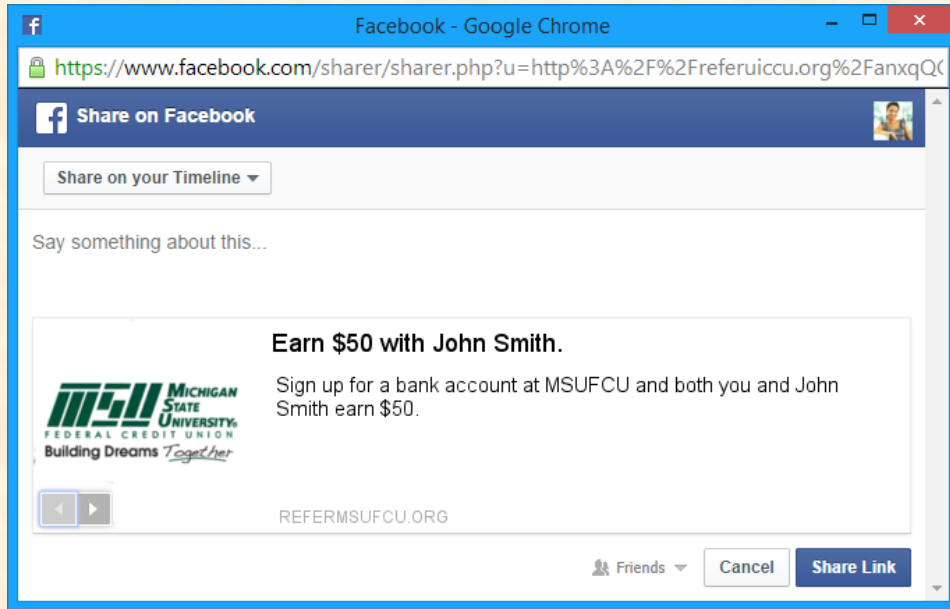



Team MSUFCU Alpha Presentation

Team MSUFCU Alpha Presentation

User Page

Team MSUFCU Refer A Friend

35.9.22.110/Main/

MSUFCU MICHIGAN STATE UNIVERSITY FEDERAL CREDIT UNION
Building Dreams Together



Log out

Information For User John Smith:



Your Refer Code:
#ref000004

You have referred:
1
person

Click the buttons below to choose how you want to share this code with friends and family.

Copyright © 2014. All Rights Reserved.



Team MSUFCU Alpha Presentation

Share Dialogs



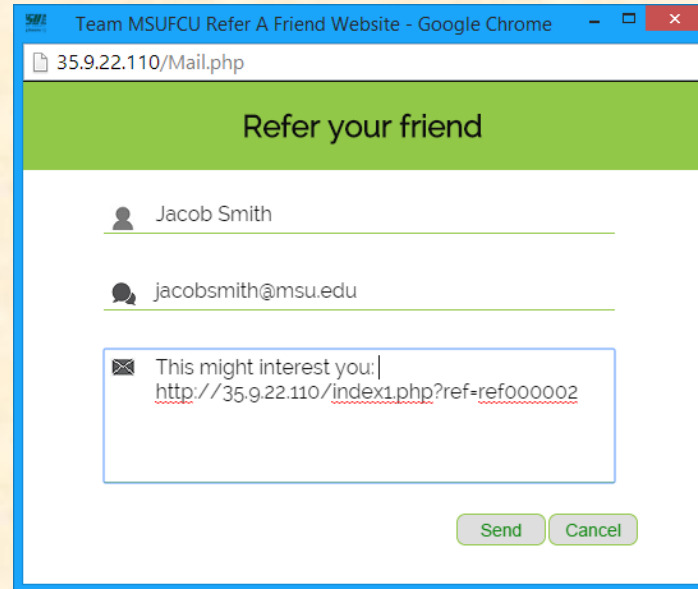
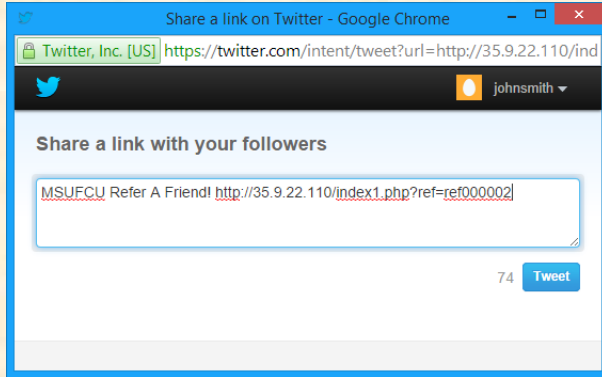

Chris Benoit has referred you to create an account at MSUFCU

When you go to sign up for a bank account at MSUFCU, use the refer code below so you can earn a \$50 bonus.

#ref000003

Click the "Print Code" button to receive a printer-friendly version of this code. You can then take this to your local MSUFCU branch.

Team MSUFCU Alpha Presentation

Team MSUFCU Alpha Presentation

Mobile User Page

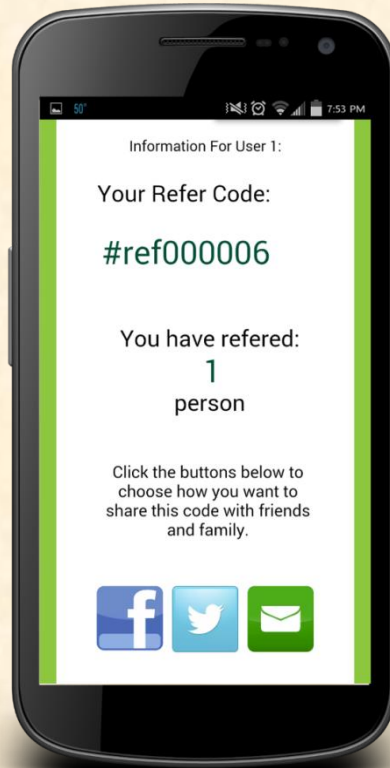



Team MSUFCU Beta Presentation

Team MSUFCU Beta Presentation

Landing Page

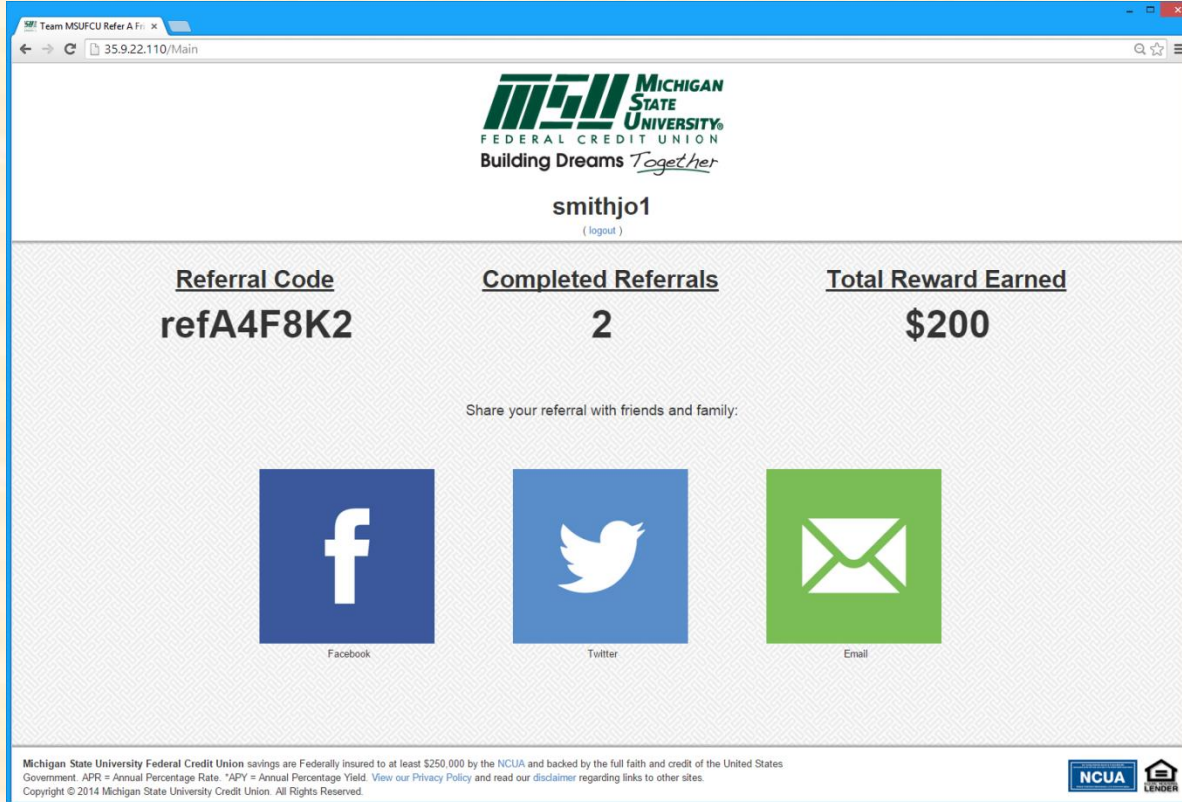

The screenshot shows a web browser window displaying the MSUFCU referral dashboard. At the top, the MSUFCU logo is visible with the tagline "Building Dreams Together". Below the logo, the user's name "smithjo1" is displayed with a "(logout)" link. The dashboard features three columns of information: "Referral Code" with the value "refA4F8K2", "Completed Referrals" with the value "2", and "Total Reward Earned" with the value "\$200". Below this information, there is a section titled "Share your referral with friends and family:" which includes three social sharing icons: Facebook, Twitter, and Email. At the bottom of the page, there is a footer with legal disclaimers and logos for NCUA and LENDER.

Team MSUFCU Refer A Friend

35.9.22.110/Main

MICHIGAN STATE UNIVERSITY
FEDERAL CREDIT UNION
Building Dreams *Together*

smithjo1
(logout)

| <u>Referral Code</u> | <u>Completed Referrals</u> | <u>Total Reward Earned</u> |
|----------------------|----------------------------|----------------------------|
| refA4F8K2 | 2 | \$200 |

Share your referral with friends and family:

Facebook Twitter Email

Michigan State University Federal Credit Union savings are Federally insured to at least \$250,000 by the NCUA and backed by the full faith and credit of the United States Government. APR = Annual Percentage Rate. *APY = Annual Percentage Yield. View our Privacy Policy and read our disclaimer regarding links to other sites.
Copyright © 2014 Michigan State University Credit Union. All Rights Reserved.

NCUA LENDER

The Capstone Experience



Team MSUFCU Beta Presentation

Management Page

The screenshot displays the MSUFCU Management Page. At the top, the MSUFCU logo is visible with the tagline "Building Dreams Together". The page features a search bar with a dropdown menu for "Username" and a search input field. Below the search bar, there are "Search" and "Clear" buttons. The search results are organized into several sections:

- User Information about username: smithjo1**

| Username | Referral code | Facebook Posts | Twitter Posts | Emails Sent | Total Posts | Total Referred | Reward earned |
|----------|---------------|----------------|---------------|-------------|-------------|----------------|---------------|
| 1 | ref000006 | 24 | 31 | 29 | 84 | 26 | 975 |
- Email Records by username: smithjo1**

| Event # | Username of Referral |
|-------------|----------------------|
| E000006HIQE | devoli@bbb.com |
| E000006G22 | asdasd |
| E000006QCAW | browserOpera |
| E000006GOAU | browserFirefox |
| E0000068UWM | browserChrome |
| E000006ZYU | browserSafari |
- Facebook Recods by username: smithjo1**

| Event # | Username of Referral |
|-------------|----------------------|
| F000006PFV7 | devoli@aaa.com |
- Twitter Recods by username: smithjo1**

| Event # | Username of Referral |
|-------------|----------------------|
| T000006D8QC | devoli@ccc.com |
| T000006W9Q | aaa@devoli.com |

At the bottom of the page, a footer states: "Michigan State University Federal Credit Union savings are Federally insured to at least \$250,000 by the NCUA and backed by the full faith and credit of the United States Government."





Team MSUFCU Beta Presentation

Team MSUFCU Beta Presentation

Mobile App

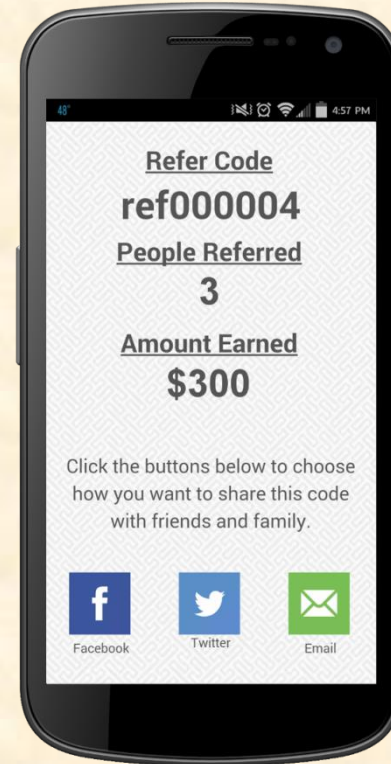
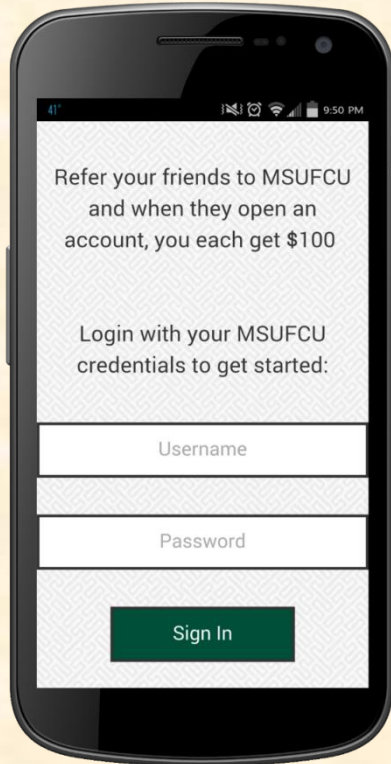



Team MSUFCU
Design Day

MICHIGAN STATE
UNIVERSITY

The Capstone Experience

Team Quicken Loans

Department of Computer Science and Engineering
Michigan State University

Fall 2014



*From Students...
...to Professionals*

Quicken[®] Loans[®]

Engineered to **AmazeSM**

Quicken Loans
Engineered to **Amaze**

Need help? [Chat](#) or Call **(800) 251-9080**



[Home](#) | [Refinance](#) | [Buy a House](#) | [Loan Options](#) | [Mortgage Rates](#) | [Calculators](#) | [About Us](#) | **ZING!** [Blog](#)

You Could Close Your Loan **IN 30 DAYS!**

Get started, and get saving

Refinance

Buy a Home



Team Quicken Loans Project Overview

Enterprise Architecture Visualizer

- Functionalities
 - Model and Display Visual Dependency Map
 - Of Quicken Loans' Enterprise Architecture
 - Including All Major Applications
- Features
 - Provide
 - Web-Based App
 - Drag-and-Drop Capabilities for All Assets
 - Include
 - Server Names
 - Database Names
 - Teams that Support Applications
 - Support Future States
- Technologies
 - CSS, HTML, JavaScript
 - Microsoft Internet Information Services (IIS)
 - Microsoft C#
 - SQL Server 2005 and Higher

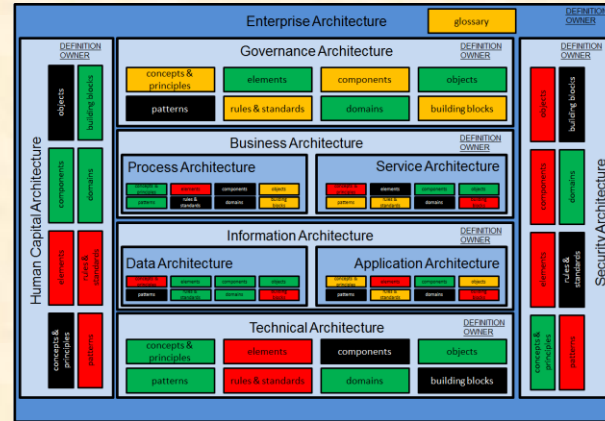

Quicken Loans
Engineered to **Amaze**[™]
Detroit, Michigan

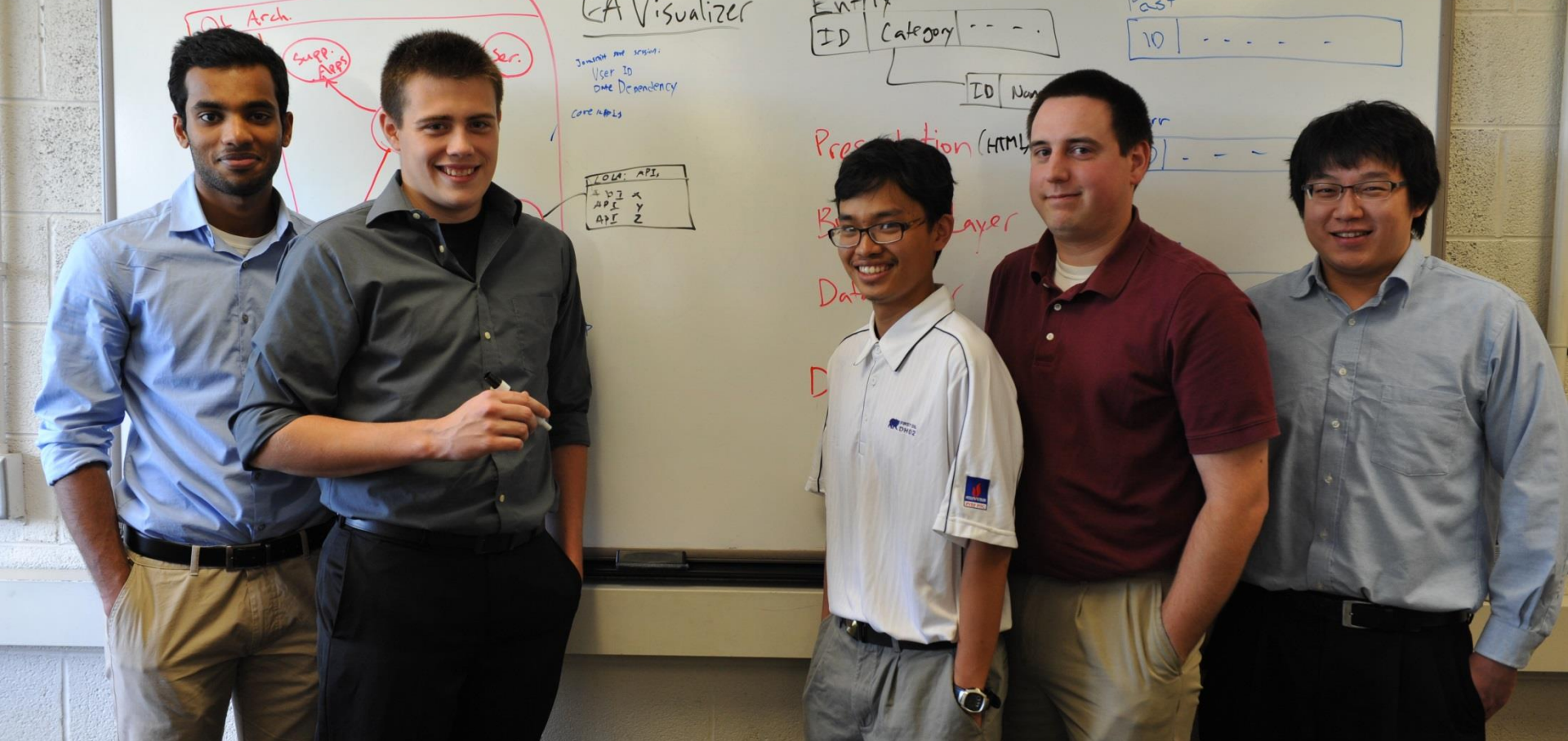

Team Quicken Loans

Ari Polavarapu, Jeff Johnson, Minh Pham, Garret Smith, Steve Choo

Team Quicken Loans Project Plan Presentation

Screen Mockup

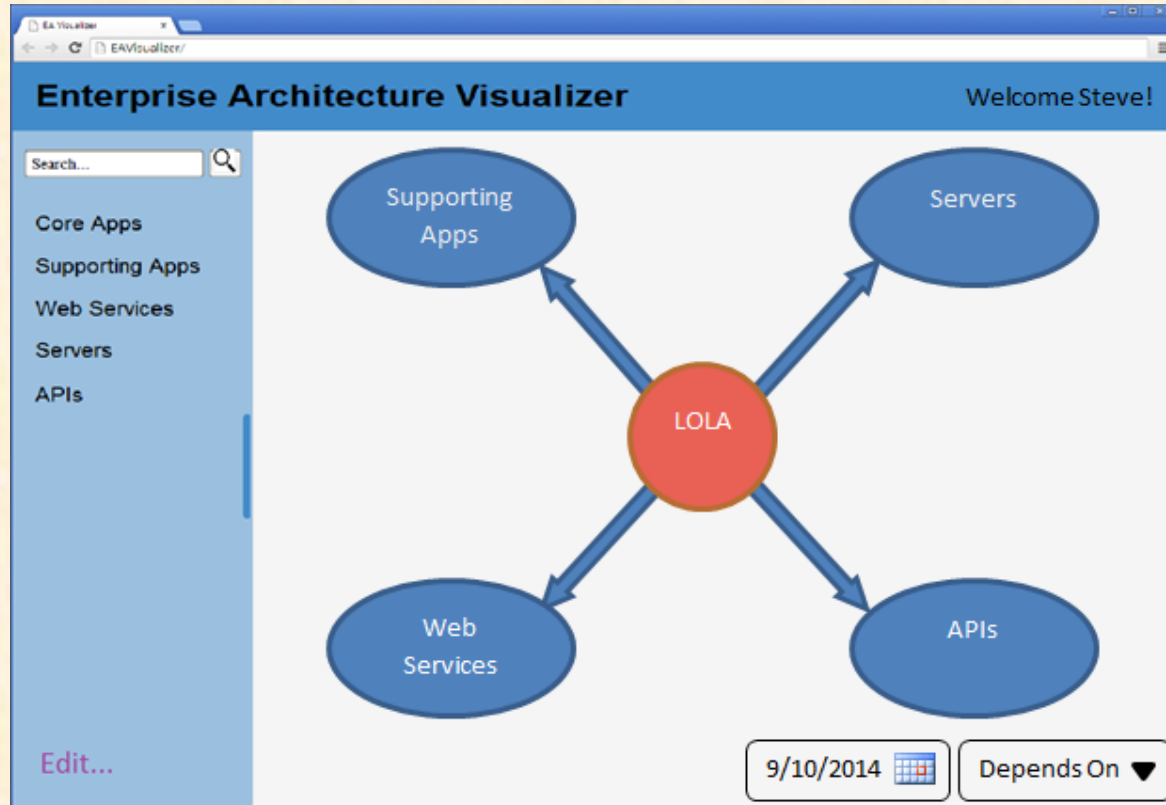

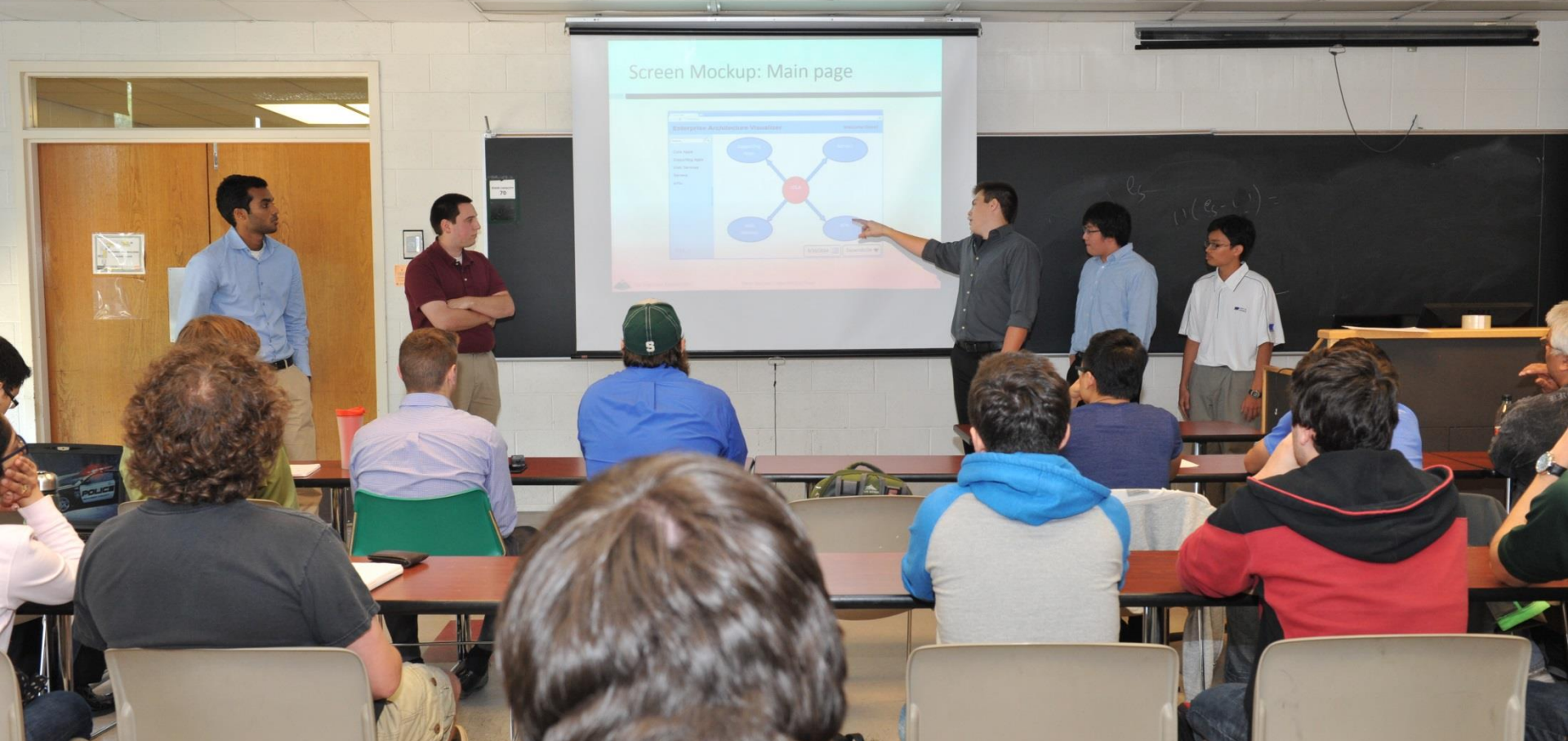

Team Quicken Loans Project Plan Presentation

Team Quicken Loans Project Plan Presentation

Architecture Diagram

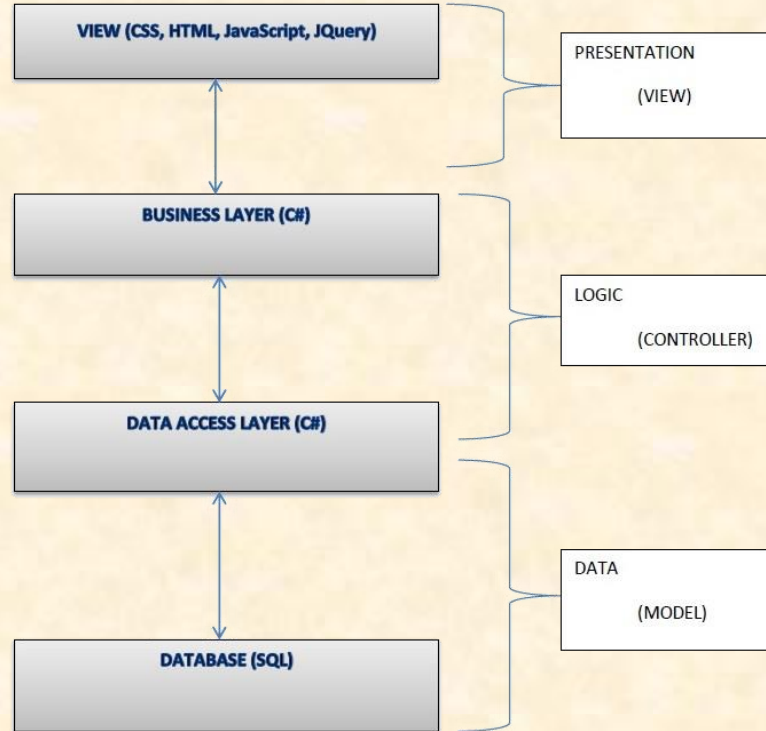



System Architecture

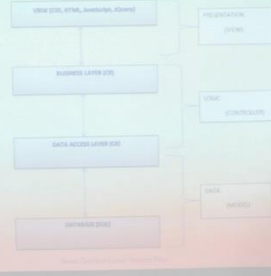

Team Quicken Loans
Project Plan Presentation

Team Quicken Loans Project Plan Presentation

Screen Mockup

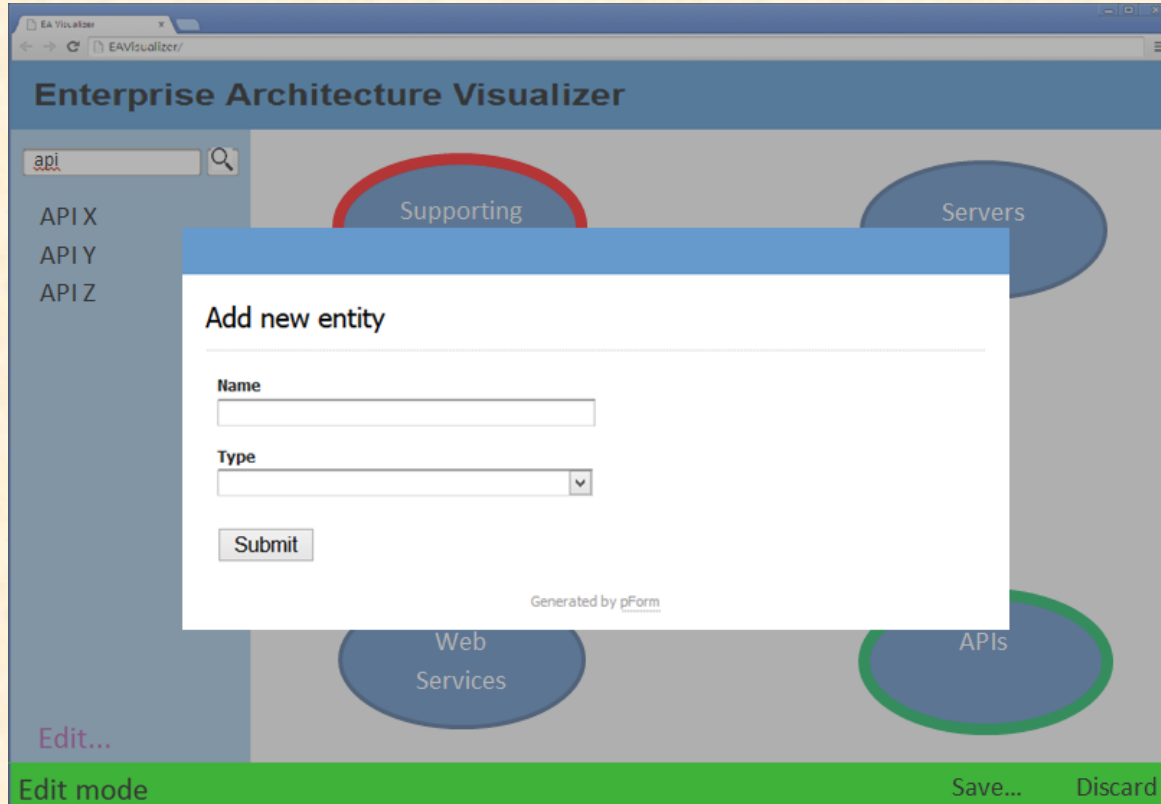



Team Quicken Loans Alpha Presentation

Team Quicken Loans Alpha Presentation

Initial App Screen

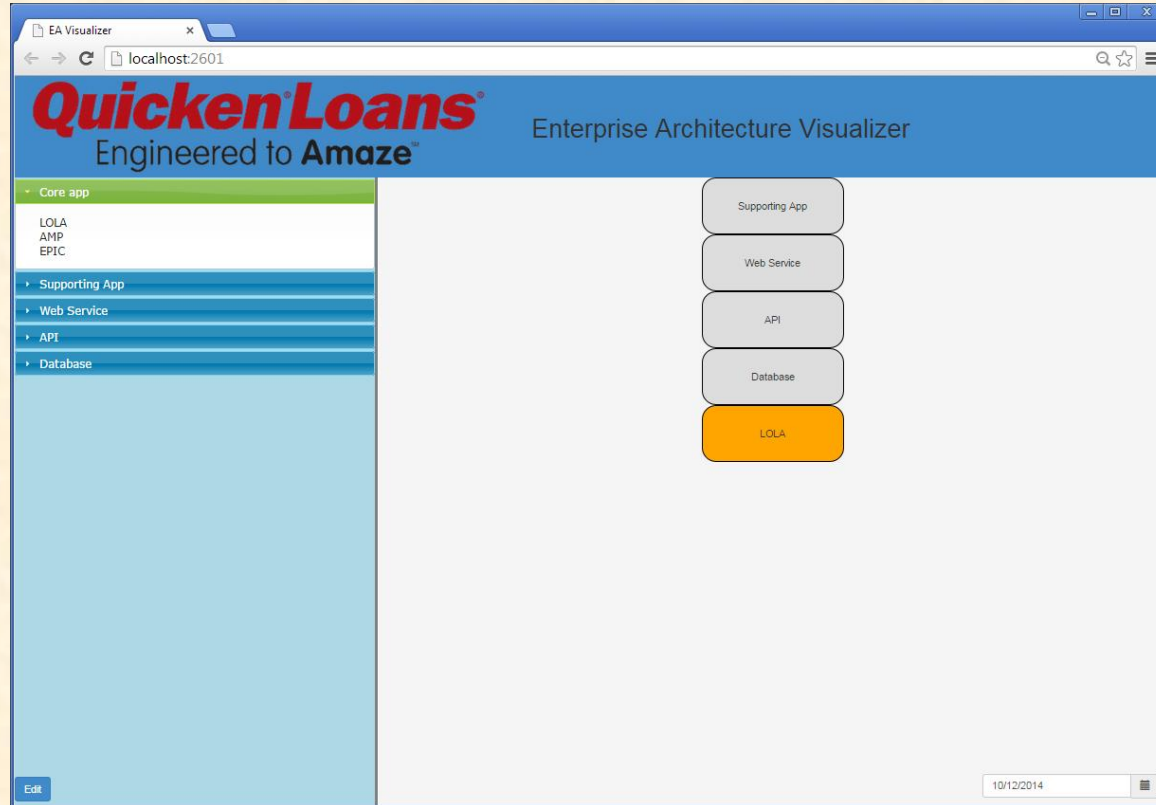

Team Quicken Loans Alpha Presentation

Editing Entities

Add Entity X

Entity Name:

Entity Category:
Core app ▼

Effective Date:
10/12/2014 📅

End Date:
10/12/2014 📅

Close Save changes

Delete Entity X

Entity Name:
LOLA ▼

Close Delete Entity





What's left to do?

- User Interface Enhancements
- Drag And Drop Feature
- Search Bar
- Displaying Past And Future States
- Potential Active Directory Connection

Team Quicken Loans
Alpha Presentation

Team Quicken Loans Alpha Presentation

Editing Dependencies

Add Dependency X

Entity:
LOLA ▼

Dependency Entity:
LOLA ▼

Effective Date:
10/12/2014 

End Date:
10/12/2014 

Close Save changes

API X

API1 

API2 

Close Save changes





Team Quicken Loans Beta Presentation

Team Quicken Loans Beta Presentation

Expanded Dependencies

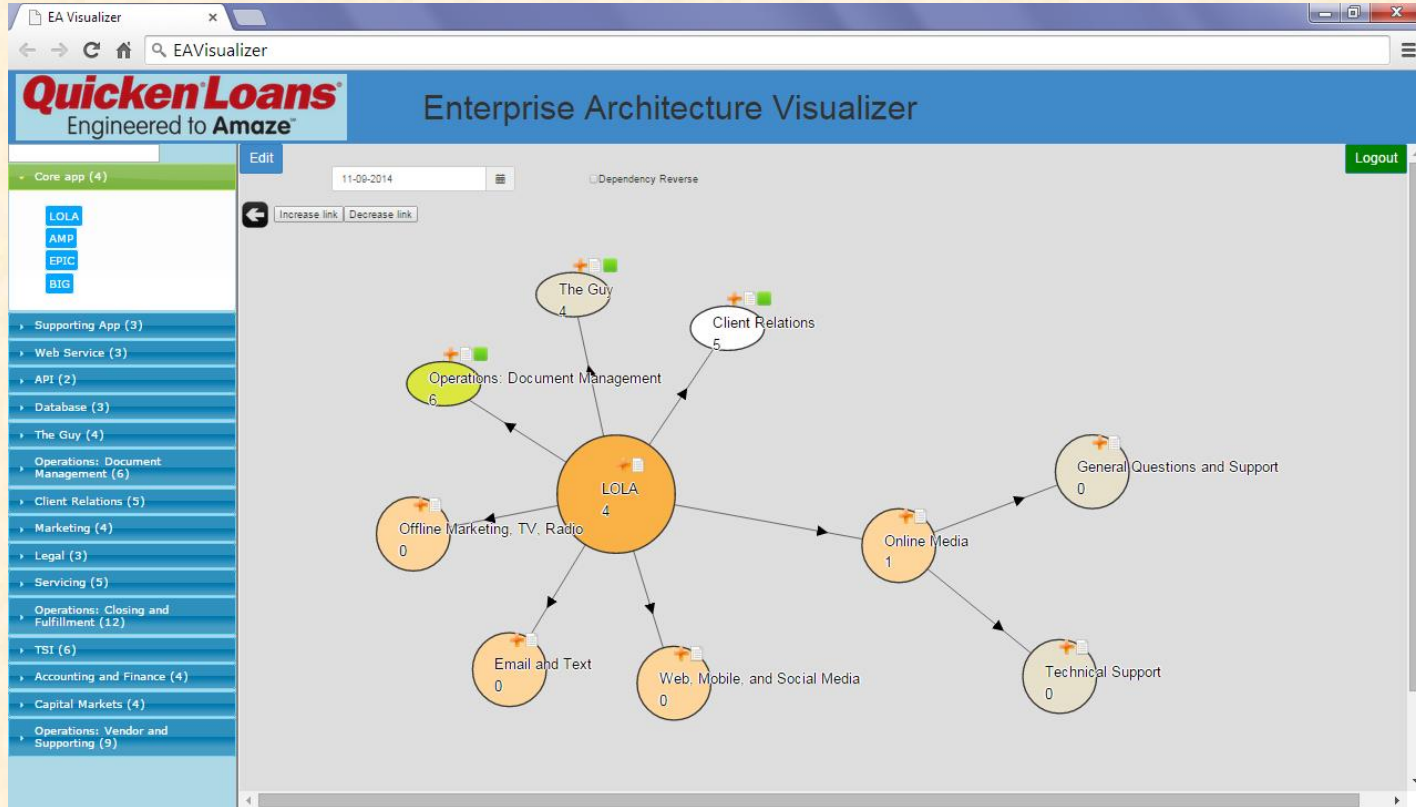

Team Quicken Loans Beta Presentation

Live Search



Search results for 'L' (before filtering):

- Core app (4)
 - LOLA
 - AMP
 - EPIC
 - BIG
- Supporting App (3)
- Web Service (3)
- API (2)
- Database (3)
- The Guy (4)
 - General Questions and Support
 - Technical Support
 - 411 jobs
 - Loan Support
- Operations: Document Management (6)
- Client Relations (5)
- Marketing (4)
- Legal (3)
- Servicing (5)
- Operations: Closing and Fulfillment (12)
- TSI (6)
- Accounting and Finance (4)
- Capital Markets (4)

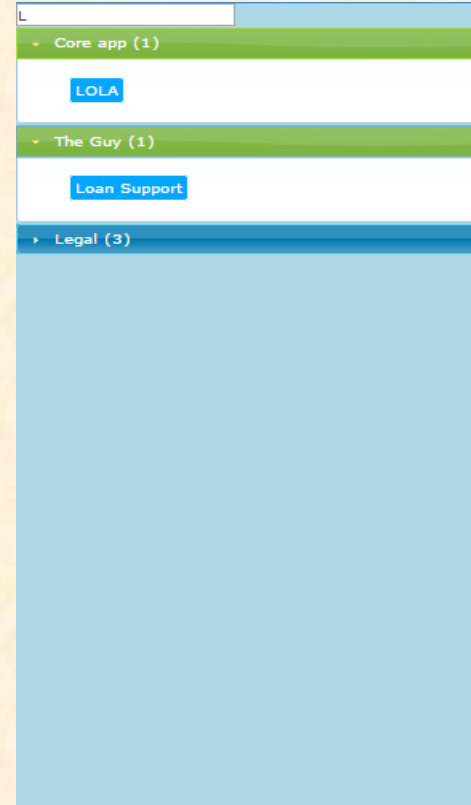
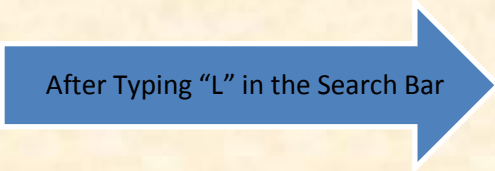

Search results for 'L' (after filtering):

- Core app (1)
 - LOLA
- The Guy (1)
 - Loan Support
- Legal (3)



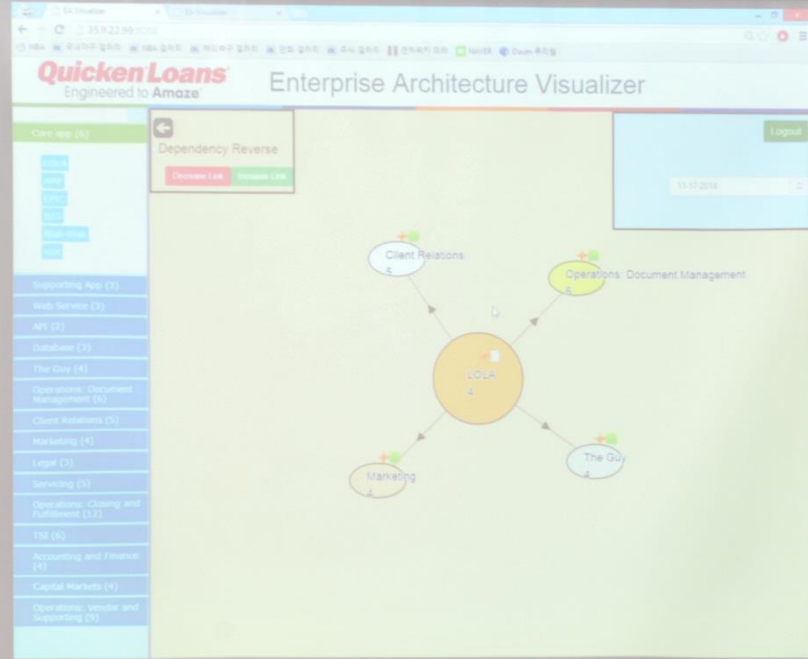

Team Quicken Loans Beta Presentation

Team Quicken Loans Beta Presentation

Snapshots by Date

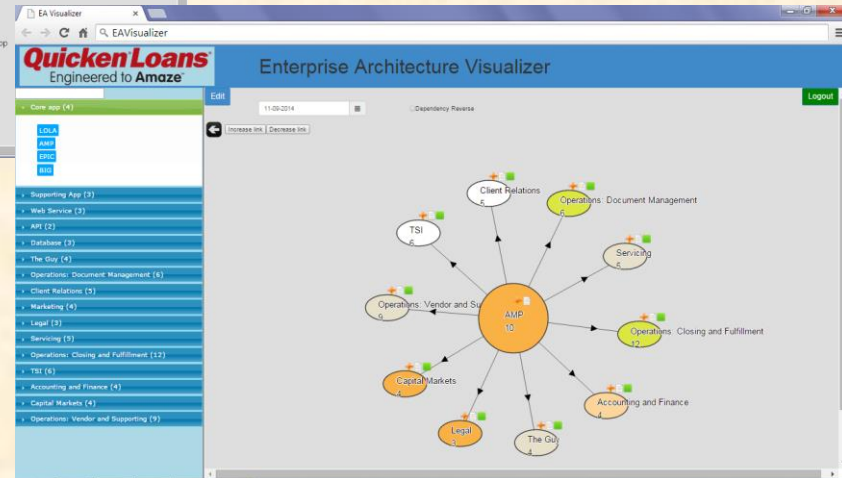
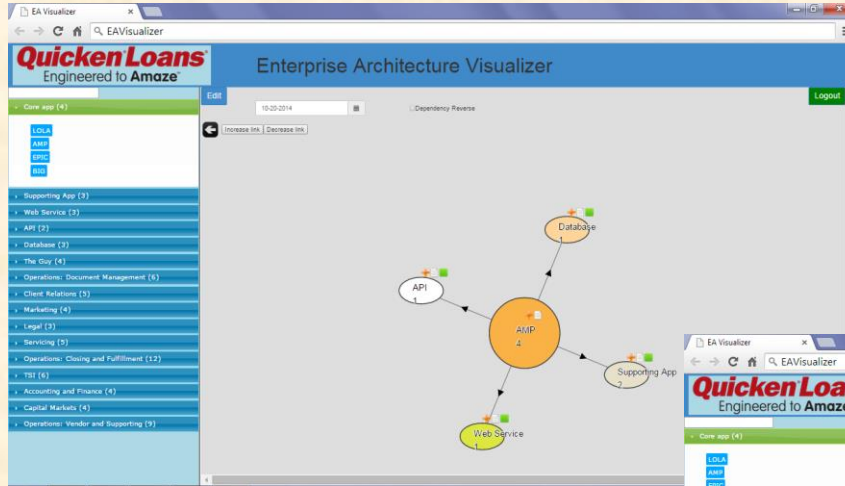



Team Quicken Loans
Design Day

MICHIGAN STATE

UNIVERSITY

The Capstone Experience

Team Spectrum Health

Department of Computer Science and Engineering
Michigan State University

Fall 2014



*From Students...
...to Professionals*

SPECTRUM HEALTH





Search input field with magnifying glass icon

Advanced Search

- Home icon
- Who We Are
- Patients & Visitors
- Medical Services
- Quality
- Locations
- Online Services
- Health Information
- Find a Physician



Visit Our Blogs

Keep up with the latest health information, expert advice, recipes, and more!

MySpectrum™

User Name:

Password:

> [Forgot User Name](#) [Forgot Password](#) [Log In](#)

[Enroll Now](#) > [Learn More](#)

Locations

Select Type of Location

[Gandalf's Gala 2](#)

[Doctor Dialogue](#)

[Visit Our Blogs](#)

Team Spectrum Health Project Overview

Employee Discount Mobile App

- Functionalities
 - Provide Access to Employee Discounts
 - For Spectrum Health Employees
 - Via Mobile App
- Features
 - Support Apple iPhone and Google Android
 - Handle Frequent Changes and Updates
 - Include Additional Discounts for Priority Health Employees
- Technologies
 - CSS, HTML5, JavaScript
 - AngularJS
 - ASP.net MVC
 - Microsoft Internet Information Services (IIS) 7.0
 - RESTful Web Service Layer

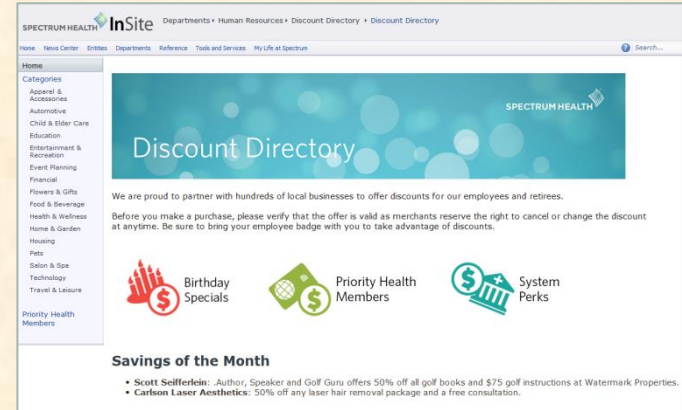

SPECTRUM HEALTH

Grand Rapids, Michigan



Team Spectrum Health

Aries Xue, Ruchira Ramani, Marco Botros, Emily Van Norman, Josh Pelcher

Team Spectrum Health Project Plan Presentation

Screen Mockup

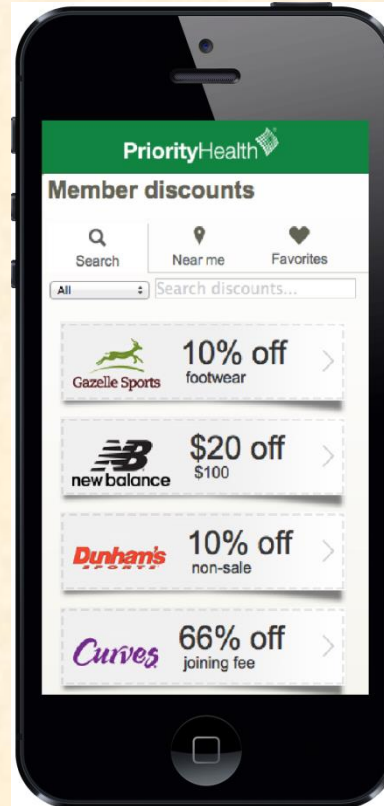



Team Spectrum Health
Project Plan Presentation

Team Spectrum Health Project Plan Presentation

Architecture Diagram

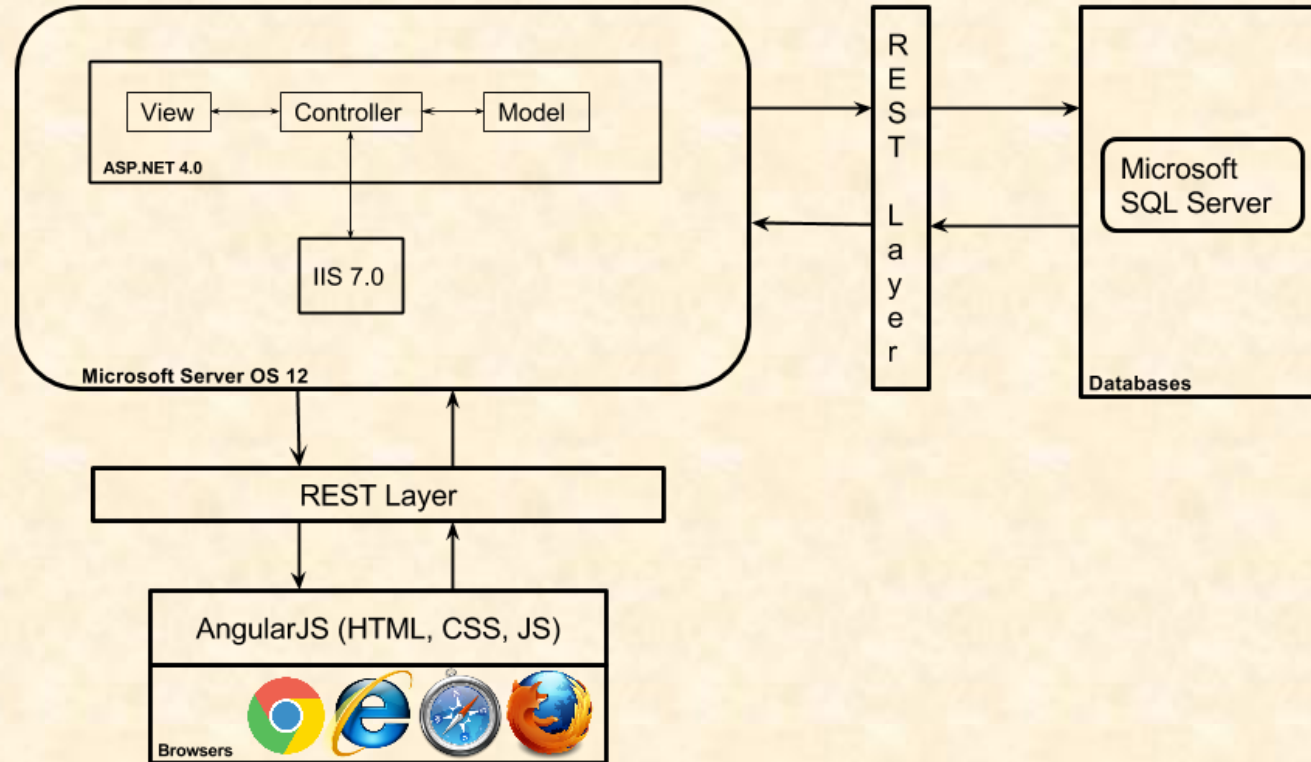



Team Spectrum Health
Project Plan Presentation

Team Spectrum Health Project Plan Presentation

Screen Mockup

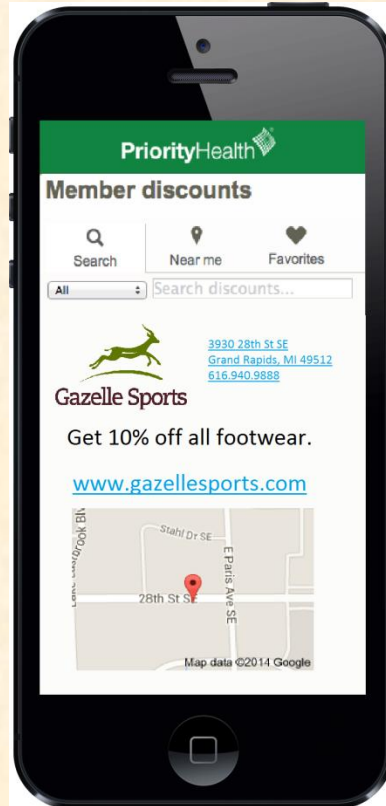



Team Spectrum Health
Alpha Presentation

Team Spectrum Health Alpha Presentation

Landing Page

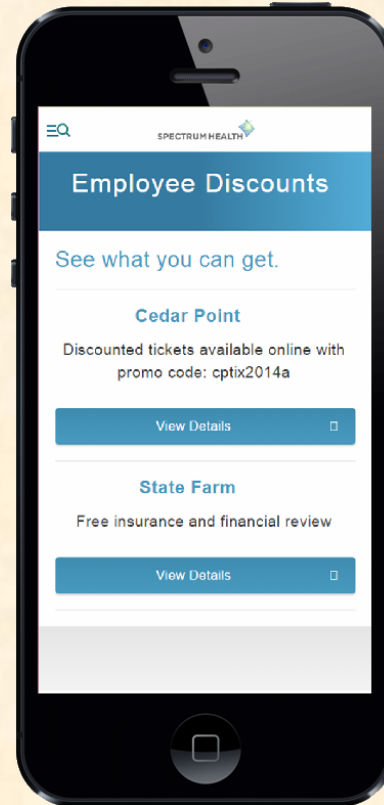

The Capstone Experience



Team Spectrum Health Alpha Presentation

Category Selection

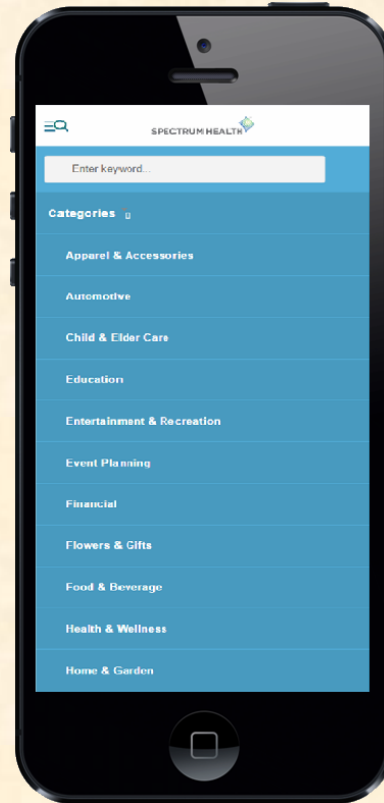

The Capstone Experience





Team Spectrum Health Alpha Presentation

Team Spectrum Health Alpha Presentation

Promotion Details

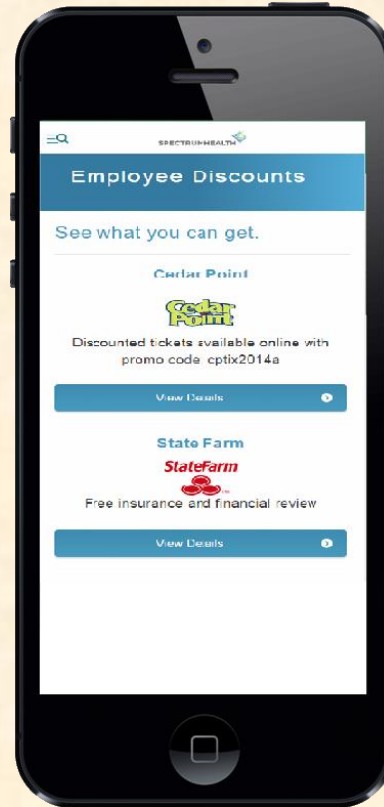

The Capstone Experience





Team Spectrum Health Beta Presentation

Team Spectrum Health Beta Presentation

Phone View of App

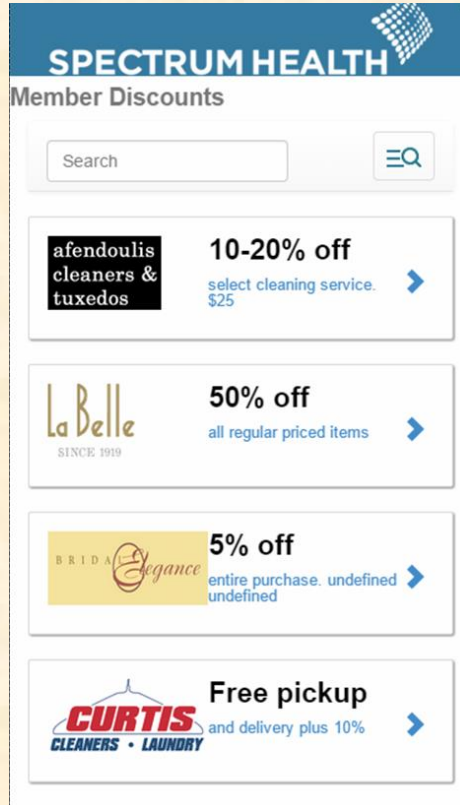



SPECTRUM HEALTH

Member Discounts

Search 

afendoulis cleaners & tuxedos **10-20% off**
select cleaning service. \$25 

LaBelle **50% off**
SINCE 1919 all regular priced items 

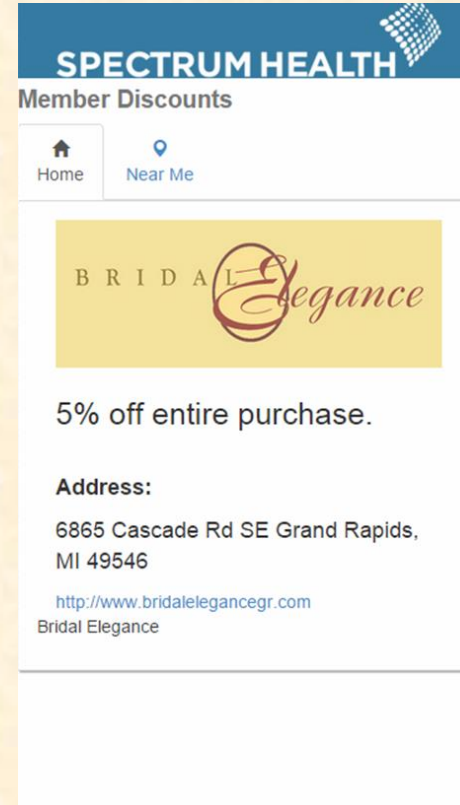

BRIDAL Elegance **5% off**
entire purchase. undefined 

CURTIS CLEANERS • LAUNDRY **Free pickup**
and delivery plus 10% 



SPECTRUM HEALTH

Member Discounts

 Home  Near Me

BRIDAL Elegance

5% off entire purchase.

Address:
6865 Cascade Rd SE Grand Rapids,
MI 49546
<http://www.bridalelegancegr.com>
Bridal Elegance

Team Spectrum Health Beta Presentation

Tablet View of App

SPECTRUM HEALTH

Member Discounts

Search

Home Near Me Categories Sort By

- afendoulis cleaners & tuxedos** 10-20% off
select cleaning service. \$25
- La Belle** 50% off
all regular priced items
- BRIDA Elegance** 5% off
entire purchase. undefined
- CURTIS CLEANERS • LAUNDRY** Free pickup
and delivery plus 10%
- dp** 10% off,
free gift wrapping and
- Free conversion**
logo to embroidery file
- Handme** 15% off
regular priced shoes. undefined
- JOS. A. BANK** 20% off
regular priced items (excludes
- Lee&Birch** 10% off
entire purchase plus free
- LEIGH'S** Free gift
wrapping, rush alterations and





Team Spectrum Health
Beta Presentation

Team Spectrum Health Beta Presentation

Near Me and Map Features

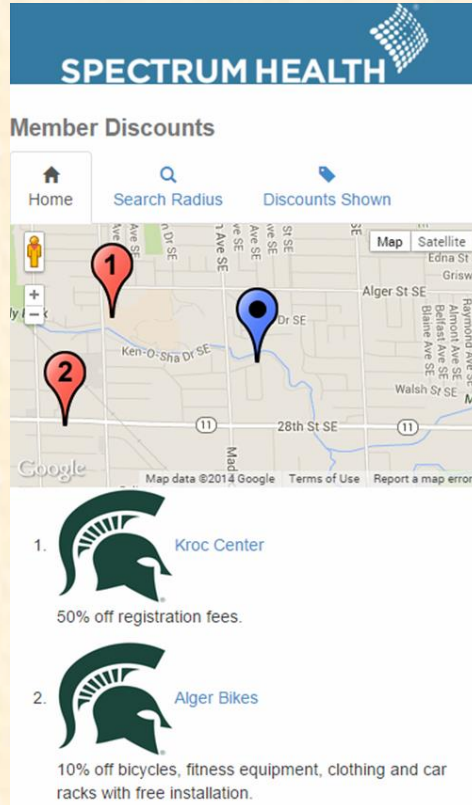

SPECTRUM HEALTH

Member Discounts

Home Search Radius Discounts Shown

1.  **Kroc Center**
50% off registration fees.

2.  **Alger Bikes**
10% off bicycles, fitness equipment, clothing and car racks with free installation.

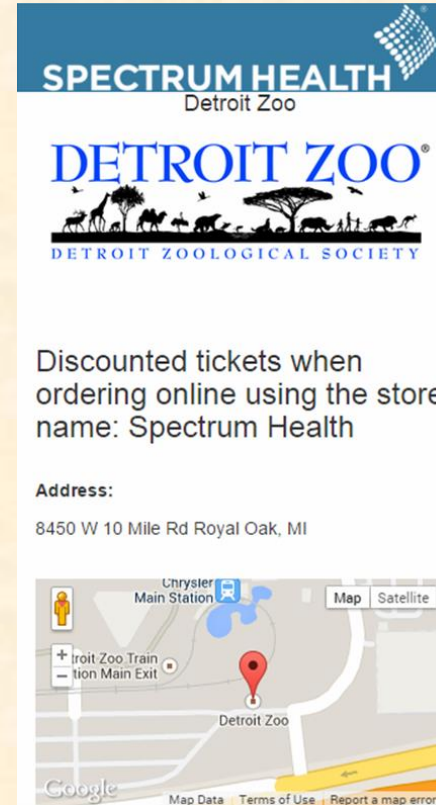

SPECTRUM HEALTH
Detroit Zoo

DETROIT ZOO
DETROIT ZOOLOGICAL SOCIETY

Discounted tickets when ordering online using the store name: Spectrum Health

Address:
8450 W 10 Mile Rd Royal Oak, MI

Chrysler Main Station
Detroit Zoo Train Station Main Exit
Detroit Zoo



Team Spectrum Health
Design Day

MICHIGAN STATE

UNIVERSITY

The Capstone Experience

Team TechSmith

Department of Computer Science and Engineering
Michigan State University

Fall 2014



*From Students...
...to Professionals*



TechSmith®



Helping you work, wherever you are

TechSmith helps you solve everyday problems with ease. Whether you're trying to explain something over email or keep your students' attention, TechSmith can help you work faster and smarter.



WATCH NOW

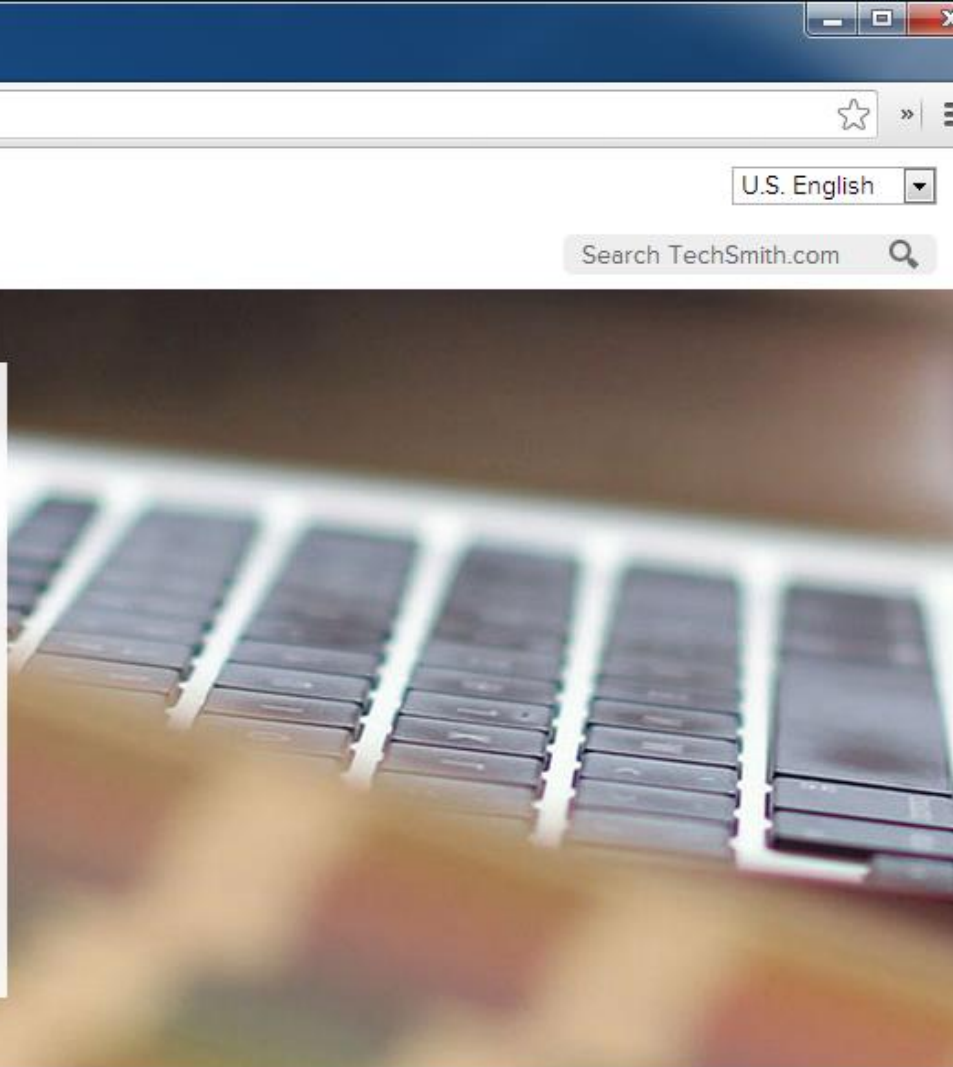

Team TechSmith Project Overview

Groupwork for Google Chrome

- Functionalities
 - Facilitate Group Activities and Projects
 - Using Content Created or Collected with Snagit for Chrome
 - Via a Google Chrome App
- Features
 - Create and Maintain Groups
 - Maintain Activities and Projects
 - Create
 - Assign Tasks and Roles
 - Facilitate Parts
 - Track Progress
 - Provide Various Views
 - My Groups
 - My Projects
 - A Project
 - Support Several Project Types
 - Integrate Seamlessly
 - With Snagit for Chrome
 - With Google Docs and Google Drive
 - Instrument with Google Analytics
- Technologies
 - HTML5, CSS, JavaScript
 - Google App APIs
 - Google Drive SDK
 - Google Analytics



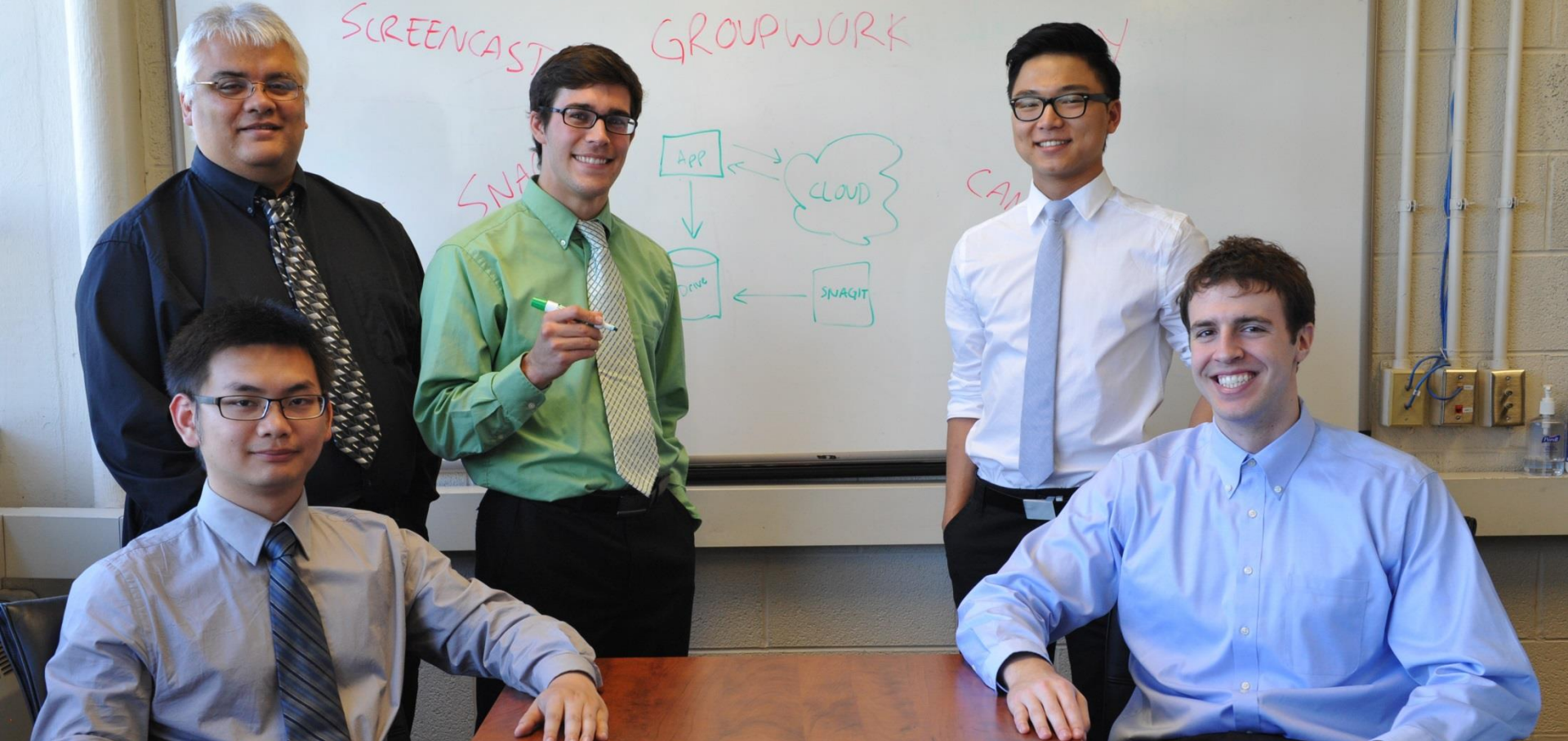

Team TechSmith

Ryan Chen, Gerald Kizer, Justin Fila, Spencer Yi, Christian Fincher

Team TechSmith Project Plan Presentation

Screen Mockup

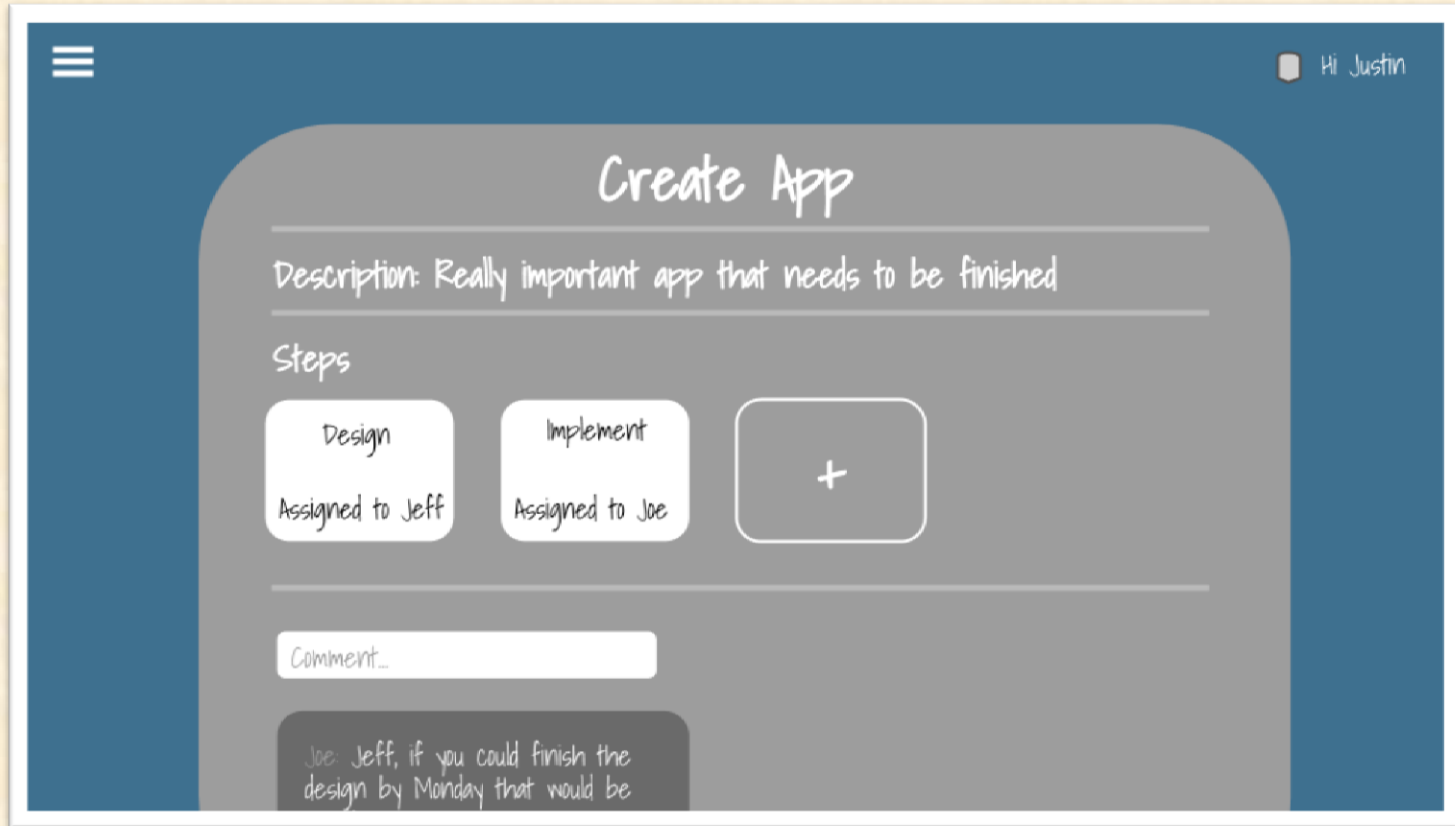



Team TechSmith
Project Plan Presentation

Team TechSmith Project Plan Presentation

Architecture Diagram

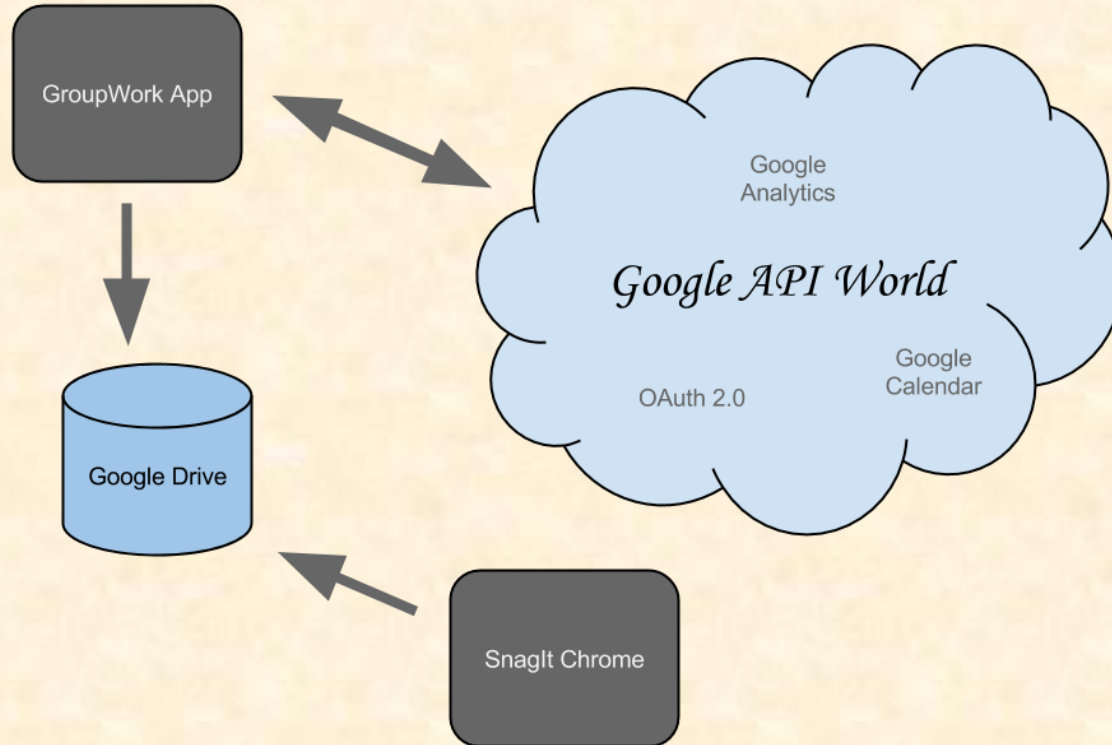

Technical Specifications

Other Google APIs

- OAuth 2.0
- Drive
- Analytics

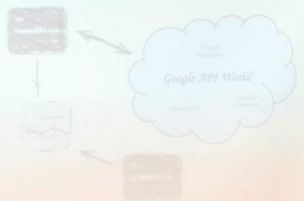

Team TechSmith Project Plan Presentation

Screen Mockup





Team TechSmith Alpha Presentation

Team TechSmith Alpha Presentation

Landing Page

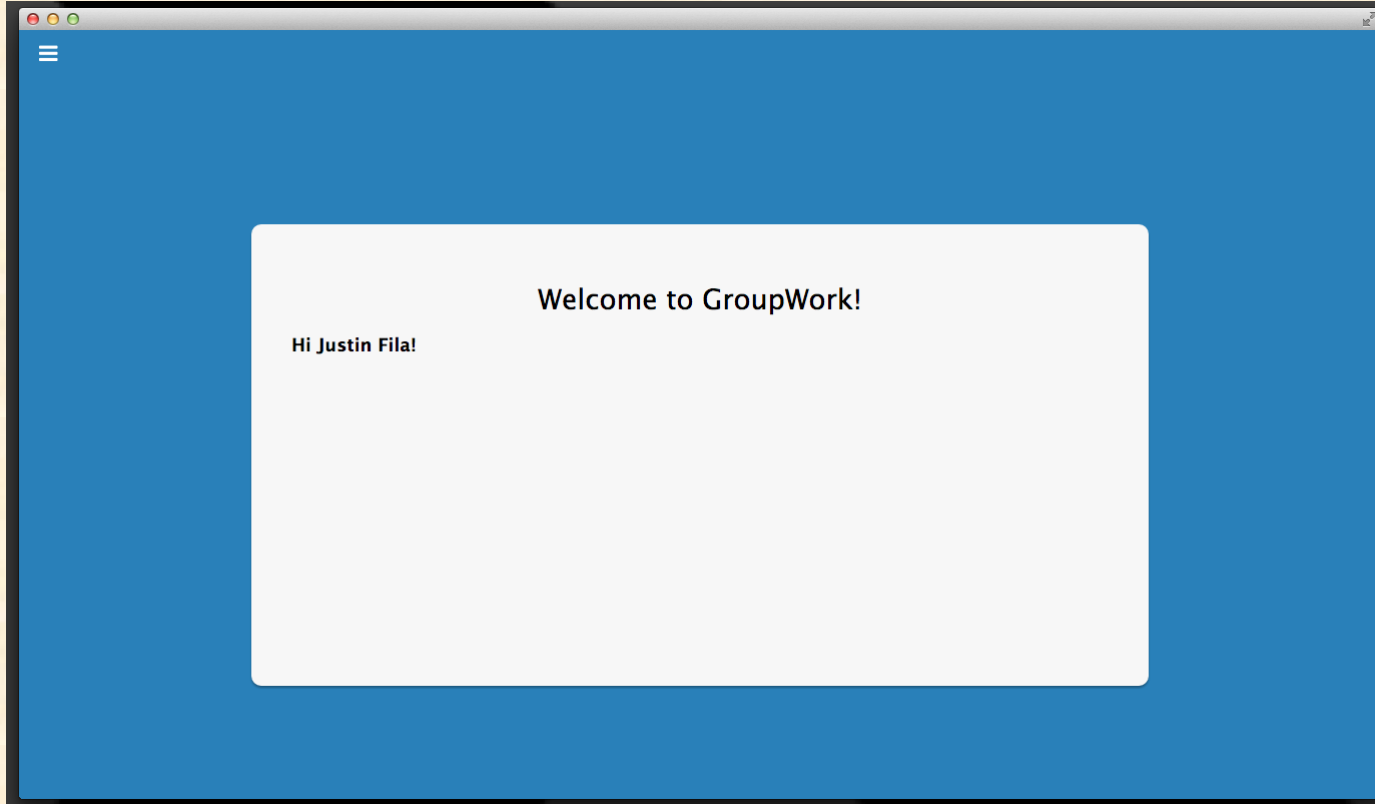

Team TechSmith Alpha Presentation

My Groups

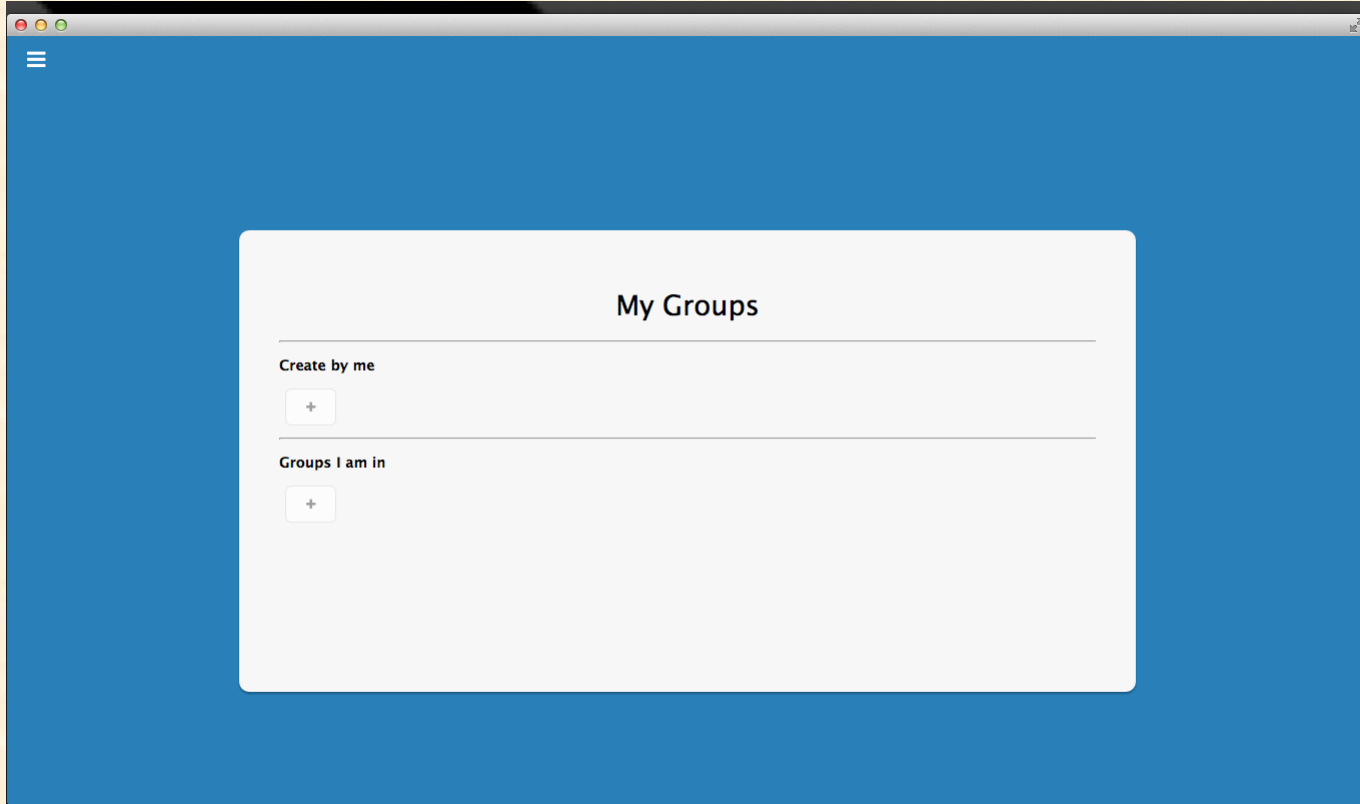



Team TechSmith Alpha Presentation

Team TechSmith Alpha Presentation

My Projects

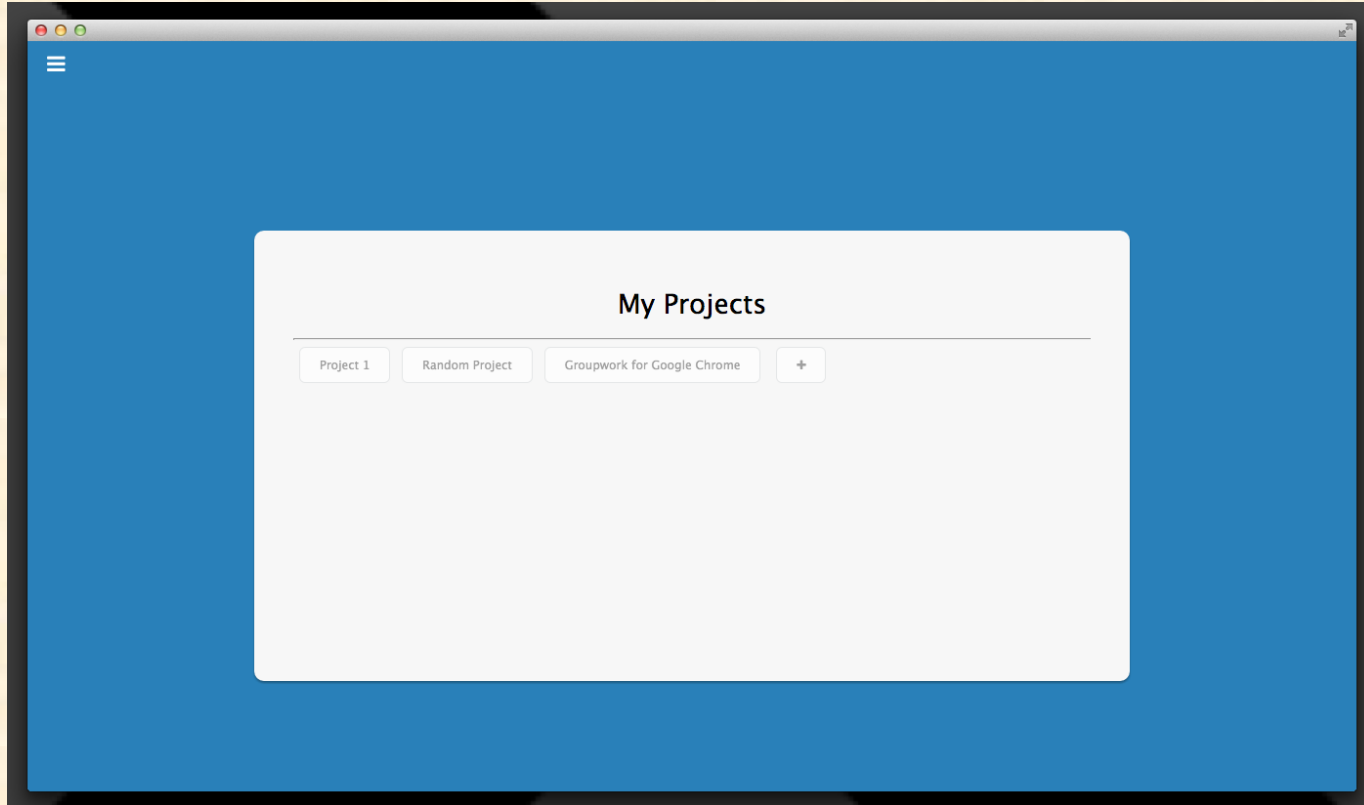

The Capstone Experience





Team TechSmith Beta Presentation

Team TechSmith Beta Presentation

Group View

The screenshot shows a web interface for viewing a group. At the top left, there is a hamburger menu icon and the text "View Group". At the top right, there is a user profile icon labeled "GKizer .". The main content area is titled "Capstone Group" with a pencil icon for editing. Below this is "CSE 498 group" with another pencil icon. A section titled "Group members:" contains three member avatars: Justin Fila, Spencer Yi, and Christian Fincher. To the right of these is a blue circle with a white plus sign and the text "Add New Member". Below the avatars, the word "Projects" is visible. Three red arrows point from a box labeled "Current members" to the three member avatars. Two red arrows point from a box labeled "Edit group here" to the pencil icons next to "Capstone Group" and "CSE 498 group". One red arrow points from a box labeled "Click to add more members" to the plus sign icon.



Team TechSmith Beta Presentation

Project View

The screenshot displays the 'View Project' interface for 'GroupWork For Chrome'. At the top left, there is a hamburger menu icon and the text 'View Project'. At the top right, there is a user profile icon labeled 'GKizer .'. The main content area is divided into two sections: 'Assigned Groups' and 'Steps'.
The 'Assigned Groups' section features a button labeled 'Capstone Group' with a plus sign to its right. A callout box with the text 'Assign group to this project' has an arrow pointing to the plus sign.
The 'Steps' section is organized into three columns: 'Start', 'Beta Tasks', and 'Video'.
- The 'Start' column contains 'UML Diagram' and 'Architecture' buttons.
- The 'Beta Tasks' column contains a 'Presentation' button and a plus sign. A callout box with the text 'Add/remove tasks here' has three arrows pointing to the 'Presentation' button, the plus sign, and the bottom of the column.
- The 'Video' column contains 'Create Script' and 'Record Video' buttons.
A plus sign is located to the right of the 'Video' column. A callout box with the text 'Add another step' has an arrow pointing to this plus sign.
A callout box with the text 'Click to view the state of this group's project' has an arrow pointing to the 'Capstone Group' button.





Team TechSmith Beta Presentation

Team TechSmith Beta Presentation

Navigation Bar

The screenshot displays a web application interface with a dark blue header and a light blue sidebar. The sidebar contains the following navigation items: Home, My Groups, Create Group, My Projects, and New Project. The main content area has a dark blue header with the text "GroupWork For Chrome" and "Capstone Group". Below this, there is a section titled "Steps" with three columns: "Start" (containing "UML Diagram" and "Architecture"), "Beta Tasks" (containing "Presentation"), and "Video" (containing "Create Script" and "Record Video"). A callout box with a red arrow points to the "Create Group" item in the sidebar, containing the text "Navigate to other pages here".



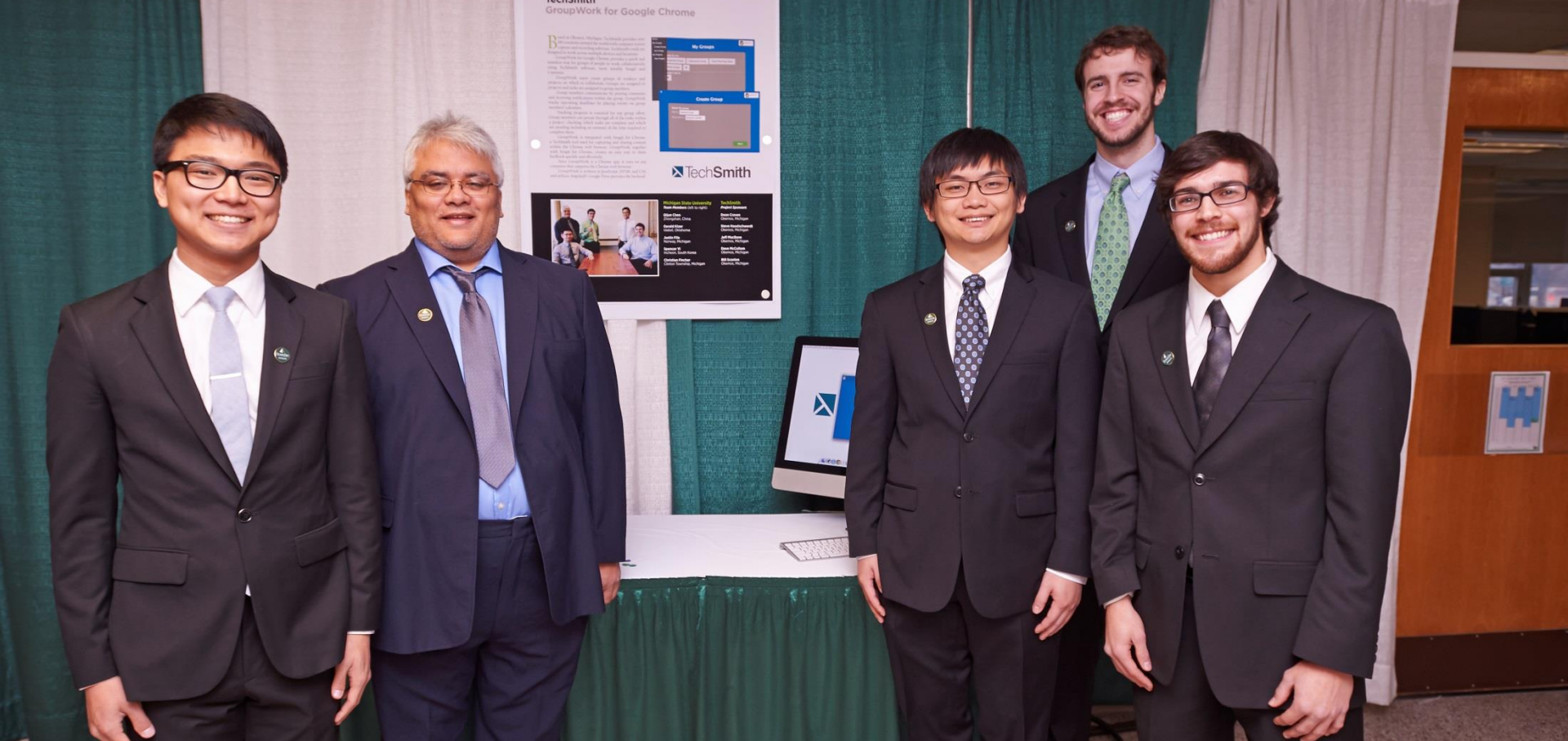

Team TechSmith
Design Day

MICHIGAN STATE
UNIVERSITY

The Capstone Experience

Team Urban Science

Department of Computer Science and Engineering
Michigan State University
Fall 2014



*From Students...
...to Professionals*

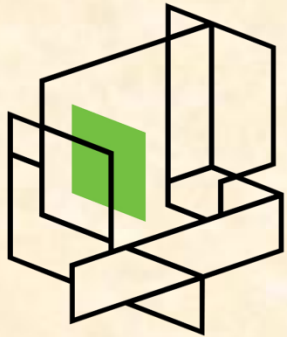

URBAN SCIENCE™



Develop Dealer Network

Improve Dealer Performance

Manage Leads

Optimize Marketing

The Power of 4™



THE POWER OF 4™



Team Urban Science Project Overview

HR Matters

- Functionalities
 - Enable Assessment of Behavioral Competencies
 - Of Automobile Dealership Employees
 - By Dealership Managers
- Features
 - Provide Evaluation Tool Based on Standards
 - Model Behavioral Competencies
 - For Use During Interviews
 - Assess Candidate's Ability to Perform a Role
 - Track Historical Employee Performance
 - Correlate Behavioral Competencies with Actual Results
 - Display Metrics for Original Equipment Manufacturers (OEMs)
- Technologies
 - CSS, HTML, JavaScript
 - Apple iPad (iOS) Development
 - SQL Server 2012
 - Model-View-Controller Architecture
 - Responsive Design



URBAN SCIENCE.
Detroit, Michigan



Team Urban Science

Jenna Cyrocki, Brandon Sartele, Kenny Massie, Michael Nelson

Team Urban Science Project Plan Presentation

Screen Mockup





Team Urban Science Project Plan Presentation

Team Urban Science Project Plan Presentation

Architecture Diagram

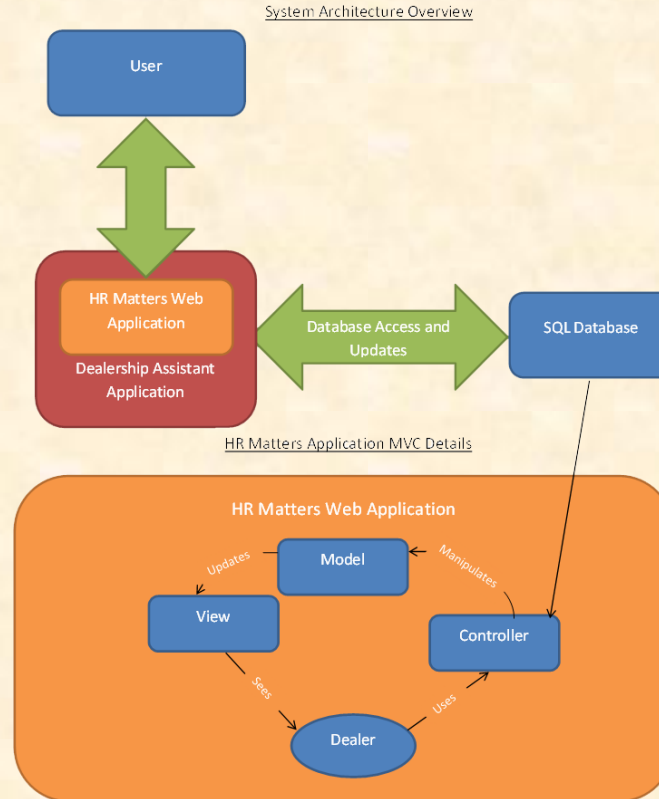



Team Urban Science
Project Plan Presentation

Team Urban Science Project Plan Presentation

Screen Mockup

The screen mockup displays a user profile for Luigi Visalli and a list of competency assessment results. The profile includes a photo, name, last score (29/60), and contact information. The assessment results are listed in a table with categories and last scores. A detailed description for the 'CUSTOMER SERVICE ORIENTATION' category is provided.

COMPETENCY SMARTS
powered by **URBAN SCIENCE**

UNIVERSAL MOTORS

SEARCHING FOR WORK TRENDS

Competency Assessment Full Results

| | |
|---------------------------------------|---------------|
| VERBAL COMMUNICATION | LAST SCORE: 1 |
| RESULTS ORIENTATION | LAST SCORE: 4 |
| CONCERN FOR ORDER, QUALITY & ACCURACY | LAST SCORE: 1 |
| INTERPERSONAL UNDERSTANDING | LAST SCORE: 1 |
| CUSTOMER SERVICE ORIENTATION | LAST SCORE: 1 |
| SELF-CONTROL | LAST SCORE: 3 |
| SELF-CONFIDENCE | LAST SCORE: 4 |
| FLEXIBILITY / ADAPTABILITY | LAST SCORE: 5 |
| RELATIONSHIP BUILDING | LAST SCORE: 2 |
| ASSERTIVENESS | LAST SCORE: 3 |
| DEVELOPING OTHERS | LAST SCORE: 1 |
| NEGOTIATION | LAST SCORE: 3 |

LUIGI VISALLI

29/60
LAST SCORE

EMPLOYEE ID: 111111
visalli@urbanscience.com
MAFIA MOTORS

Hire Date: 06/21/94
Position: Sales Manager
Direct Manager: AlPacino
HR Manager: Robert DeNiro
Current Location: Secret Warehouse
School: Borgata University
Degree: Masters in Waste Management
Languages: English/Italian

[DOWNLOAD RESUME](#)

Conduct a preliminary assessment to determine if the sales manager is capable of having a genuine desire to help customers (internal and external). If this capability does not exist, termination should occur immediately as it is a poor job fit. If the capability to exhibit customer service orientation does exist, immediately place on a performance improvement plan targeting the behaviors for improvement. Immediate improvement within 30 days would need to be observed. If no immediate improvement after 30 days, termination would occur.

Conduct a preliminary assessment to determine if the sales manager is capable of effectively coaching sales staff (is there any prior history of effective coaching tactics used in the past). If this capability does not exist, demotion and/or termination should occur immediately as it is a poor job fit. If the capability to effectively coach/mentor does exist, immediately place on a performance improvement plan targeting the behaviors for improvement. Immediate improvement within 30 days would need to be observed. If no immediate improvement after 30 days, demotion and/or termination would occur.





Team Urban Science Alpha Presentation

Team Urban Science Alpha Presentation

Dashboard

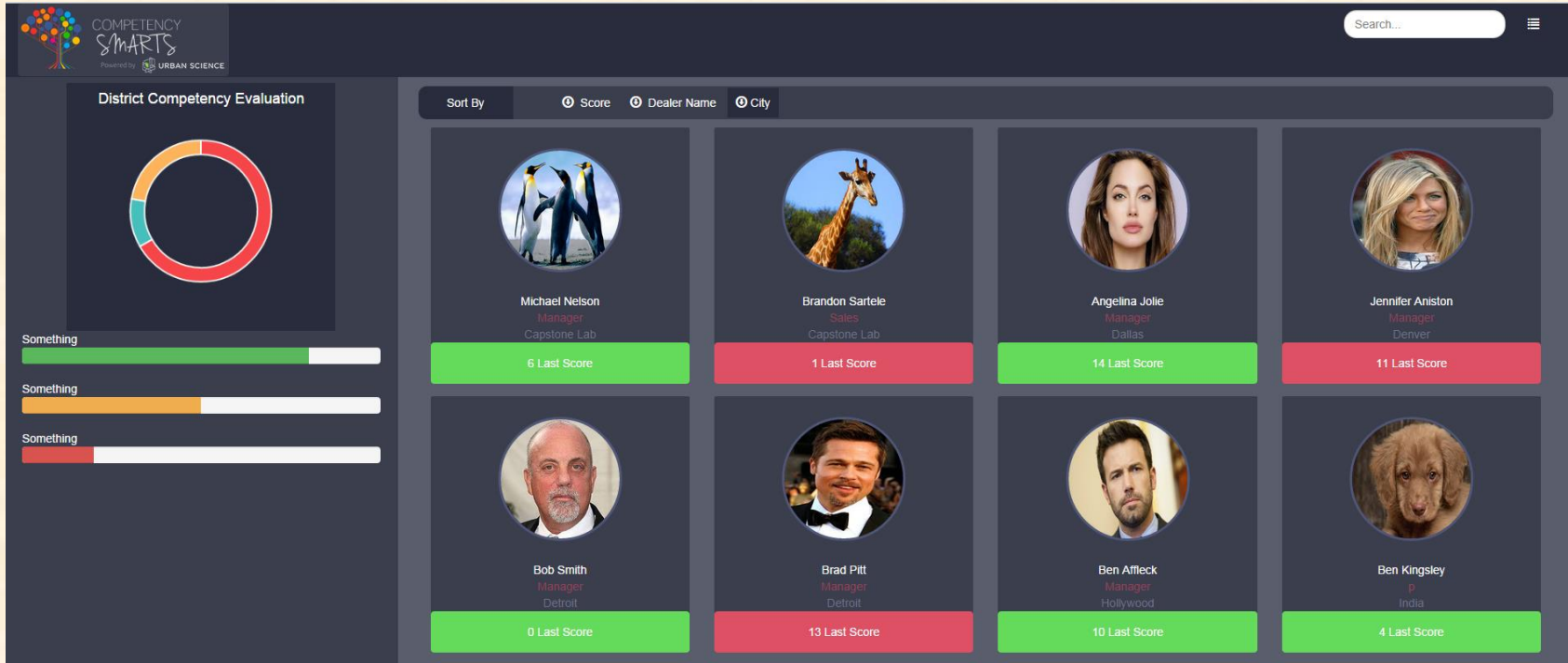

Team Urban Science Alpha Presentation

Competency Assessment Chart





Team Urban Science Alpha Presentation

Team Urban Science Alpha Presentation

Full Assessment Results



COMPETENCY SMARTS
Powered by URBAN SCIENCE



Bob Smith

Last Score

EMPLOYEE ID: 1234253235
someemail@gmail.com
[Employee dealership here](#)

Hire Date: 9/23/2014
Position: **Manager**
Current Location: **Detroit**
School: **Michigan State**
Degree: **Bachelors**

Competency Assessment Full Results

| | |
|---|---------------|
| <input type="radio"/> CUSTOMER SERVICE ORIENTATION | Last Score: 7 |
| Conduct a preliminary assessment to determine if the sales manager is capable of having a genuine desire to help customers (internal and external). If this capability does not exist, termination should occur immediately as it is a poor job fit. If the capability to exhibit customer service orientation does exist, immediately place on a performance improvement plan targeting the behaviors for improvement. Immediate improvement within 30 days would need to be observed. If no immediate improvement after 30 days, termination would occur. | |
| <input type="radio"/> VERBAL COMMUNICATION | Last Score: 7 |
| <input type="radio"/> RESULTS ORIENTATION | Last Score: 7 |
| <input type="radio"/> CONCERN FOR QUALITY | Last Score: 7 |
| <input type="radio"/> INTERPERSONAL UNDERSTANDING | Last Score: 7 |
| <input type="radio"/> SELF-CONTROL | Last Score: 7 |
| <input type="radio"/> SELF-CONFIDENCE | Last Score: 7 |
| <input type="radio"/> FLEXIBILITY / ADAPTIBILITY | Last Score: 7 |
| <input type="radio"/> RELATIONSHIP BUILDING | Last Score: 7 |
| <input type="radio"/> ASSERTIVENESS | Last Score: 7 |
| <input type="radio"/> DEVELOPING OTHERS | Last Score: 7 |
| <input type="radio"/> NEGOTIATION | Last Score: 7 |





Team Urban Science Beta Presentation

Team Urban Science Beta Presentation

Assessment Chart

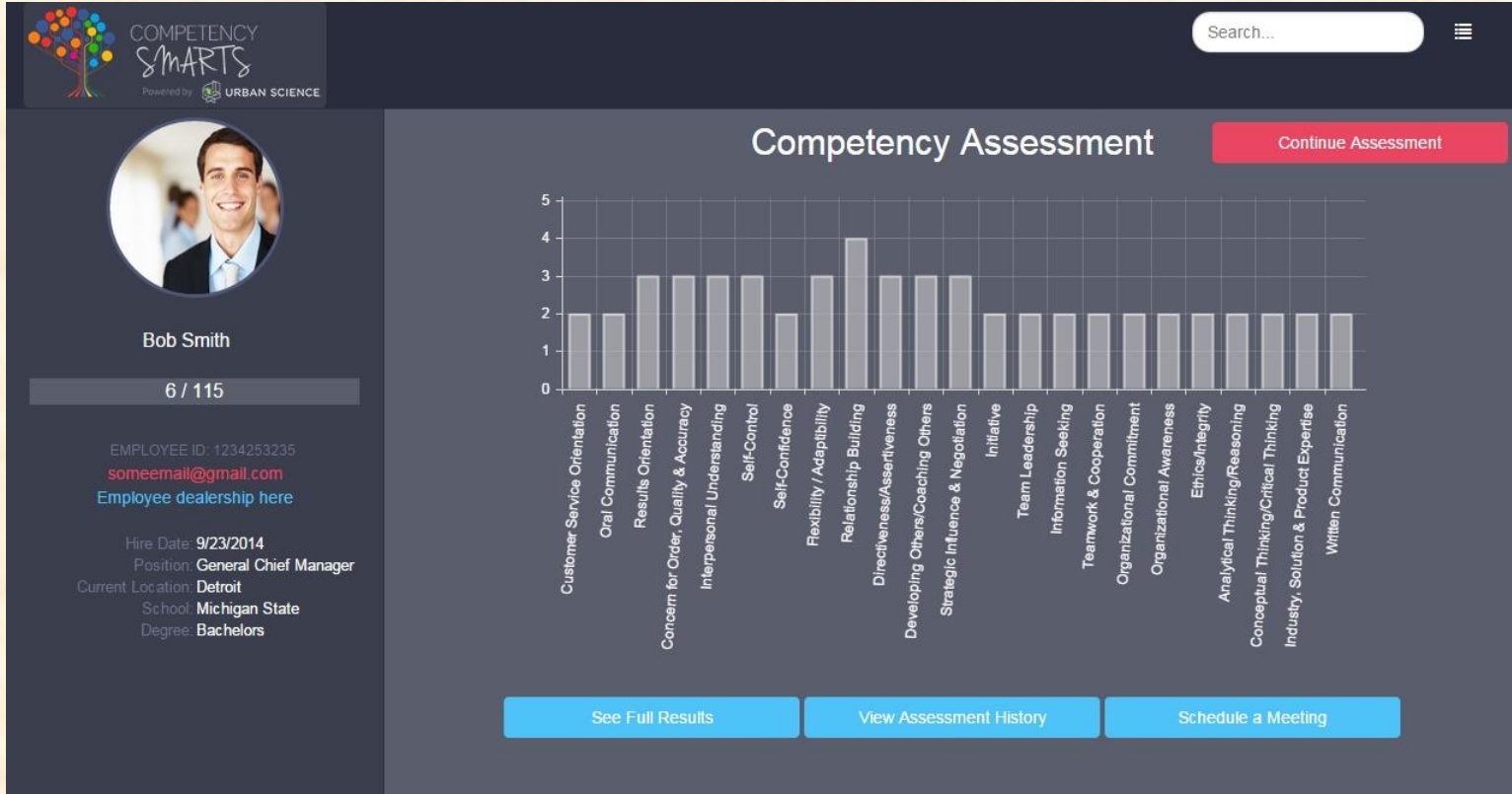

Team Urban Science Beta Presentation

Competency Chart





Team Urban Science Beta Presentation

Team Urban Science Beta Presentation

Assessment Full Results



COMPETENCY SMARTS
Powered by URBAN SCIENCE



Bob Smith

6 / 115

EMPLOYEE ID: 1234253235
someemail@gmail.com
[Employee dealership here](#)

Hire Date: 9/23/2014
Position: General Chief Manager
Current Location: Detroit
School: Michigan State
Degree: Bachelors

Competency Assessment Full Results

| | |
|---|---------------|
| CUSTOMER SERVICE ORIENTATION | Last Score: 2 |
| ORAL COMMUNICATION | Last Score: 2 |
| RESULTS ORIENTATION | Last Score: 3 |
| An individual's concern with working well to achieve optimal results and/or for competing against a standard of excellence. This includes an individual's responsibility for timeliness, commitment to task and adherence to performance standards. | |
| CONCERN FOR ORDER, QUALITY & ACCURACY | Last Score: 3 |
| INTERPERSONAL UNDERSTANDING | Last Score: 3 |
| SELF-CONTROL | Last Score: 3 |
| SELF-CONFIDENCE | Last Score: 2 |
| FLEXIBILITY / ADAPTIBILITY | Last Score: 3 |
| RELATIONSHIP BUILDING | Last Score: 4 |
| DIRECTIVENESS/ASSERTIVENESS | Last Score: 3 |
| DEVELOPING OTHERS/COACHING OTHERS | Last Score: 3 |



Team Urban Science
Design Day

MICHIGAN STATE
UNIVERSITY

The Capstone Experience

Team Whirlpool

Department of Computer Science and Engineering
Michigan State University
Fall 2014



*From Students...
...to Professionals*



Whirlpool

CORPORATION





LAUNDRY

KITCHEN

HOME SOLUTIONS

FILTERS & ACCESSORIES

SERVICE & SUPPORT



True innovation takes the complexity out.

The Whirlpool Dishwasher uses Sensor Cycle to automatically select the right wash and dry

See Details

View Demo



Team Whirlpool Project Overview

Windows 8 Apps for Smart Appliances

- Functionalities
 - Enable Whirlpool Customers to Manage Smart Appliances
 - Via *My Smart Appliance App*
 - For Windows 8 and Windows 8 Mobile
- Features
 - Support Windows 8 Family of Devices
 - Phones
 - Tablets
 - Laptops
 - Interface with Existing Whirlpool Cloud
 - Utilize Universal Windows Application Framework
 - Support Existing Features of iOS and Android Apps
- Technologies
 - Windows 8.1
 - Windows Phone 8.1
 - Visual Studio 2013
 - Whirlpool Smart Appliances
 - RESTful Web Service Layer

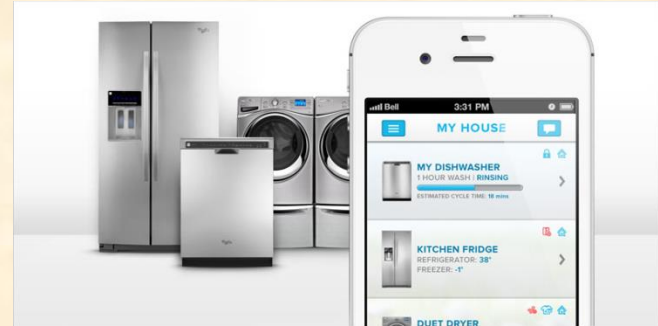

Benton Harbor, Michigan

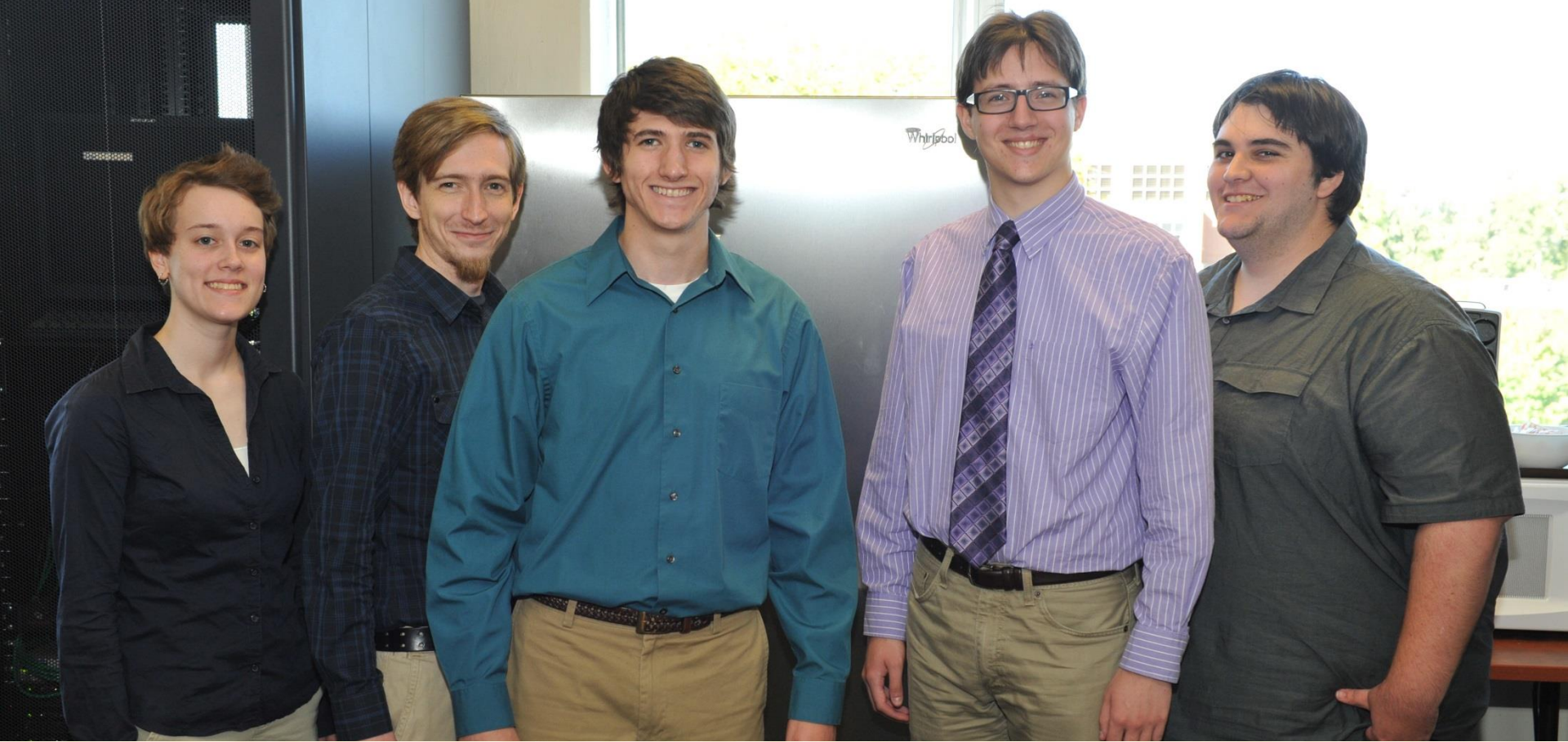

Team Whirlpool

Kathy Cummings, Chris Thomas, A. J. Sundheimer, Zachary Pauley, Robert Carpenter

Team Whirlpool Project Plan Presentation

Screen Mockups

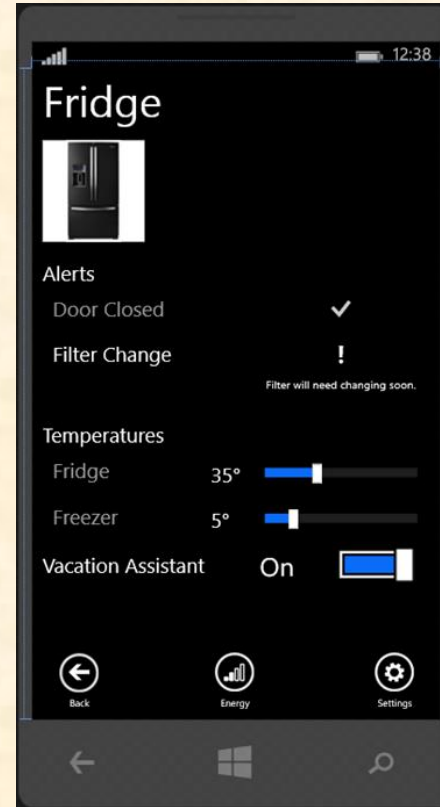
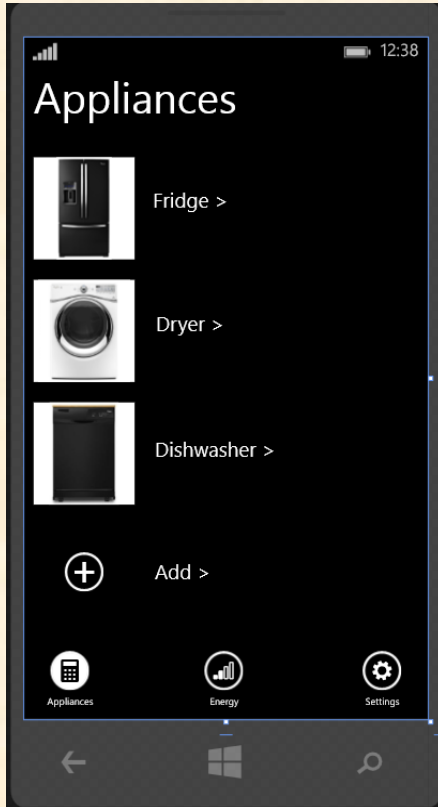



Team Whirlpool Project Plan Presentation

Team Whirlpool Project Plan Presentation

Architecture Diagram

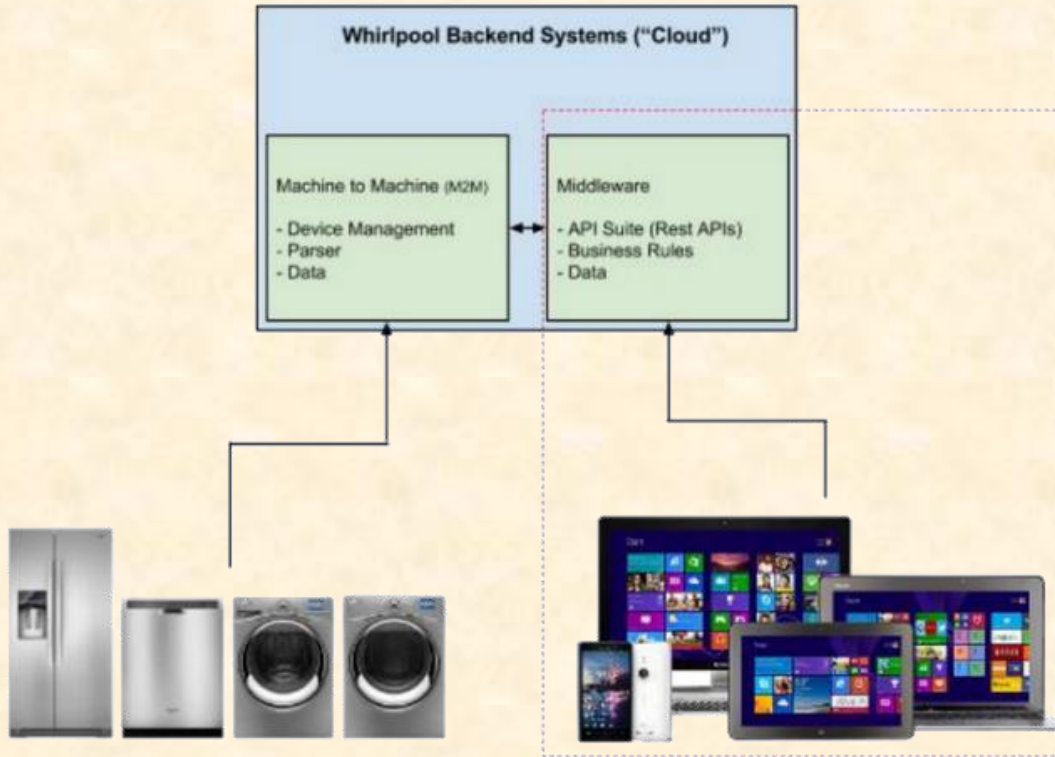



Team Whirlpool
Project Plan Presentation

Team Whirlpool Project Plan Presentation

Screen Mockups

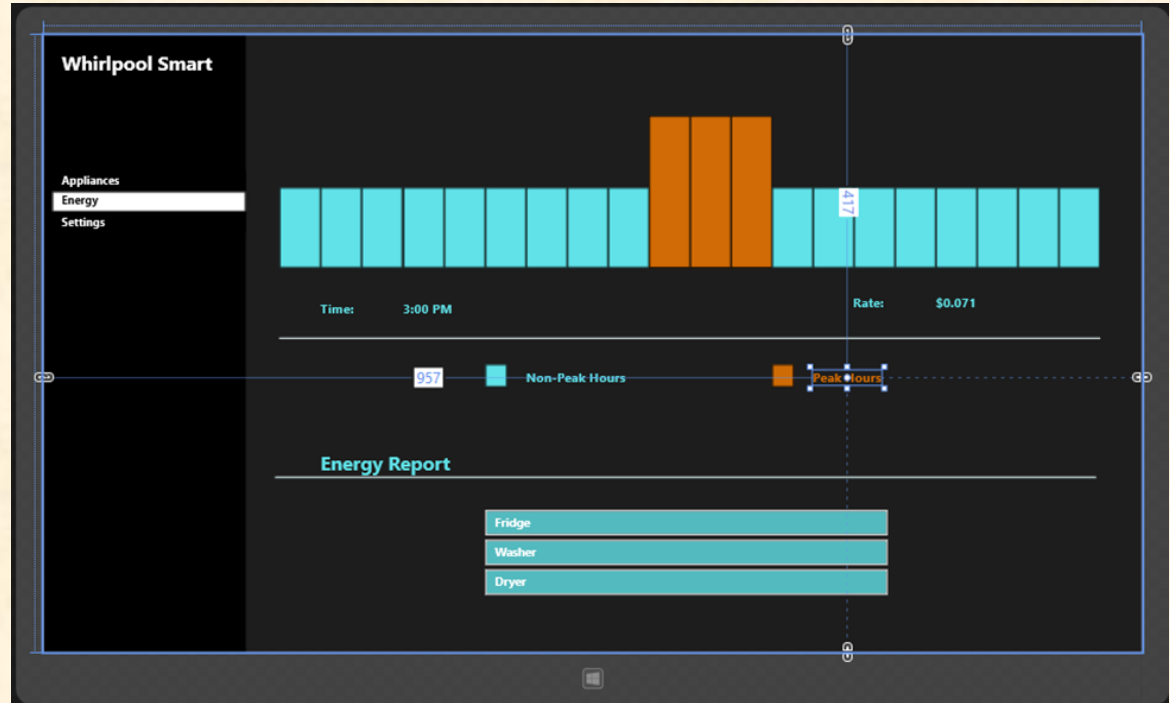
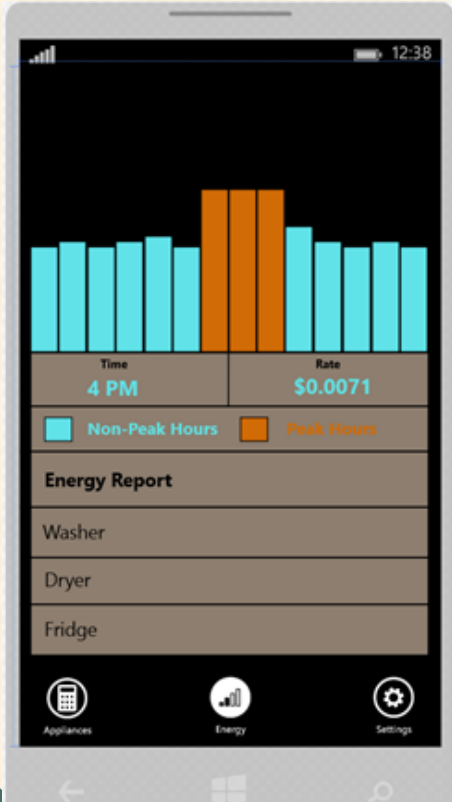



Team Whirlpool
Alpha Presentation

Team Whirlpool Alpha Presentation

Mobile Live Tiles

23:47

Smart

Photos

| Thu | Fri | Sat | Sun | Mon |
|-----|-----|-----|-----|-----|
| | | | | |
| 59° | 55° | 53° | 59° | 64° |
| 37° | 34° | 33° | 46° | 51° |

East Lansing

19:22

Smart

Photos

| Thu | Fri | Sat | Sun | Mon |
|-----|-----|-----|-----|-----|
| | | | | |
| 59° | 55° | 53° | 59° | 64° |
| 37° | 34° | 33° | 46° | 51° |

East Lansing

19:22

Refrigerator
Fridge: 37 degrees
Freezer: 2 degrees

Smart

Photos

East Lansing
Clear

57°F

59° 37°

WNW 6 mph

0 %

Weather



Team Whirlpool Alpha Presentation

Desktop Live Tiles

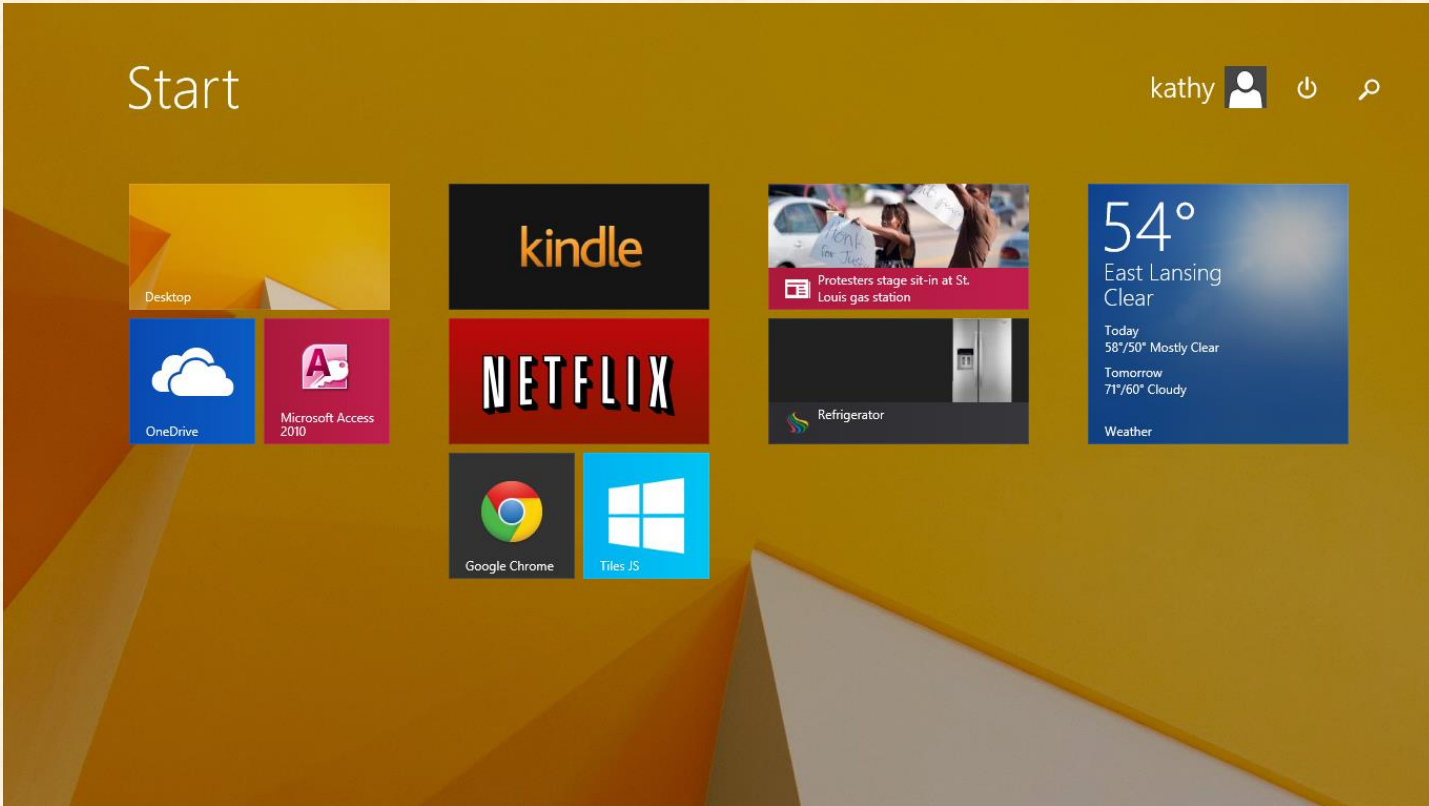



Team Whirlpool Alpha Presentation

Team Whirlpool Alpha Presentation Refrigerator, Energy and Options

← Refrigerator



Alerts

Door Closed ✓

Filter Change !
Filter will need changing soon.

Temperatures

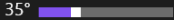
Fridge 35° 

Freezer 2° 

Vacation Assistant Off

Energy Report

Average Usage **863 Wh**

Total Usage This Week **5180 Wh**

Energy History

| Date | Usage (Wh) |
|------------|------------|
| 10/12/2014 | 840 Wh |
| 10/11/2014 | 860 Wh |
| 10/10/2014 | 810 Wh |

Options

Appliance Name

Notification Preferences

Push Email SMS

Door Ajar

Filter Bad

Error Messages

Smart Appliance ID
333336NMB5

Appliance Serial Number
R31004960





Team Whirlpool Beta Presentation

Team Whirlpool Beta Presentation

Account Appliances and Settings

Settings

Account About

Name

Team

Whirlpool

Account Email

teamwhirlpool498@gmail.com

Change Password

New Password

Confirm New Password

Energy Advisor On

Your Utility Company

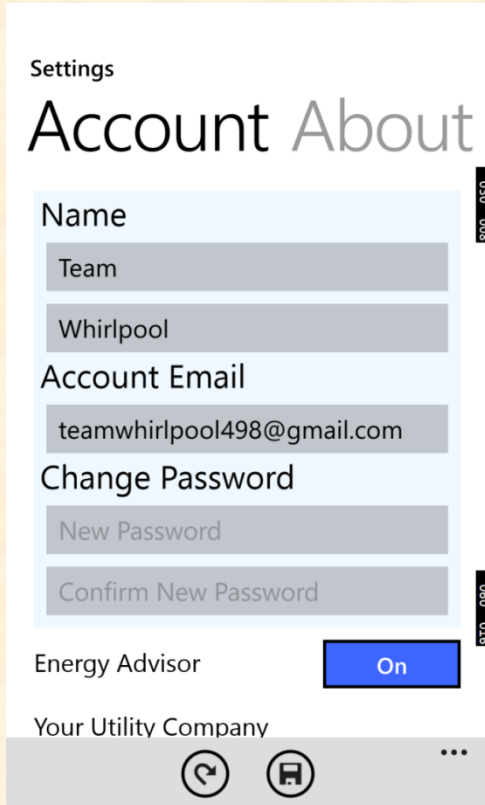
A mobile app interface for account settings. It features a title 'Settings' and a main heading 'Account About'. Below this are several input fields: 'Name' with 'Team' and 'Whirlpool' entered, 'Account Email' with 'teamwhirlpool498@gmail.com', and 'Change Password' with 'New Password' and 'Confirm New Password' fields. At the bottom, there is a toggle for 'Energy Advisor' which is turned 'On', and a section for 'Your Utility Company' with a menu icon. The interface is clean with a white background and grey accents.

Smart

Appliances Energy

 Clothes Dryer
Dryer
Idle
Wrinkle Shield: False

 Dishwasher
Dishwasher
Idle
Control Lock: False

 Refrigerator
Refrigerator
Refrigerator temp: 37°
Freezer temp: 0°

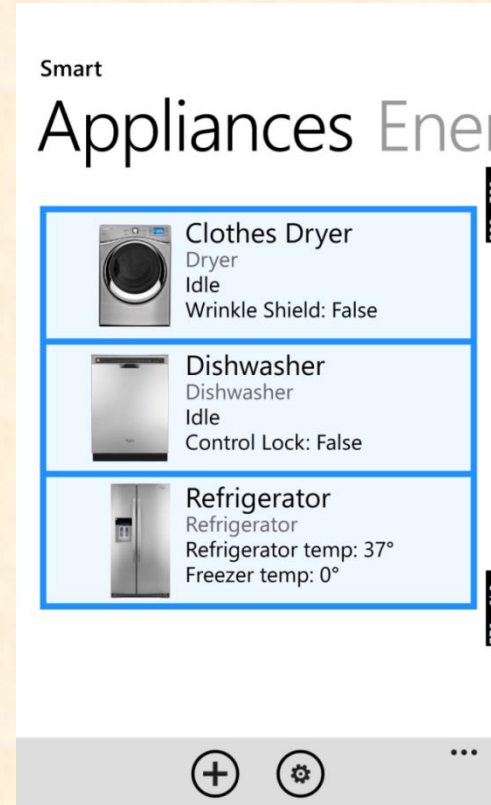
A mobile app interface for smart appliances. It features a title 'Smart' and a main heading 'Appliances Energy'. Below this are three appliance cards, each with a small image and text: 'Clothes Dryer' (Idle, Wrinkle Shield: False), 'Dishwasher' (Idle, Control Lock: False), and 'Refrigerator' (Refrigerator temp: 37°, Freezer temp: 0°). The interface is clean with a white background and grey accents.

Team Whirlpool Beta Presentation

Account Appliances and Settings

Smart Appliances



Clothes Dryer
Idle Wrinkle Shield: False



Capstone Fridge
Fridge: 38° Freezer: 0°



Dishwasher
Idle Control Lock: False

Energy

Rate Revealer

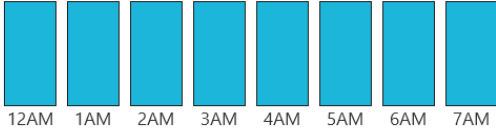

| Time | Rate |
|------|------|
| 12AM | High |
| 1AM | High |
| 2AM | High |
| 3AM | High |
| 4AM | High |
| 5AM | High |
| 6AM | High |
| 7AM | High |

Time

Account

← Account 

Team

Whirlpool

teamwhirlpool498@gmail.com

New Password

Confirm New Password

Energy Advisor On

Your Utility Company

Consumers Energy Co

Save

Delete Account





Team Whirlpool Beta Presentation

Team Whirlpool Beta Presentation

Refrigerator Specific Page

Refrigerator

Refrigerator Energy



Vacation Assistant
Off

Alerts

- Door Not Ajar ✓
- Filter Status ✓

Temperatures

| | | | |
|---------|---|-----|---|
| Fridge | ← | 37° | → |
| Freezer | ← | 0° | → |

Fahrenheit







Refrigerator

Energy Report

Average Daily Usage **1022 Wh**

-54161 Wh

Energy History

| | | |
|------------|--|---------|
| 11/3/2014 |  | 1293 Wh |
| 11/2/2014 |  | 1391 Wh |
| 11/1/2014 |  | 1388 Wh |
| 10/31/2014 |  | 1439 Wh |



Refrigerator

Options Refrigerator

Refrigerator

Notification Preferences

| | Push | Email | SMS |
|------------|--------------------------|-------------------------------------|-------------------------------------|
| Door Ajar | <input type="checkbox"/> | <input checked="" type="checkbox"/> | <input checked="" type="checkbox"/> |
| Filter Bad | <input type="checkbox"/> | <input checked="" type="checkbox"/> | <input type="checkbox"/> |
| Power Off | <input type="checkbox"/> | <input checked="" type="checkbox"/> | <input type="checkbox"/> |
| Power On | <input type="checkbox"/> | <input checked="" type="checkbox"/> | <input checked="" type="checkbox"/> |

Smart Appliance ID
333336NMB5

Appliance Serial Number
R31004960





Team Whirlpool
Design Day

MICHIGAN STATE

U N I V E R S I T Y

The Capstone Experience

Dr. Wayne Dyksen

Department of Computer Science and Engineering
Michigan State University
Fall 2014



*From Students...
...to Professionals*



Capstone Lab
View of Spartan Stadium



Capstone Lab
View of Spartan Stadium sans Smokestack



Capstone Lab
Winter View of Spartan Stadium

MICHIGAN STATE

U N I V E R S I T Y

The Capstone Experience

Design Day Award Winners

December 5, 2014



*From Students...
...to Professionals*



All-Hands
Design Day, December 5, 2014

MICHIGAN STATE
UNIVERSITY

COLLEGE OF ENGINEERING

innovation

excellence

leadership

vision

globalization

teamwork

COLLEGE OF
ENGINEERING

ENGINEERING

MICHIGAN STATE
UNIVERSITY

Auto-Owners Exhibition Award

Team Spectrum Health, Fall 2014

Employee Discount Mobile App

Ruchira Ramani, Josh Pelcher, Emily Van Norman, Marco Botros, Aries Xue

Scott Lake of Auto-Owners Insurance



MICHIGAN STATE
UNIVERSITY

COLLEGE OF ENGINEERING

ENGINEERING

innovation
excellence
leadership
vision
globalization
teamwork

COLLEGE OF
ENGINEERING

MICHIGAN STATE
UNIVERSITY

General Motors Praxis Award

Team Auto-Owners, Fall 2014

Navigation Assistant and Accident History App

Austin Huynh, Isaac Vogler, Zach Ray, Megan Frankel, Tim Sloncz

Presented by Christian Stier and Mike Adelson of General Motors

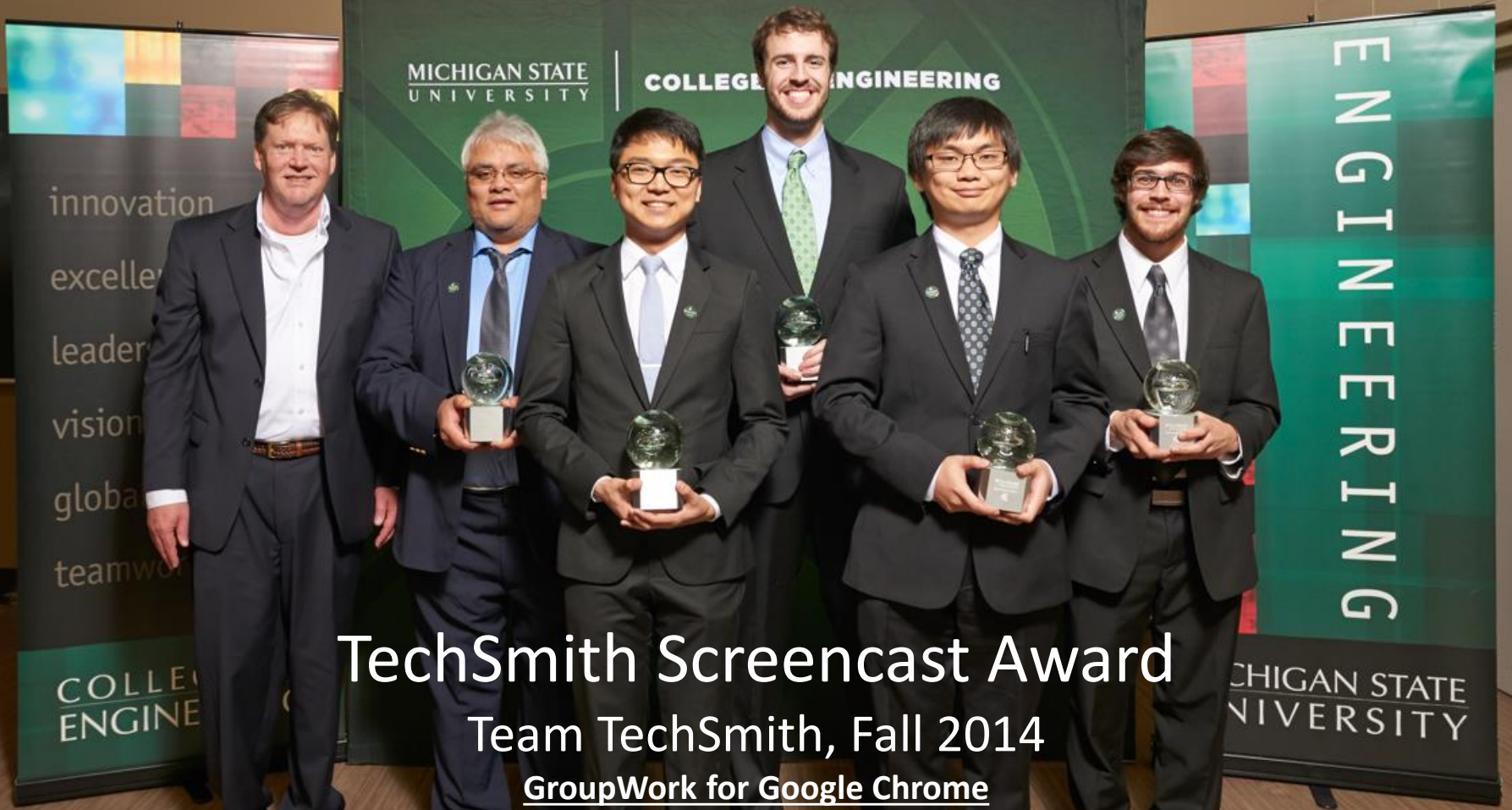

TechSmith Screencast Award

Team TechSmith, Fall 2014

GroupWork for Google Chrome

Gerald Kizer, Spencer Yi, Christian Fincher, Ryan Chen, Justin Fila

Presented by Dean Craven of TechSmith

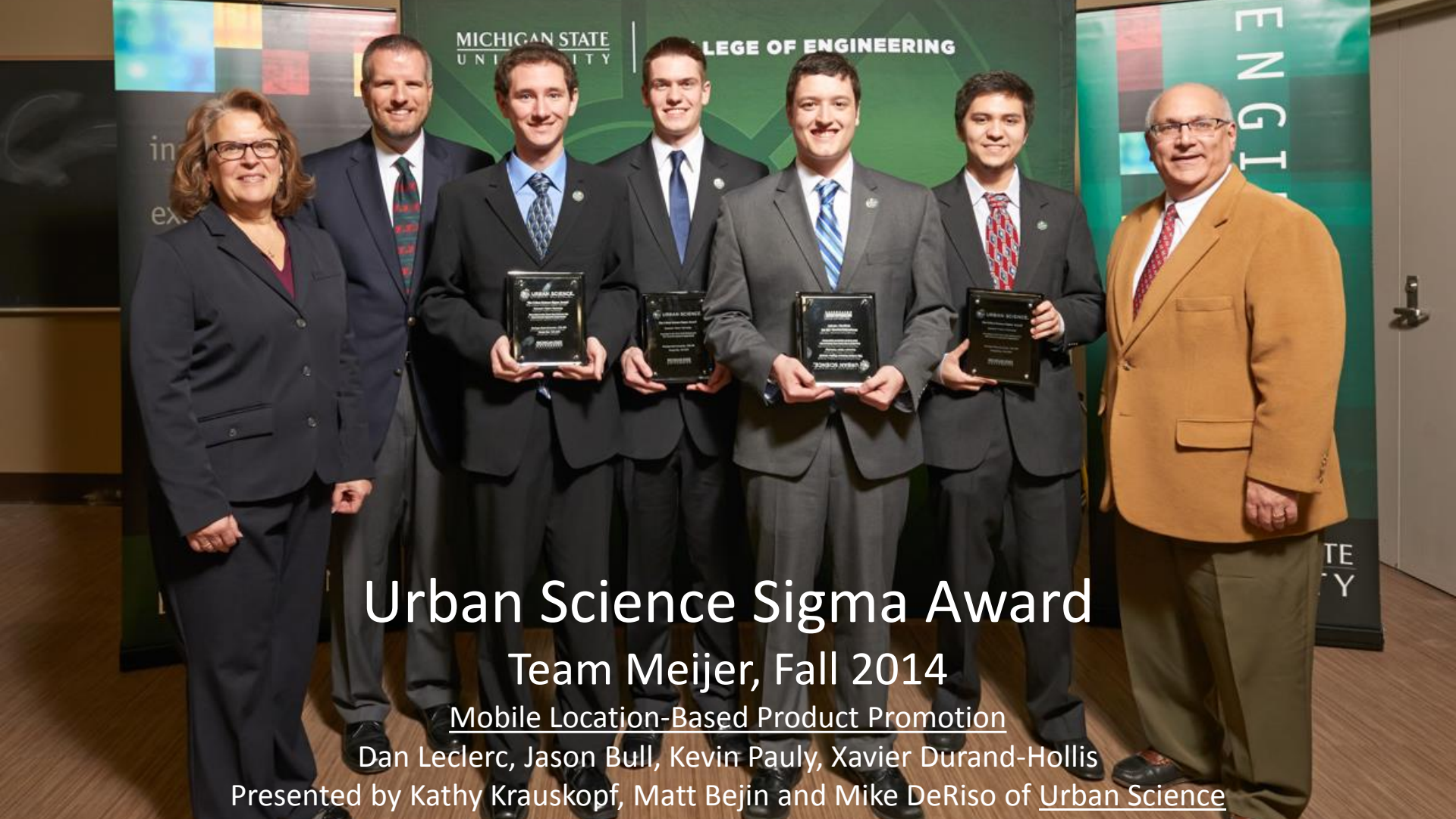

Urban Science Sigma Award

Team Meijer, Fall 2014

Mobile Location-Based Product Promotion

Dan Leclerc, Jason Bull, Kevin Pauly, Xavier Durand-Hollis

Presented by Kathy Krauskopf, Matt Bejin and Mike DeRiso of Urban Science

MICHIGAN STATE
UNIVERSITY

The Capstone Experience

Dr. Wayne Dyksen

Department of Computer Science and Engineering
Michigan State University
Fall 2014



*From Students...
...to Professionals*

amazon





Auto-Owners Insurance

Life Home Car Business

The "No Problem" People[®]



BOSCH

Invented for life





meijer[®]



F E D E R A L C R E D I T U N I O N

Building Dreams *Together*

Quicken[®] Loans[®]
Engineered to **AmazeSM**

SPECTRUM HEALTH





TechSmith®

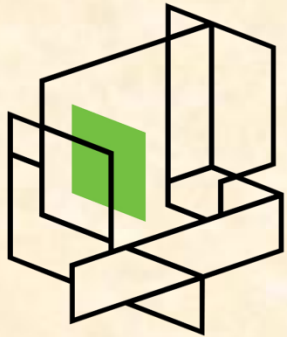

URBAN SCIENCE™



Whirlpool

CORPORATION

