

The MSU College of Engineering

Fall 2009

Design Day

Proudly sponsored by
Auto-Owners Insurance

MICHIGAN STATE
UNIVERSITY



AUTO-OWNERS INSURANCE COMPANY
AUTO-OWNERS LIFE INSURANCE COMPANY
HOME-OWNERS INSURANCE COMPANY
OWNERS INSURANCE COMPANY
PROPERTY-OWNERS INSURANCE COMPANY
SOUTHERN-OWNERS INSURANCE COMPANY



~ Serving Our Policyholders and Agents for More Than 90 Years ~

November 9, 2009

Dear Students, Family Members, Company Representatives, Alumni, Faculty & Staff:

On behalf of Auto-Owners Insurance Company, and in partnership with Michigan State University, it gives me great pleasure to welcome you to the beautiful MSU campus and specifically to the MSU College of Engineering Design Day. We are pleased and honored to partner with Michigan State University in this program, which showcases the talents and abilities of many gifted students.

We are particularly pleased to partner with MSU on this event. It has been said the future belongs to the youth. If this is the case (which we believe to be true) by the creativity, imagination, and initiative displayed by the participating students in this year's Design Day Program, you have to admit the future looks very bright indeed. A tremendous array of skills and abilities will be on display this year, which further substantiates our continued support of this program. We congratulate each participant along with those who have provided support, guidance and instruction to them.

As a recruiter of talent for the ongoing needs of our Company, I could not be more pleased with programs like Design Day, or the constant exposure to creative thinking that is provided through the daily course work at Michigan State University. We hire many graduates from numerous disciplines at MSU and as an alum, I could not be more proud.

I wish you a truly pleasant, exciting and stimulating day here on the MSU campus. May you be thrilled by the talent of the participants as well as the deep heritage of this Campus. We at Auto-Owners join in congratulating all the participants, proud parents and sponsors who took the initiative to support this program. Our best wishes to all for a wonderful day!

Sincerely,

Ronald H. Simon
Chairman and CEO



"Highest in Customer Satisfaction with the Auto Insurance Claims Experience"

-- J.D. Power and Associates



Program Page/Course Number

<i>A Note from the Design Day Coordinator Maureen E. Blazer-Adams</i>	2
<i>Design Day Events Schedule, Friday 11 December, 2009</i>	3
<i>Union Building Floor Plan</i>	4
<i>Staff Acknowledgements: College of Engineering Design Day</i>	5
<i>EGR 100: Introduction to Engineering Design: Need-based Concept Engineering</i>	6
<i>ME 371: Mechanical Design I: Thrills for Pre-Collegiates: Mechanisms that Fascinate, Captivate, Stimulate and Entice</i>	7
<i>ME 412: Heat Transfer Laboratory: The Mean Green Ice Melting Machine</i>	8
<i>ME 456: Mechatronic Systems Design: Prototypes of Commercial Products</i>	9
<i>ME 471: Mechanical Design II: Horizontal Extension Arm</i>	10
<i>CSE 498 Computer Science & Engineering Projects: Presentation Schedule–Lake Erie Room</i>	11
<i>Auto-Owners Insurance Company: Applications for Mobile Devices</i>	12
<i>The Boeing Company: Sparse Virtual Texturing</i>	13
<i>GE Aviation: Synthetic Vision Display</i>	14
<i>Meijer: It's Scorecard Dashboard</i>	15
<i>Motorola: Mobile User Generated Video Service</i>	16
<i>TechSmith Corporation: Microsoft Team System Custom Client</i>	17
<i>The Toro Company: Irrigation Distribution Uniformity Analysis</i>	18
<i>Urban Science: Automobile Dealership Dashboard</i>	19
<i>ECE 480/ME 481 Engineering Design Projects: Presentation Schedule–Lake Huron Room</i>	21
<i>MSU RCPD: Body Temperature Regulator Vest for Quadriplegic Patient</i>	22
<i>AMSaC Research Group: Low-cost Electrochemical Sensor</i>	23
<i>Texas Instruments: Power-Over-Ethernet for Wireless Home Automation</i>	24
<i>Norfolk Southern: Cracked Rail Spike Detector</i>	25
<i>Whirlpool: Lowering Standby Power Consumption Via Proximity Detection</i>	26
<i>United States Air Force Research Laboratory: Small, Lightweight Speed and Distance Sensor for Skiers and Snowboarders</i>	27
<i>Mid-Michigan Medical Center: Steering Design of the Push-Pull Recumbent Cycle</i>	28
<i>Sparrow Pediatric Rehabilitation Center: Pediatric Exercise Equipment</i>	29
<i>Sparrow Pediatric Rehabilitation Center: Hands-Free Gait Trainer</i>	30
<i>Ford Motor Company: Refueling Effects of Fluid Flow Behavior in Fuel Pump Nozzles</i>	31
<i>CE 495 Design Projects: Senior Design in Civil Engineering MSU and Lake Michigan Rooms</i>	32-33
<i>ChE 434: Senior Design Course in Chemical Engineering &</i>	
<i>MSE 466: Senior Capstone in Materials Science & Engineering</i>	36
<i>ME 481 Mechanical Engineering Design Projects: Presentation Schedule–Lake Superior Room</i>	37
<i>NatGasCar LLC: Natural Gas Drying System for CNG Vehicle Refueling Appliance</i>	38
<i>A Shell Oil Company Children's Humanitarian Project: Bus Step Simulator for Heartwood School</i>	39
<i>Airmaster Fan Company: Development of a New Fan for the Retail Market</i>	40
<i>General Motors Company: Upper Reveal Molding and Appliqué System for Applied Door Window Frame Construction</i>	41
<i>General Motors Company: Re-Design of the Cadillac SRX Tail Lamp Locating Strategy for Variation</i>	42
<i>Louis Padnos Iron & Metal/John Ball Zoo: Geothermal Replacement of a Conventional Chiller</i>	43
<i>Green Vortex: Two-Flush Toilet System</i>	44
<i>Motorola: Mobile Device with a Flexible Display</i>	45
<i>The Motorola Foundation Youth in Energy and Environment Humanitarian Project: Biomass Energy Demonstrator for Woodcreek Elementary School</i>	46
<i>Lefevre Corporation: Redesign of Granulator Blades</i>	47
<i>BE 485/487: Biosystems Engineering</i>	48-49
<i>Design Day Awards: Electrical and Computer Engineering, Mechanical Engineering, Computer Science Engineering, Civil and Environmental Engineering and Applied Engineering Sciences</i>	52-57
<i>The Dart Foundation Day: December 11th 2009: Middle School & High School Events Schedule</i>	58-59



A note from the Design Day Coordinator

The College of Engineering welcomes you to Design Day! We wish you a very memorable event as you experience our students and their amazing talents through presentations, competitions, and posters.

The support of an Executive Partner is a key addition to Design Day. We are proud to recognize Auto-Owners Insurance as the inaugural Executive Partner. As a Lansing based Fortune 500 company, Auto-Owners Insurance has a rich history of engagement with Michigan State University.

As you visit our various exhibits throughout the MSU Union, please make sure you learn about the projects. Our students are an incredible group of people who love to share their enthusiasm for engineering.

An exciting part of Design Day is the approximately 200 middle school and high school students participating in the Dart Foundation Day of Engineering Innovation and Creativity for 7th-12th Grade Students. These future engineers will explore design principles with hands-on projects requiring the application of their creativity and ingenuity.

The headliners of the day are our graduating seniors as they present their design projects through exhibits, posters, and presentations. These projects represent the capstone of their educational career. You will see that MSU engineers are ready to lead, create, and innovate.

Design Day would not be possible without the continued support of our project sponsors who provide both funding and a professional experience for our capstone design teams.

Along with our Executive Partner, Auto-Owners Insurance, we thank our Supporting Partners, Dow Chemical Corporation and Medtronics.

Please join us for the Design Day Awards ceremony in the Ballroom at 1:15 pm when we will honor all of our talented Spartans, the best of the best.







Sincerely,

A handwritten signature in black ink that reads "Maureen E. Blazer-Adams". The signature is written in a cursive, flowing style.

Maureen E. Blazer-Adams
Design Day Coordinator
MSU College of Engineering

Design Day Events Schedule: Friday, December 11, 2009

EVENTS	8 a.m.	9 a.m.	10 a.m.	11 a.m.	Noon	1 p.m.
Audio Enthusiasts and Engineers	2nd Floor Concourse 8:00 a.m. – 1:00 p.m.					
Engineering Student Organizations		2nd Floor Concourse 9:00 a.m. – noon				
EGR 100 Presentations		2nd Floor Ballroom 9:00 a.m. – noon				
ME 371 Demonstrations		Gold A&B 9:00 a.m. - noon				
ME 412 Competition	Parlor A 8:00 a.m. - noon					
ME 456 Presentations	Lake Ontario Room 8:00 a.m. - noon					
ME 471 Competition		Ballroom 9:00 a.m. - noon				
CAPSTONE COURSES						
Capstone Posters	1st Floor Lounge 8:00 a.m. - noon					
ECE 480 Presentations	Lake Huron Room 8:00 a.m. – 10:50 a.m.					
ME 481 Presentations				Lake Huron 10:50 a.m. - 12:30p.m.		
ME 481 Project Presentations	Lake Superior Room 8:00 a.m. - 12:30 p.m.					
CE 495 Project Presentations	Lake Michigan Room 8:00 - 11:40 a.m.					
CE 495 Project Presentations	MSU Room 8:00 - 11:40 a.m.					
CSE 498 Project Presentations	Lake Erie Room 8:00 a.m. - 11:40 a.m.					
LUNCH AND AWARDS						
Woodcreek Lunch			Green Room 12:00 p.m. - 12:30 p.m.			
MSU Lunch			2nd Floor Concourse 12:15 p.m. - 1:00 p.m.			
MSU Awards				Ballroom 1:15 p.m.- 2:00p.m.		
School Lunch			Parlor C Noon - 12:30 p.m.			
School Awards			Ballroom 12:30p.m. - 1 p.m.			

KEY:  EGR event  MSE event  School event
 CE event  CSE event  ME event

Conference Events Schedule: Floor Maps

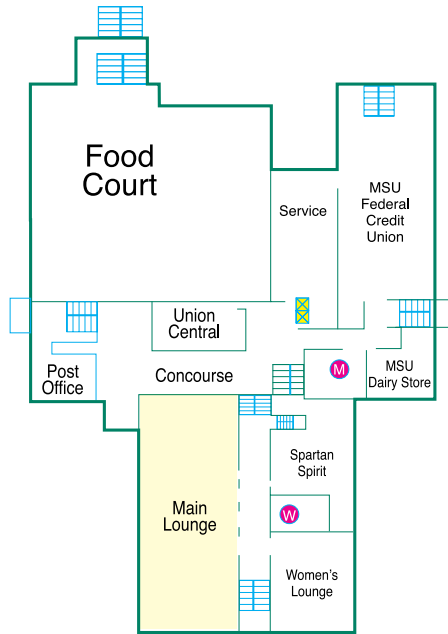

First Floor

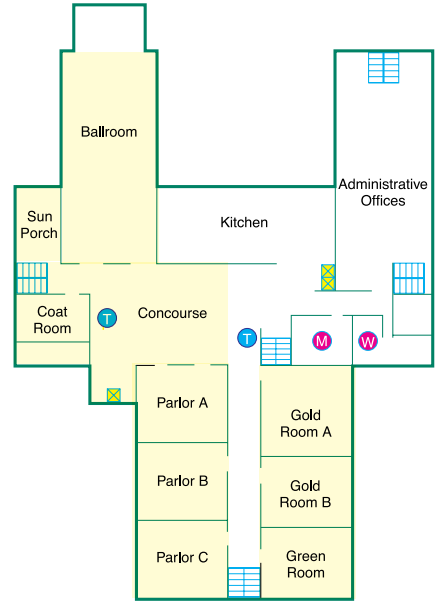

Second Floor

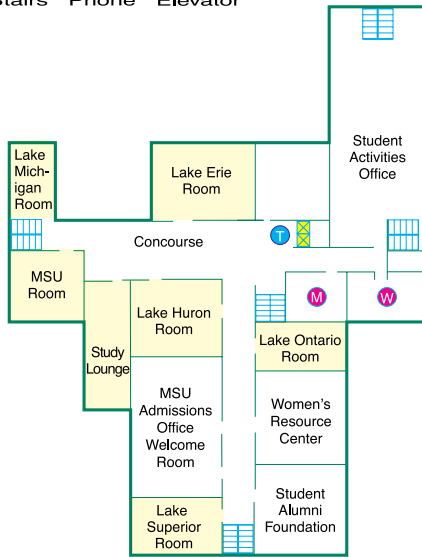
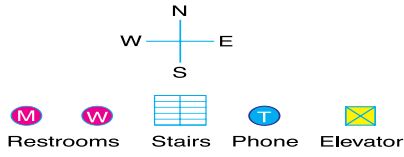

Third Floor

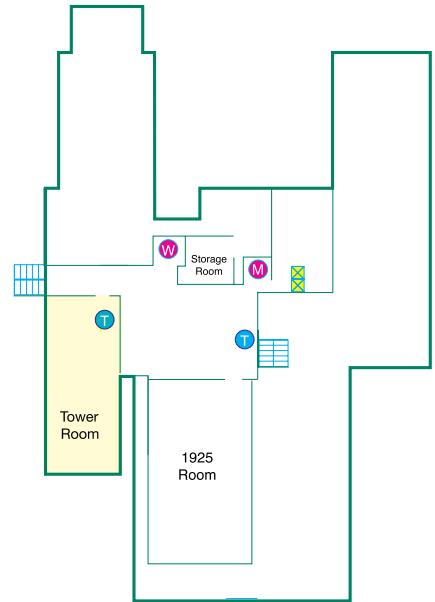

Fourth Floor

MSU Union Floor Plan

College of Engineering Design Day: 11th December 2009

STAFF ACKNOWLEDGEMENTS:



Roy Bailiff



Jill Bielawski



Linda Clifford



Kelly Climer



Cathy Davison



Craig Gunn



Phil Hill



Matt Jennings



Debbie Kruch



Matt Luciw



Jamie Lynn Marks



Garth
Motschenbacher



Mary Mroz



Gregg Mulder



Roxanne Peacock



Adam Pitcher



Norma Teague



Teresa VanderSloot



Brian Wright

MACHINE SHOP AND DESIGN LAB STAFF:

Ken Barlage
Russ Tindall
Colin Perrault

EGR 100

9:00 – Noon
Second Floor
Ballroom

EGR 100 Introduction to Engineering Design

NEED-BASED CONCEPT ENGINEERING

INSTRUCTIONAL TEAM: Dr. Neeraj Buch, Dr. David Grummon, Mr. Timothy Hinds, Dr. Bradley Marks, Dr. Jon Sticklen, Dr. George Stockman, Dr. Xiaobo Tan, Dr. S. Patrick Walton, Dr. Thomas Wolff

TA STAFF: Wouter Brink, Carl Coppola, Aaron Greiner, Becky Larson, Adam Rogensues, Brian Romanowski, Emily Wandell

MENTOR STAFF: Amy Bittinger, Jacob Co, Austin Crawley, Michael Douglass, Eric Ford, Kyle Korson, Sri Kumar, Nicholas Lehman, Eric McElmurry, Allison Mills, Michael Opperman, Justin Raymond, Ishaan Sandhu, Nick Sears, Steven Soave, Russell Tindall, Patrick Triscari, Jessica Warda, Brad Wardynski, Ollie Zemanek

PROBLEM STATEMENT

EGR 100, Introduction to Engineering Design, is a new, college-level course being taken by all incoming first-year engineering students. It is an integral part of the Cornerstone Engineering/Spartan Engineering program. The course introduces students to the engineering profession and the engineering design process through team-based, interdisciplinary design projects and assignments. Over 500 students are enrolled in EGR 100 this semester.

The final course project had teams of EGR 100 students design a new product or process to remove a frequent inconvenience in their daily lives. Their design concepts were to be something new or a significant improvement to an existing product or process. The teams were to approach the project using the perspective of the engineering discipline they plan to pursue through their academic careers. The teams built prototypes of their concepts not exceeding a total material cost of \$20. The teams will display their prototypes at Design Day along with a poster detailing their concept designs. Pre-college students will recognize the most outstanding projects with awards.



Dr. Buch



Dr. Grummon



Mr. Hinds



Dr. Marks



Dr. Sticklen



Dr. Stockman

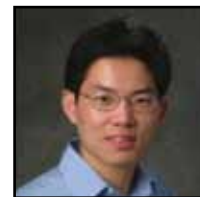

Dr. Tan



Dr. Walton



Dr. Wolff



THRILLS FOR PRE-COLLEGIATES: MECHANISMS THAT FASCINATE, CAPTIVATE, STIMULATE AND ENTICE

INSTRUCTOR: Professor Brian Thompson

PROBLEM STATEMENT

Teams of students were required to design and manufacture mechanisms that would thrill an audience of pre-collegiate students. The only constraints imposed upon the assignment were that each mechanism must incorporate at least one linkage, one gear set and one cam-follower combination. These engineering marvels will be displayed along with a complementary poster explaining the subtleties of each mechanism and each device will be demonstrated to the eager audience. Every ME371 team will be interviewed by the pre-collegiate students who will evaluate the display and assign points to provide a measure of its merit. Subsequently these points will be tallied and the winning team awarded the *Sparty Plaque* for creating the most thrilling mechanism. This inspiring plaque was designed and fabricated by students at Holt Junior High School.

Teams and members

Team 1

Edward Belanger
Harold Hill
Namic Kerimov
Manila Ounsombath

Team 2

John Peterson
Kyle Spiekermann
Alexander Suraja
Erik Sunderberg

Team 3

Alexander Douglas
Alan Finder
John Schultz
Matthew Snell

Team 4

Jeffrey Holley
Andrew Kappler
Brian Smith
Joeseoph Wesorick

Team 5

Hassan Alzayer
Peter Anthony
John Schiefer
Robert Wooten

Team 6

Thomas Dennis
Joshua Dewalt
Matthew Flis
Andrew Gallihugh

Team 7

Tao Han
Jarreau Jackson
Kristin Steinmetz
Justin Ward

Team 8

Darren Fung
Courtney MacDonald
Curt Mumaw
Daniel Tepe

Team 9

Andrew Chiesa
Logan Larson
Evan Racine
Perrin Vanderveen

Team 10

Adam Blumerich
Garrett Kerns
Ross Loynes
Joe Rotellini

Team 11

Brandon Gray
Saad Khan
Jeongseop Lee
Charles McGovern

Team 12

Trevor Betz
Nicholas Dallapiazza
Eric Massa
Peter Strom

Team 13

Nicholas Huehl
Nick Kuuttilla
Amar Shah
Steven Soave

Team 14

Brendan Ayer
Kenneth Eschbach
Andrew Vanderklok
Corrie Zitkus

Team 15

Luis Alvarez
Jack Johnson
Benjamin Nutsch
Peter Redente

Team 16

Kelly Burke
David Kempf
Manpreet Singh
Alexander Tollis

Team 17

Rachel Jaquin
Jelena Paripovic
Christopher Rawsky
Caroline Skuta

Team 18

Michelle Flachs
Katelin Friederichs
Alexander Hsieh
Nichole Kramer

Team 19

Benjamin Cherwinski
Alexander Gage
Jeremy Racine

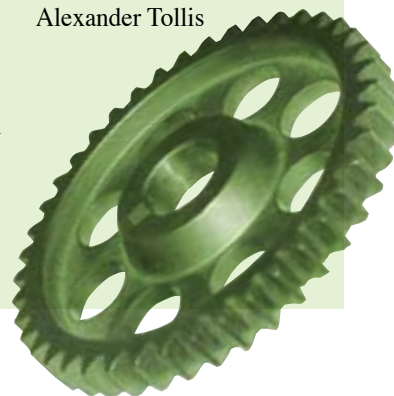

ME 412

8:00 – Noon
Second Floor
Parlor A



THE MEAN GREEN ICE MELTING MACHINE

INSTRUCTOR: Dr. Laura J. Genik

TA Staff: Paul Strefling, Jeffery Stricker

You have seen them on television, the Miracle Thaw[®] or Super D frost Wonder[®] where hamburger patties are defrosted in less than ten minutes and an ice cube melts as though on a hot griddle, but these devices are cool to the touch. Is this some sham, or could it be real heat transfer at work? Only a Heat Transfer Lab student will know for sure.

PROBLEM STATEMENT

The project team is to design, analyze, build and test a heat transfer device to enhance the defrost process as realized by the energy transfer to melting ice. The device may have an active energy input, e.g. batteries or wall electricity, but the amount of active energy provided will be subtracted from the melting ice energy. To remain in context with the above described device, the ice may not be modified in any manner. The device must also begin at room temperature. The project team is to consist of no more than three students. The device will be judged on the basis of the energy rate of ice melting, the mass of the device, and its cost. The device must fit inside a box of dimension 14" x 14" x 12".

TIME	DESIGN TEAM
8:50	Kunjan Patel, Kelly Peterson, Eva Reiter
9:00	Derek Baker, Amy Bittinger, Tyler Curtis
9:10	Harold Black , Christopher Ezop, Mathieu Rich
9:20	Stephanie Bonner, Stephen Hukill, Mackenzie Schmidt
9:30	Louis Cervone, Caitlin Hojnacki , Jeffrey Laforge
9:40	Brandon Hengesbach, Bryan Maxwell, Case Vandenkieboom
9:50	Nathaniel Davis, Ross Weaver, Marissa Wiltz
10:00	Paul Allen, Elizabeth Carroll, Andrew Rogers
10:10	Timothy Aspinall, Nicholas O'dell, Matthew Owens
10:20	Matthew Burdick, Kaitlin Donoughe, Benjamin Llewellyn
10:30	James Guitar, Michael Karoub, Eric Vine
10:40	Joel Darin, Brandon Kelly, Thomas Michalik, Ryan Wood
10:50	Ryan Lindeman, Michael McPhail, Hengye Zhang
11:00	Alexandre Oliveira, Fernando Oliveira, Andrew Tonkovich
11:20	Benjamin Lindstrom, Phillip Marino, Samuel Tkac



PROTOTYPES OF COMMERCIAL PRODUCTS

INSTRUCTOR: Professor Clark Radcliffe

TA Staff: Sara Murawa

PROBLEM STATEMENT

The students in this course were challenged to develop, test, and demonstrate an innovative design for a commercial product that synthesized mechanical, electrical and fluidic components plus imbedded microcontrollers. Typical applications range from automotive engine controls and robotic manufacturing systems to toys and consumer appliances such as microwave ovens. Each group will make a 15-minute presentation and demonstration of a working prototype of their product.

Mechatronics Systems Design

TEAM	TIME	MEMBERS
1	9:10	Michikazu Aono, Devesh Chaphalkar, David Lantzy, Matthew Owens
2	9:30	Phillip Marino, Joseph Marotta, Krishna Vistarakula
3	9:50	Charles Baird, Neil Ferguson, Joshua Samp, Daniel Schleh
4	10:10	Rickey Caldwell, Lucas Fratta, John Woodruff
5	10:30	Harold Black, Caitlin Hojnacki, Mackenzie Schmidt, James Yizze
6	10:50	Stephanie Bonner, Brittany Haberstroh, Stephen Hukill, Shangyun Shi
7	11:10	Michael Karoub, Eric McElmurry, Brian Warner
8	11:30	Matthew Burdick, Paul Strefling, John Stukel, Jessica Warda

ME 471

9:00 – Noon
Second Floor
Ballroom



ME 471: MECHANICAL DESIGN II HORIZONTAL EXTENSION ARM

INSTRUCTORS: Farhang Pourboghrat and Scott Kiefer
TA: Oishik Sen

PROBLEM STATEMENT

Students in ME 471 were challenged to design and build a prototype apparatus for a horizontal extension arm. The arm would be representative of a device that could be used in a manufacturing environment for material handling or assembly. Because of the limitations of testing on Design Day, testing will be done on a small scale model. Specifically, the students will be required to move an 11 lb. weight across a 36 inch distance. Students must perform a complete analysis before the contest to predict the deflection of their device and the load that will cause their device to fail.

Mechanical Design II

TIME	GROUP MEMBERS
9:00	Lucan Fratta, Mollie Montague, Diana Toan
9:10	Kyle Bateman, Brandon Kelly, Brian Warner
9:20	Mirsena Lekovic, Ricardo de Majo, Florian Pribadi, James Yizze
9:30	Michael Douglas, Mark Holmes, Nick Lehman, Nicholas Stuart
9:40	Maurer Abdurahmanovic, Daniel Goettlicher, David Parke, Ryan Rosenburg
9:50	Eric Ford, Michael McPhail, Jessica Warda, Oliver Zemanek
10:00	Alex Dupay, Chris Fairbanks, Jon Pishney, Hengye Zhang
10:10	Justin Meeder, TJ Qualman, Jake Sprague, Cody Wagner
10:20	Neil Jessel, Thomas Michalik, Hasib Mohammed, Alexandre Oliveira
10:30	Chris Lange, Jeff Movsesian, Matthew Pung, Matt Weir
10:40	Clarence Huff, James Peers, Keith Solomon, Eric Wickenheiser
10:50	Dev Chaphalkar, Ashley Kulczycki, Matt Waggy



COMPUTER SCIENCE AND ENGINEERING CAPSTONE COURSE PROJECTS

PRESENTATION SCHEDULE – Lake Erie Room

Prof. Wayne Dyksen

Erie

8:00 – 11:20
Third Floor
Lake Erie Room

Time	Company	Project Title
8:00	Auto-Owners Insurance Company	Applications for Mobile Devices
8:25	The Boeing Company	Sparse Virtual Texting
8:50	GE Aviation	Synthetic Vision Display
9:15	Meijer	ITS Scoreboard Dashboard
9:40	Motorola	Mobile User Generated Video Service
10:05	TechSmith Corporation	Microsoft Team System Custom Client
10:30	The Toro Company	Irrigation Distribution Uniformity Analysis
10:55	Urban Science	Automobile Dealership Dashboard

CSE 498 Collaborative Design

CSE 498, Collaborative Design, provides the educational capstone experience for all students majoring in computer science. The course objectives include the following:

- Learning to architect, develop, and deliver a comprehensive software system to a client;
- Learning to work effectively in a team environment;
- Developing written and oral communication skills;
- Becoming proficient with software development tools and environments;
- Learning about system building and system administration; and
- Considering issues of professionalism and ethics.

Corporate clients are local, regional, and national, including Accident Fund, Auto-Owners Insurance, Boeing, Chrysler, Ford, GE Aviation, GM, IBM, Meijer, Microsoft, Motorola, Sircon, TechSmith, Terex, Toro, Two Men and a Truck, the Union Pacific Railroad, and Urban Science.

AUTO-OWNERS INSURANCE COMPANY APPLICATIONS FOR MOBILE DEVICES

Auto-Owners Insurance was founded in 1916 and is among the premier insurance companies in the country. Understanding customer needs and providing great service are among the top priorities of the company.

With the increasing usage of mobile devices, it is becoming extremely critical for companies to provide mobile solutions for their customers.

Working with Auto-Owners Insurance, we developed a mobile application for the three major mobile platforms: iPhone, BlackBerry, and Windows Mobile. With our application, mobile users can locate nearby independent Auto-Owners agents on a map via GPS or searching by address or zip code.

Auto-Owners Insurance Independent Agents can also use our application to begin the formal insurance claim process to provide a speedy response their customers. Auto-Owners Insurance customers can gather information about a potential claim and send this information to their agent, or they can store it for later use.

As an example scenario, an Auto-Owners Insurance customer has a car accident. The customer would use our application to gather information about the accident, including pictures. The customer would then search for an Auto-Owners Insurance agent to contact them about their potential claim. The applications were developed using Objective-C for iPhone, Java for BlackBerry, and C# for Windows Mobile.

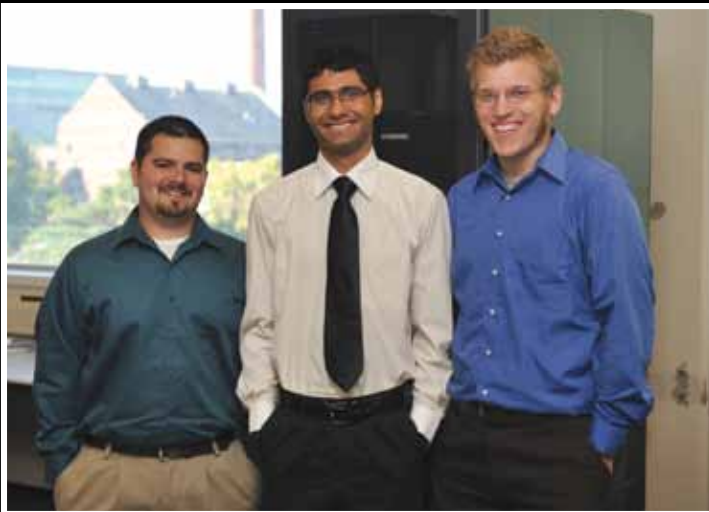

Michigan State University Team Members (left to right)

Ricardo Silva
St. Helen, Michigan

Lovelesh Chawla
Lansing, Michigan

Luke Hospadaruk
Ann Arbor, Michigan

Auto-Owners Insurance Corporate Sponsors

Bob Buchanan
Lansing, Michigan

Scott Lake
Lansing, Michigan

Peter Peltier
Lansing, Michigan

THE BOEING COMPANY

SPARSE VIRTUAL TEXTURING

With drastic advances in visual technology, there has been an increasing demand for high definition imagery in games and simulation software. This is a problem, as high definition images can require larger amounts of memory than are available. The Sparse Virtual Texturing project is a tool that allows for the use of such images in real-time. Current techniques for displaying textures (2D images placed upon 3D models) store the entire texture when only a small fraction of it may be visible on the screen. For example, when viewing the Western Hemisphere on a model of Earth, even though the Eastern Hemisphere cannot be seen it is still being loaded into memory.

The Sparse Virtual Texturing project only loads the parts of the texture that are actually being viewed. So when viewing the Western Hemisphere on a model of the Earth, this project does not store the portion of the texture containing the Eastern Hemisphere.

The extra memory that this technique frees up allows the use of higher definition textures than would normally be possible. The end result is higher quality visuals and more realistic simulation and game scenery, or the same quality visuals with better performance.

The Sparse Virtual Texturing project is implemented as an extension for OpenSceneGraph, and will be integrated into Boeing Modeling & Simulation Visual applications.

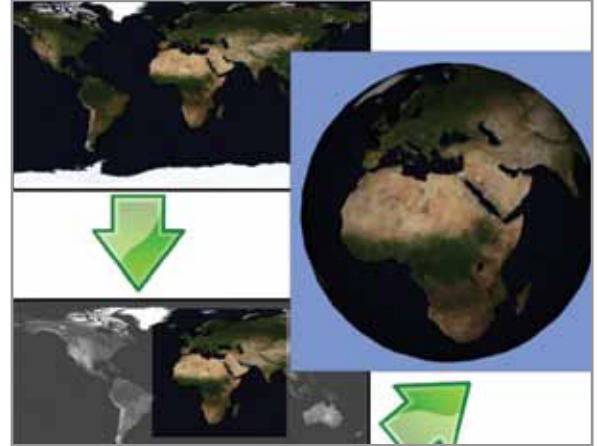

Michigan State University Team Members (left to right)

Adam Starks
Dallas, Texas

Patrick Ohren
Lansing, Michigan

James Drallos
Bloomfield Hills, Michigan

Alexander Kobylarek
Novi, Michigan

Boeing Corporate Sponsors

Pete Clive
St. Louis, Missouri

Matt Daniels
St. Louis, Missouri

Jonathon Marjamaa
St. Louis, Missouri

Lorne Mitchell
St. Louis, Missouri

Jayson Vincent
St. Louis, Missouri

Steve Yallaly
St. Louis, Missouri

GE AVIATION SYNTHETIC VISION DISPLAY

The GE Aviation Synthetic Vision Display makes the arduous task of piloting a plane much easier. And with the safety of the crew and passengers in mind, giving a pilot less to worry about could not be more important.

Using a flight simulator to stream flight data and reliable terrain information, a variety of unique flight instruments can be created. After being processed and sent via network to the client machine, a Synthetic Vision Display is rendered with several features designed to make a pilot's flight easier.

Accurately rendered terrain replaces the standard blue and brown rectangles, giving a pilot a better correlation between instrumentation and what would be visible from the main window. Further, the terrain rendered in the display simulates clear weather, allowing much greater visibility if actual weather conditions are poor.

Other features include coloration of rendered terrain to show relative elevation to the plane. In short, should the plane be in any danger of colliding with terrain, said terrain shall be rendered in red to ensure the pilot is aware of a need to avoid it. Terrain posing only a moderate risk will be rendered in yellow. Green terrain will not pose the pilot any risk.

Flight paths and airports are also shown on the Synthetic Vision Display, allowing the pilot greater situational awareness in even the worst conditions.

A pilot's job just got easier.



Michigan State University

Team Members (left to right)

Andrew Inman
Mount Clemens, Michigan

Justin Kienle
Clinton Township, Michigan

Jesse Hacker
Livonia, Michigan

Andrew Gerber
Hudsonville, Michigan

GE Aviation

Corporate Sponsors

Aaron Gannon
Phoenix, Arizona

Timothy Burns
Grand Rapids, Michigan

MEIJER ITS SCORECARD DASHBOARD

The Meijer ITS Scorecard Dashboard allows directors and managers within the Information Technology Services department a way to view summarized performance statistics regarding change and incident management.

A change consists of a modification to the current IT infrastructure. An incident refers to an issue that needs to be resolved. The Scorecard Dashboard summarizes key performance statistics regarding changes and incidents, and displays this information to end users through an intuitive graphical interface.

The Scorecard Dashboard utilizes stop-lighting, which allows users to view a manager's performance through a colored range scheme. Trending is accomplished through arrowed symbols that indicate a manager's performance over past periods. Charts allow for a visual comparison of statistics among managers that report to a specific director. Users can also drill down to a specific manager and view graphs that summarize performance and efficiency.

The Scorecard Dashboard is integrated with Microsoft Office SharePoint 2007. The capabilities and versatility of SharePoint ensures that the ITS Scorecard Dashboard will provide a useful tool for managers and directors.

The Scorecard Dashboard utilizes SharePoint 2007, ASP.NET and C#. Data is stored in SQL Server 2008.



Michigan State University
Team Members (left to right)

John Rekoumis
Northville, Michigan

Matthew Wincek
Rochester, Michigan

Kareem Janoudi
Okemos, Michigan

Bing Shi
Clinton Township, Michigan

Meijer
Corporate Sponsors

Randy Brower
Grand Rapids, Michigan

James Poll
Grand Rapids, Michigan

David Rodgers
Grand Rapids, Michigan

MOTOROLA

MOBILE USER GENERATED VIDEO SERVICE

From a son's first steps to a daughter's wedding day, home videos help us capture our most important memories so we can share them with our closest family and friends.

It is convenient to share videos through online applications for some generations, but not for all. However, it is easy to turn on a television set, and navigate and watch cable; generations have been doing this for years.

Motorola's Mobile User Generated Video Service has combined the convenience of an online application with the ease of cable television. Once created, a user generated video is uploaded to a central Video on Demand (VOD) server located at a cable headend where it is stored. The video is added to the appropriate customer's programming guide so it can be selected and streamed to the cable set top.

Users of the mobile application record a video with the camera on their phone, upload it, view it, give it a name and description, and associate buddies with it. Associating a buddy with a video gives them permission to view it on their cable set top box; they can easily turn on their television, navigate to the video they want to watch, click play, and the video is streamed from our server to their screen.

In addition, the developed VOD server can capture live television in the cable headend and make the captures available for cable users to view.

All services are programmed in Java and Objective-C, using a Glassfish application server, and a MySQL database.

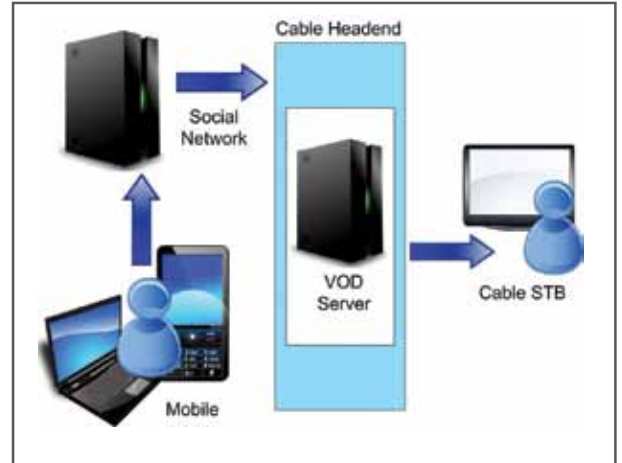

MOTOROLA



Michigan State University

Team Members (left to right)

Ryan Ley
Okemos, Michigan

Robert Palmer
Livonia, Michigan

Philip Deschaine
Haslett, Michigan

Mary Fetsco
Sterling Heights, Michigan

Motorola

Corporate Sponsors

Kabe Vanderbaan
Schaumburg, Illinois

TECHSMITH MICROSOFT TEAM SYSTEM CUSTOM CLIENT

Software development in a team environment has the advantage of allowing talented engineers to collaborate their ideas towards a common focus. This design methodology helps TechSmith create cutting edge screen capture and recording software designed to help people communicate.

Team collaboration does, however, present some technological hurdles. Developing software in a team environment, engineers must worry about version control, progress tracking, build management, process guidance, and business intelligence. Bringing all of this information together in an accessible form proves to be difficult for software development.

At the core of their software development processes, TechSmith uses Microsoft Team Foundation System to collect and track collaborative development data from multiple individuals on multiple teams. Team Foundation System does not however, allow users easy and intuitive access to the information it collects.

With the Team System Client, users can access all of this collaboration data from one convenient web portal. From their computer workstation, users can view and modify information for key elements of software projects that they are working on.

This website application is created as a Microsoft Silverlight front-end to a C# .NET web service that can interact with Microsoft Team Foundation System 2008.

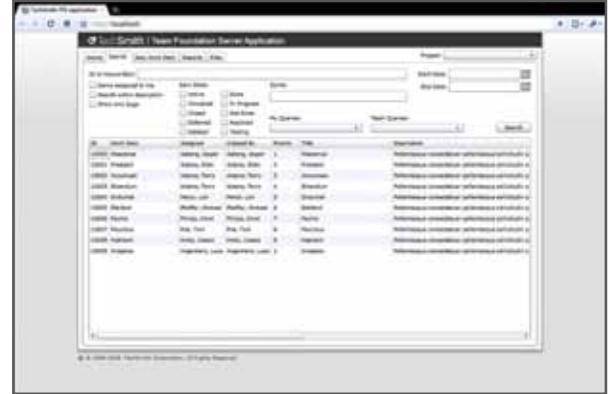

Michigan State University
Team Members (left to right)

Jonathan Anderson
Perry, Michigan

Eric Henry
Dewitt, Michigan

Paul Dziadzio
Wixom, Michigan

Daniel Laboy
Portage, Indiana

TechSmith
Corporate Sponsors

Dean Craven
Okemos, Michigan

Jim Dusseau
Okemos, Michigan

David Girdwood
Okemos, Michigan

THE TORO COMPANY

IRRIGATION DISTRIBUTION UNIFORMITY ANALYSIS

Recently, the study of climate change and the human impact on it has taken center stage in our everyday discussions. The Toro Company is taking a proactive role to minimize that impact as it relates to one of our most precious resources, water. Irrigation is a complex issue that involves balancing the type of sprinklers used and the way in which they are arranged. Toro constantly tests, measures and analyzes data collected from various sprinkler nozzles in an effort to evenly distribute water.

To help solve this problem, we have developed software that can take the information collected by Toro technicians and provide graphs and calculations in order to figure out the best solution.

The software works in two ways. In the automatic mode, the user can choose to look at only one sprinkler nozzle and select from one of several preset arrangements.

The software can also be used in a manual mode, which allows a person to look at several different sprinklers at the same time, moving them on a grid to whatever position they desire.

Both modes present the information as graphs known as densograms that illustrate the levels of water in an area by shading areas in various colors.

The Irrigation Distribution Uniformity Analysis tool is written in Visual C#, ASP.NET and Direct X.

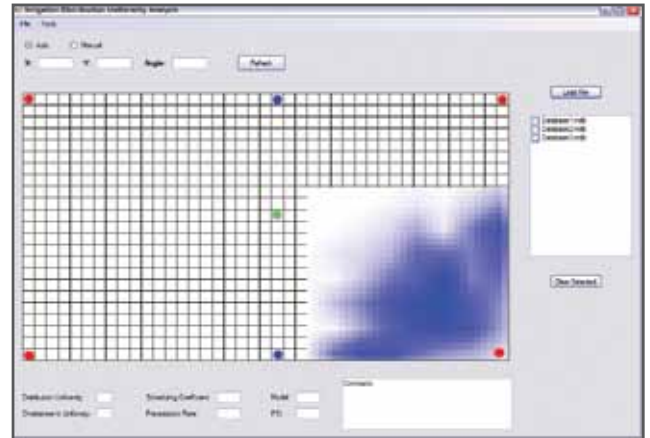

Count on it.



Michigan State University Team Members (left to right)

James Harrison
Troy, Michigan

Andrew Giannini
Lansing, Michigan

Brett Janer
Bay City, Michigan

The Toro Company Corporate Sponsors

Nathan Fujimoto
Riverside, California

Andy Strother
Riverside, California

URBAN SCIENCE AUTOMOBILE DEALERSHIP DASHBOARD

In evaluating all of the operations within a given automobile dealership, Urban Science provides several products that assess the performance and opportunity in different departments and activities. Given the current status of the automotive industry in struggling to maintain dealer profitability, products that give dealers insight into their operations have become more vital.

The Automobile Dealership Dashboard was created to provide this key information in a very effective and timely manner. This is important given the limited amount of time dealer management has to make decisions regarding this information.

The dashboard uses various charts, graphs, gauges, and data tables to display important information to not only specific automobile dealerships, but also to Original Equipment Manufacturers such as Ford, Chrysler, and General Motors.

Urban Science has developed several products that provide information on specific departments throughout an automobile dealership. The dashboard application acts as a portal by linking to these products via the Web to give users more information on what they are specifically looking for.

Usability and flexibility are two important factors in designing dashboard applications, which is why users of the Automobile Dealership Dashboard have the ability to customize pages to display the information they are interested in the most. This dashboard application was developed using C# and XAML along with a SQL Server 2005 database.



Michigan State University Team Members (left to right)

Sean O'Donnell-Daudlin
Gross Pointe, Michigan

Garrett Radford
Westland, Michigan

Michael Cybulski
Ortonville, Michigan

Urban Science Corporate Sponsors

Mark Colosimo
Detroit, Michigan

Jay Lytle
Detroit, Michigan

Suzanne DuBois
Detroit, Michigan

Computer Science and Engineering

Capstone Course Sponsors

We thank the following companies for their generous support of the computer science capstone course.

Auto-Owners Insurance Co.
Lansing, Michigan



The Boeing Company
St. Louis, Missouri



GE Aviation
Grand Rapids, Michigan



Meijer
Grand Rapids, Michigan



Motorola, Inc.
Schaumburg, Illinois



TechSmith Corporation
Okemos, Michigan



The Toro Company
Riverside, California



Urban Science
Detroit, Michigan





Prof. Goodman

ELECTRICAL AND COMPUTER ENGINEERING AND MECHANICAL ENGINEERING PROJECTS

PRESENTATION SCHEDULE — Lake Huron Room

Course Coordinators: Professors Erik Goodman and Craig W. Somerton

Faculty Advisors: Professors Ayres, Balasubramanian, Brereton, Brown, Deller, Mukherjee, Mukkamala, Reid-Bush, Ren, Shaw

Huron

8:00 – 12:30
Third Floor
Lake Huron Room

Time	Project Sponsor(s)	Sponsor Contact(s)	Faculty Advisor(s)	Project Title
8:00 ECE 480	MSU RCPD	S. Blosser	R. Mukkamala	Body Temperature Regulator Vest for Quadraplegic Patient
8:25 ECE 480	Advanced MicroSystems and Circuits (AMSaC) Research Group	X. Liu	T. Brown	Low-cost Electrochemical Sensor
8:50 ECE 480	Texas Instruments	R. Hinkel P. Kimelman J. Reinhart	J. Ren	Power-over-ethernet for Wireless Home Automation
9:15 ECE 480	Norfolk Southern	H. Newell	J.R. Deller	Cracked Rail Spike Detector
9:40–10:00 Break				
10:00 ECE 480	Whirlpool	R. Jeffrey	V. Ayres	Lowering Standby Power Consumption via Proximity Detection
10:25 ECE 480	United States Air Force Research Laboratory	K. Scheel	S. Balasubramanian	Small, Lightweight Speed and Distance Sensor for Skiers and Snowboarders
10:50 ME 481	MidMichigan Medical Center	P. Essex	S. Shaw	Steering Design of the Push-pull Recumbent Cycle
11:15 ME 481	Sparrow Pediatric Rehabilitation Center	N. Bradley	T. Reid-Bush	Pediatric Exercise Equipment
11:40 ME 481	Sparrow Pediatric Rehabilitation Center	C. Humphrey	R. Mukherjee	Hands-free Gait Trainer

ECE 480 Senior Capstone Design

ECE 480 is required of all electrical engineering or computer engineering majors at MSU.

It prepares students for the workplace, or for graduate school, including:

- Putting into practice the technical skills learned in the classroom, on industrially sponsored team projects, under faculty guidance, doing open-ended design, giving them experience in teamwork, project management, product life cycle management, legal, intellectual property and accommodation issues, and in entrepreneurship.
- Polishing their communication skills – individual and team – on proposals, reports, resumes, evaluations, posters, web pages, and oral presentations.
- Requiring each student to complete four individual hardware/software laboratory assignments.

Team sponsors are local and national, including MSU Resource Center for Persons with Disabilities (Wochholz Endowment), Marathon Oil, MSU Advanced Microsystems/Controls Research Group, Texas Instruments, Norfolk Southern, Whirlpool, and the Air Force Research Laboratory

ECE 480 & ME 481 Engineering Design Projects

MSU RCPD: BODY TEMPERATURE REGULATOR VEST FOR QUADRIPLÉGIC PATIENT

One of the possible results of a spinal injury is a reduced ability to regulate one's body temperature. This problem can impair basic body functions in extreme weather. Last semester, in a combined effort with the *MSU Resource Center for Persons with Disabilities (RCPD)*, an ECE 480 team designed a jacket to control the temperature of an individual by heating or cooling water, using solid state devices, and sending it through a network of tubes lining the jacket. Utilizing this research, the next step, to be done by our team, is to make a design that is safer and more convenient for the consumer. There are a few key ways this can be achieved, including adding temperature and power safeguards, changing the design of the jacket with attention to comfort, and adding to the settings of the device. An automatic setting can be added to control the temperature by monitoring ambient and body temperatures, and an increase in the manual options will provide a wider range of comfort. The additional settings will require a new user interface to accommodate the series of options. These added system capabilities will add convenience and versatility to the system.



J. Davis
Electrical Eng



M. Nahoom
Computer Eng



C. Pline
Electrical Eng



J. Zaheer
Electrical Eng



R. Bouserhal
Electrical Eng

<http://www.egr.msu.edu/classes/ece480/goodman/spring09/group01>



Mr. Blosser



Prof. Mukkamala

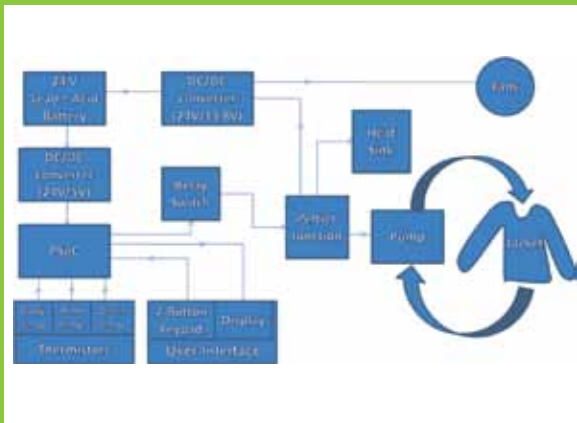

Project Sponsor
MSU Resource Center for Persons with Disabilities

Sponsor Representative
Mr. Steven Blosser

Faculty Facilitator
Dr. Ramakrishna Mukkamala

Team Members & Non-Technical Roles
Jarred Davis
Manager

Merav Nahoom
Webmaster

Christa Pline
Documentation Prep

Jawad Zaheer
Presentation Prep

Rachelle Bouserhal
Lab Coordinator

AMSaC RESEARCH GROUP: LOW-COST ELECTROCHEMICAL SENSOR

Early detection of tumor cells among healthy human cells is one of many problems in the medical industry that presents challenges both financially and technically. One possible solution to this problem is using the human body's cellular proteins as detectors. The MSU Advanced Microsystems and Circuits Research Group has tasked design team 2 with creating a system for characterizing cellular proteins. We are going to use modern analog components, microcontrollers, and computer data acquisition systems to perform low-cost electrochemical analysis. Our system will be capable of performing multiple electrochemical techniques including chronoamperometry, cyclic voltammetry, and low-frequency electrochemical impedance spectroscopy to determine the presence or state of proteins. This will accommodate a broad range of signal levels to suit a variety of usage scenarios. Such an instrument will be a great asset in advancing functional proteomics, which is important to improved scientific understandings of biological processes and future generations of drug and treatment options for adverse medical conditions and diseases. These tests are currently being done separately with existing lab equipment; unfortunately this equipment is extremely expensive. Our goal is to achieve this same functionality in one device at a significantly reduced cost.

<http://www.egr.msu.edu/classes/ece480/goodman/fall09/group02/>



L. LaPointe
Electrical /
Computer Eng



M. VanCamp
Electrical Eng



N. Timpf
Electrical /
Computer Eng



S. Zuraski
Electrical Eng



B. Woodman
Electrical Eng



Prof. Mason



Prof. Brown



Ms. Liu

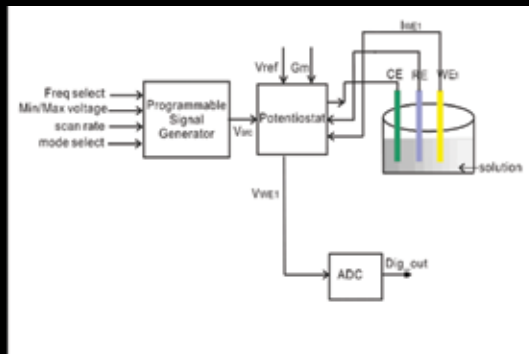

Project Sponsor
AMSaC Research
Group (MSU)

**Sponsor
Representative**
Dr. Andrew Mason
Ms. Xiaowen Liu

Faculty Facilitator
Dr. Terence Brown

**Team Members &
Non-Technical Roles**
Nick Timpf
Manager

Luke LaPointe
Webmaster

Mark Van Camp
Documentation Prep

Brent Woodman
Presentation Prep

Steve Zuraski
Lab Coordinator

TEXAS INSTRUMENTS: POWER-OVER-ETHERNET FOR WIRELESS HOME AUTOMATION

With steady increases in energy costs and the demand for low-power devices on the rise, engineers are now looking to tackle the situation with new innovative approaches. *Texas Instruments Inc.* has proposed a design to implement a Power-over-Ethernet (PoE)-enabled gateway to low-power monitoring devices. PoE is an effective mechanism to safely transfer power and data over long distances within a single cable. The intended application for this would be to power monitoring devices that interact with wireless sensors within range. To analyze sensor traffic, a web server will be connected within the network to provide ease of access and control. The use of low power wireless protocols is essential in maintaining efficient energy usage within all nodes of the network. These sensors could be of any application desired by the user, including monitoring devices used for building control, homeland security, medical instruments and agriculture. Using parts and packages from TI, the prototype provides an effective means for monitoring sensor activity as well as maintaining low cost and low power.

<http://www.egr.msu.edu/classes/ece480/goodman/fall09/group03/>



D. DeLuca
Computer Eng



H. Abdullahi
Electrical Eng



K. Hemmanur
Computer Eng



S. Balachandran
Computer Eng



Prof. Ren

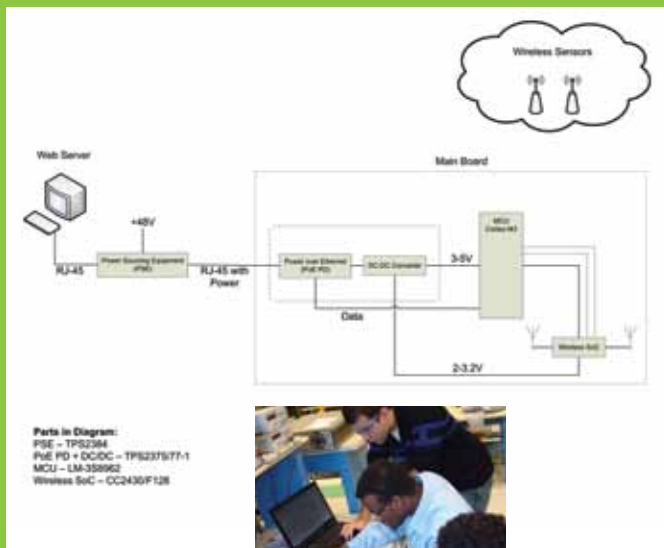

Project Sponsor
Texas Instruments

Sponsor Representatives

- Mr. Reed Hinkel
- Mr. Paul Kimelman
- Mr. Jim Reinhart

Faculty Facilitator
Dr. Jian Ren

Team Members & Non-Technical Roles

- Karthik Hemmanur
Manager
- Sasang Balachandran
Documentation Prep
- Hassan Abdullahi
Presentation Prep
- David DeLuca
Lab Coordinator

NORFOLK SOUTHERN: CRACKED RAIL SPIKE DETECTOR

Norfolk Southern Corp. has discovered a problem with rail spikes failing under the stress of freight trains. Once a spike has broken all the way through, the top part is easily removed, however, the lower part must be driven through the tie, causing the replacement spike to have a loose fit. The sponsor wants an ergonomic, lightweight device that will detect a cracked or broken spike. It is also necessary to weatherproof the device for the wide variety of environments Norfolk Southern Corp. operates across. The proposed method of detecting is an ultrasonic device. An ultrasonic wave is directed at the spike; any edges from cracks or the shape of the spike will send a return. Testing in the device will consist of filtering the frequency range of the return signals then measuring the amplitude and time of the return signals. Once the signals are processed the device will indicate whether the spike is defective.

Our device will feature the following:

- Ultrasonic transducer
- Analog filter
- Threshold detector
- Couplant capsule
- LED and buzzer indicator

www.egr.msu.edu/classes/ece480/goodman/spring09/group04



C. Church
Electrical Eng



G. Brigham
Computer Eng



R. Fox
Electrical Eng



M. Hamm
Electrical Eng



J. Vogel
Computer Eng



Mr. Newell



Prof. Deller

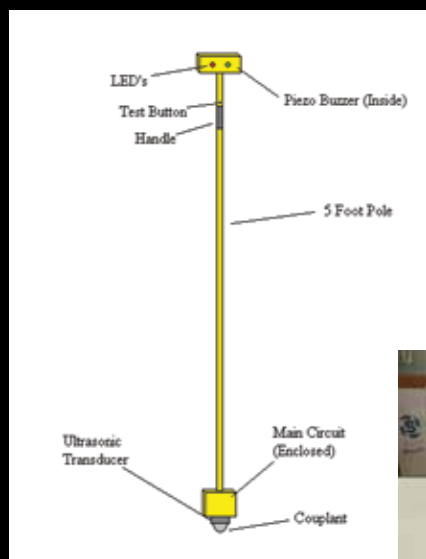

Project Sponsor
Norfolk Southern Corp.

Sponsor Representative
Mr. Hayden Newell

Faculty Facilitator
Dr. J.R. Deller

Team Members & Non-Technical Roles

Chad Church
Manager

Ronald Fox
Webmaster

John Vogel
Documentation Prep

Geoff Brigham
Presentation Prep

Matt Hamm
Lab Coordinator

WHIRLPOOL: LOWERING STANDBY POWER CONSUMPTION VIA PROXIMITY DETECTION

The Whirlpool Corporation has anticipated new guidelines from the Environmental Protection Agency and the United States Department of Energy’s ENERGY STAR that require home appliances to enter a stand-by mode and consume 1 Watt of power or less. The design goal is to improve home appliances to be more power efficient and environmentally friendly while maintaining their functionality for the customer experience. The team will use an infrared sensor and develop a device that can smoothly enter and exit an energy ethical stand-by mode that will lower energy consumption. When this device detects user presence within a specified range, it will remove the appliance from stand-by mode to prepare it for regular use. The choice of the appropriate sensing device scheme will depend on the price range of the appliance. For this reason, the team will develop a device for low-to- mid-range products that will take the appliance out of stand-by mode and return it to regular use, and will also develop a device for high-end products that can calculate user proximity and increase the information density of a user interface panel. The overall scope of the project, however, is to lower energy consumption while enhancing the user experience. When you walk into your kitchen, your kitchen should turn on. The picture below shows the team working with the infrared sensor to determine its compatibility with the provided microprocessor.



K. Harrison
Electrical Eng



L. Hodges
Electrical Eng



E. Hosey
Computer Eng



N. Kelly
Electrical Eng



B. Saracoglu
Electrical Eng



<http://www.egr.msu.edu/classes/ece480/goodman/spring09/group05>



Mr. Jeffery



Prof. Ayres

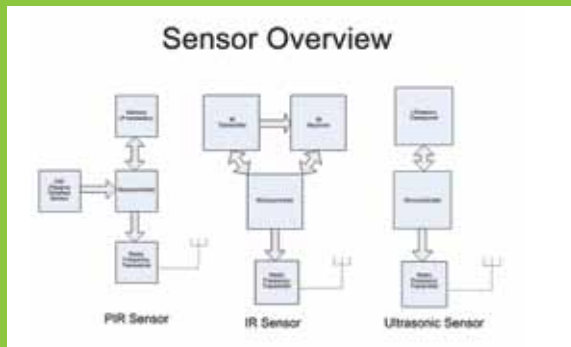

Project Sponsor
Whirlpool Corporation

Eric Hosey
Webmaster

Sponsor Representative
Mr. Randy Jeffery

Kevin Harrison
Documentation Prep

Faculty Facilitator
Dr. Virginia Ayres

Leslie Hodges
Presentation Prep

Team Members & Non-Technical Roles
Berna Saracoglu
Manager

Nathan Kelly
Lab Coordinator

UNITED STATES AIR FORCE RESEARCH LABORATORY: SMALL, LIGHTWEIGHT SPEED AND DISTANCE SENSOR FOR SKIERS AND SNOWBOARDERS

The goal of many competitive sports is to complete a track or course faster than the competition. Practicing for such sports often involves tracking one's performance, which can be difficult for winter sports due to the lack of measurable motion. Therefore, with the help of the *Air Force Research Lab*, Team Six has designed a lightweight speed and distance sensor that can be used by skiers or snowboarders. This project is being entered into a competition among universities for sponsorship as a capstone design project by USAFRL.

This sensor allows users to track their progress by recording their top speed, total distance traveled, and other measures of performance. The team accomplished this by integrating a Global Positioning System (GPS) and an inertial navigation system (INS). The GPS will be used to reset the INS and minimize error, while the INS has the ability to determine erroneous GPS readings. The robustness of this design provides the user with accurate, meaningful, and useful data. The user can view the data on the LCD after a run, or review it later on a PC using USB. For both professional and winter sports enthusiasts, this device can provide an invaluable edge over the competition.

<http://www.egr.msu.edu/classes/ece480/goodman/fall09/group06/>



M. Bekkala
Electrical Eng



M. Blair
Computer Eng



M. Carpenter
Computer Eng



M. Guibord
Computer Eng



A. Parvataneni
Computer Eng



Dr. Balasubramaniam

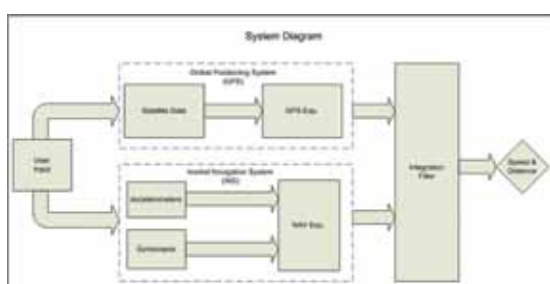

Project Sponsor
US Air Force Research
Laboratory

**Sponsor
Representative**
Mr. Kevin Scheel

Faculty Facilitator
Dr. Shanker
Balasubramaniam

**Team Members &
Non-Technical Roles**

Michael Blair
Manager

Matthew Guibord
Webmaster

Michael Bekkala
Documentation Prep

Abhinav Parvataneni
Presentation Prep

Michael Carpenter
Lab Coordinator

MIDMICHIGAN MEDICAL CENTER: STEERING DESIGN OF THE PUSH-PULL RECUMBENT CYCLE

Many patients with neurological disorders, such as cerebral palsy, have difficulty getting exercise. Since their joints and muscles do not always function over the full range of motion, specialized equipment is needed for these patients to exercise their muscles. One of these systems is the NuStep, a stationary exercise machine that uses a “push-pull” system. The patient alternately pushes with one arm and the opposite leg, and then the other arm and leg.

At *MidMichigan Medical Center*, the physical therapy department wanted to create a system that provided the exercise of the NuStep system, while also including mobility. This mobility would provide patients with a sense of freedom and independence, which would be of a significant psychological benefit.

Two different ME 481 teams have worked with *MidMichigan Medical Center* in the past in order to address this challenge. The previous team successfully incorporated the “push-pull” propulsion into a mobile machine but was unable to include a steering system.

There are many requirements for this project. In addition to including mobility and steering, the system had to be fairly lightweight and efficient. It needed to accommodate patients with a wide variety of muscle conditions, and a wide range of ages and sizes as well.

In order to meet the requirements of weight and maneuverability, we chose to use a recumbent tricycle, provided by TerraTrike, as the frame for our design. Using the drive mechanisms of the NuStep combined with electric steering, we were able to provide the patient with freedom of motion as well as physical exercise.

...*The MidMichigan Medical Center Student Design Team*



Transforming Lives™



Ms. Essex

The current stationary bike provides cardiovascular strengthening and range of motion for patients of all ages. By making it mobile, the patients will be able to engage in the community, independently or along with family members, and enjoy the bike as a recreational exercise. Moreover, this activity would provide them with the necessary therapeutic benefits.



Prof. Shaw

Peggy Essex
Physical Therapy Assistant
MidMichigan Medical Center

Project Sponsor
MidMichigan Medical Center

Midland, Michigan

Professional Advisor

Ms. Peggy Essex

Faculty Advisor

Prof. Steven Shaw

Team Members and Home Towns

Allen Eyler
Ann Arbor, Michigan

Stephen Hammack
Howell, Michigan

Phillip Marino
Macomb, Michigan

Marissa Wiltz
Milford, Michigan

SPARROW PEDIATRIC REHABILITATION CENTER: PEDIATRIC EXERCISE EQUIPMENT

The *Sparrow Pediatric Rehabilitation Center* is a department of the Sparrow Health System's Regional Children's Center. Located in Lansing, Michigan, this center provides physical therapy, occupational therapy, and speech-language pathology services for inpatients and outpatients. The *Rehabilitation Center's* overall mission is to provide comprehensive, accessible, and compassionate rehabilitation services. The center's governing values for care include excellence, service, people, responsibility, innovation, and teamwork.

Outpatient physical therapy assists in reinforcing and developing gross motor skills, such as walking, running or climbing. Focus can also be on promoting improvements in strength, flexibility, balance, or coordination. Children can require physical therapy as a result of injury, illness, or developmental disability. Physical therapy for these patients can be a short-term or a lifelong process. There is a need for more exciting and engaging physical therapy equipment geared toward pediatric rehabilitation.

The project proposed by the *Sparrow Pediatric Rehabilitation Center* was to design and construct a pediatric exerciser that motivates children to reach their rehabilitation goals, while providing patients with a sense of fun and enthusiasm during their physical therapy sessions. The target audience consisted of patients aged four to ten years, with varying anthropometrics and muscular abilities.

This task was accomplished by developing several design concepts balancing effective physical therapy with engaging stimulation. The final exerciser was designed to focus on targeting both the upper and lower extremities of the patient, while integrating a fun factor. To meet this challenge,



a recumbent cycle for the legs and an arm rowing motion inside a child-friendly car was designed. While the fun factor included the aesthetically-pleasing car design, the continuous physical activity of the patient was rewarded with simulated car motion and visual feedback.

...*The Sparrow Pediatric Rehabilitation Center Student Design Team*



Ms. Bradley



Prof. Reid-Bush

Exercise is an integral part of any physical rehabilitation program. In the area of pediatric rehabilitation, children must often adhere to exercise programs over a course of weeks, months, or sometimes years, in order to achieve their goals. Maintaining motivation and compliance throughout this process can be challenging. The development of a piece of pediatric exercise equipment that motivates children to reach their rehabilitation goals, while maintaining a sense of fun and enthusiasm, will enhance individual progress and will improve the overall effectiveness of each child's rehabilitation program.

Nancy Bradley, PT
Physical Therapist
Sparrow Pediatric Rehabilitation Center

Project Sponsor
Sparrow Pediatric Rehabilitation Center
Lansing, Michigan

Professional Advisor
Ms. Nancy Bradley, PT

Faculty Advisor
Prof. Tamara Reid-Bush

Team Members and Home Towns
Chris Cater
Grand Rapids, Michigan

Kunjan Patel
Canton, Michigan

Kelly Peterson
Walled Lake, Michigan

Eva Reiter
Haslett, Michigan

SPARROW PEDIATRIC REHABILITATION CENTER: HANDS-FREE GAIT TRAINER

Sparrow Pediatric Rehabilitation Department is an integral part of Sparrow Health System’s Regional Children’s Center. They offer services in physical therapy, occupational therapy, and speech-language pathology. The mission of the Pediatric Rehabilitation Department is to provide compassionate, complete, and accessible rehabilitation services to the children of mid-Michigan and their families. The hope is that, through coordinated help from the rehabilitation team and patients, children can achieve a quick recovery and eventually a high level of independence in their lives.

The objective of the project is to design and build a hands-free gait trainer. The Pediatric Rehabilitation Center will be using the device to help improve the gait of preschool children. The device must be easy to use, portable, and lightweight. The Pediatric Center works with both inpatients and outpatients and that is why the device needs to be portable. Patients might be using the device at home; therefore, it should be easily collapsible and lightweight so that it can be easily transported between the hospital and home.

Currently Sparrow uses walkers or a two-parallel bar system in the effort to help patients relearn their gait. The hands-free gait trainer is made of hollow aluminum and ensures that patients will not have to use their hands. The usage of hollow aluminum bars provides adequate structural support, while offering a lightweight design. The hands-free gait trainer is adjustable, to accommodate use for patients in the 2-6 year age group, regardless of height or weight. Research on the range of height and weight of children in this age group was completed to ensure that the gait trainer can adequately support the patient’s weight, while still functioning properly.

...The Sparrow Pediatric Rehabilitation Center Student Design Team



Ms. Humphrey

The hands-free gait trainer will provide a new product to rehabilitation centers that will produce a higher quality of rehabilitation, or perhaps faster recovery. This gait trainer will help provide another vital piece of equipment to aid in the training of a young individual’s gait.

Catriona Humphrey, PT
Physical Therapist
Sparrow Pediatric Rehabilitation Center



Prof. Mukherjee

Project Sponsor
Sparrow Pediatric
Rehabilitation Center
Lansing, Michigan

**Professional
Advisor**
Ms. Catriona
Humphrey, PT

Faculty Advisor
Prof. Ranjan Mukherjee

**Team Members
and Home Towns**
Joe Brent
Rochester Hills, Michigan

Chris Ezop
Dansville, Michigan

Mathieu Rich
Midland, Michigan

Case Vandenkieboom
Waterford, Michigan

FORD MOTOR COMPANY: REFUELING EFFECTS OF FLUID FLOW BEHAVIOR IN FUEL PUMP NOZZLES

Ford Motor Company is committed to maintaining excellence in all aspects of their vehicle design. This means constantly working to improve their product to increase customer satisfaction through various methods, including rigorous testing. Customer concerns are important to consider, and one aspect of these concerns is the refueling of the vehicle at one of the many gas stations available today on the road. Ford seeks to improve the performance of the vehicles with the many different types of refueling apparatus on the market today.

The interaction of fueling nozzles with the filler line and fuel tank is something that everyone who has driven a car has experienced. The shutoff of a fueling nozzle is a complex process that varies from nozzle to nozzle. Some nozzles tend to work better with certain vehicles than others; therefore it is important for Ford to identify the differences in these nozzles that cause varied performance.

Experiments were conducted to ascertain the nature of fluid flow through four different nozzles and other characteristics that may affect shutoff, using facilities located at Michigan State University. Computational models were also employed in conjunction with experimental data to obtain a more detailed understanding of nozzle behavior.

...The Ford Motor Company Student Design Team

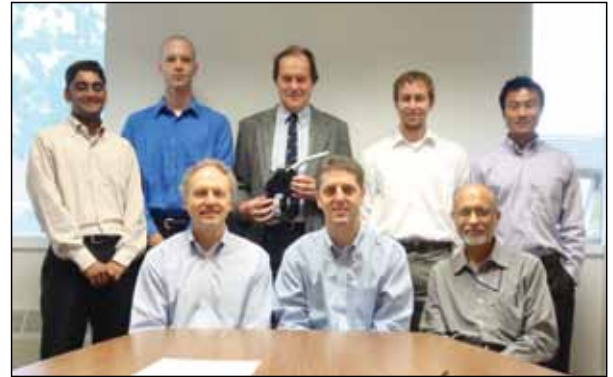

Mr. Bramson



Prof. Brereton

Common problems encountered during the refueling development process are nuisance shutoffs of the pump, spills, and emission of gasoline vapor. A better understanding of the fluid flow performance of the various pump nozzles will help create better automobiles with fewer refueling problems and allow faster product development times at lower cost. It will also promote a healthier environment, improved customer satisfaction, and a better image of Ford and its vehicles.

Eric Bramson
Ford Motor Company

Project Sponsor
Ford Motor Company
Dearborn, Michigan

Professional Advisors
Syed Ali
Eric Bramson
Rob Pyle
Mike Wene
Yi Zhang

Faculty Advisor
Prof. Giles Brereton

Team Members and Home Towns
Harold Black
St. Louis, Missouri

Tim Francisco
Livonia, Michigan
Shang Shi
Grand Rapids, Michigan
Krishna Vistarakula
Haslett, Michigan

CE 495

8:00 – 12:00
MSU and Lake
Michigan Rooms

CE 495 Design Engineering Project

CE 495 SENIOR DESIGN IN CIVIL ENGINEERING

FACULTY ADVISORS: Professors Baladi, Chatti, Hatfield (emeritus), Maleck, Masten and Wallace



Baladi



Chatti



Hatfield
(emeritus)



Maleck



Masten



Wallace

In this one semester, required course, five student-teams have developed preliminary designs for a new rail/bus transportation facility on the west side of MSU's main campus. The facility will include a rail/bus station, access roads, parking, and storm water facilities; to accomplish the development contaminated materials located on the site must be disposed of safely. The station will be housed in the lower level of a new multistory building that will be located between Harrison Rd. and Farm Lane. The station platform must be at least 500 feet long and located so that passenger trains do not stop traffic on Harrison Rd. Engineering designs have been developed for the geometric layout of the roads, the structure of the building that will house the station, the soils that support the building, the on-site storm water management facilities, the pavement cross sections of the roads and parking areas, and a plan has been to insure safe removal and disposal of the contaminated materials currently located on-site.

PROFESSIONAL EVALUATORS

Christopher R. Byrum, Ph.D., PE
Soil & Materials Engineers
Plymouth, MI

Matt Junak, PE
HNTB
E. Lansing MI

Michael J. Thelen, PE
Soil & Materials Engineers, Inc.
Lansing, MI

Rick Chelotti, PE
Bergman Associates
Lansing, MI

Jesse Kolb, PE
NTH Consultants
Northville, MI

Phil Vogelsang, PE
URS Corporation
Grand Rapids, MI

Daniel Christian, PE
Tetra Tech MPS
Lansing, MI

John LeFevre, PE
FTCH, Inc.
Lansing, MI

Jim Corsiglia, PE
Harley Ellis Devereaux
Southfield, MI

George McKenzie, PE
NTH Consultants
Lansing, MI

Sean Godin, PE
Desai/Nasr Consulting Engrs
West Bloomfield, MI

John Saller, PE
Wilcox Prof. Services, LLC
Lansing, MI

Daniel Starkey, PE
Earth Tech Inc
Grand Rapids, MI

**Award
Sponsors**

BARR

ftc&h

CE 495 SENIOR DESIGN IN CIVIL ENGINEERING

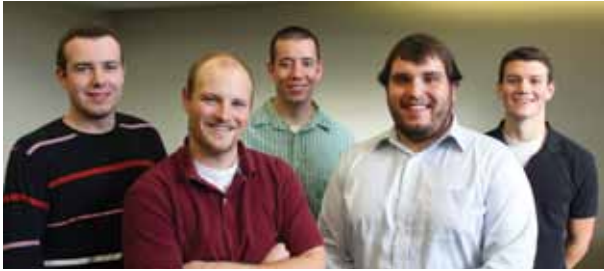

Team 1: Back, l-r: Alexey Orlov, Nick Bassett, Jon Libby
Front, l-r: Paul Spitzley, Danny Nichols. *Not present:* John Carter



Team 2: L-r: Paul Zeller, Ian Gulbis, Steven Russo, Jeff Schaeffer,
Jennifer Kaluarachchige, Travis Dunny, Benjamin Jenks

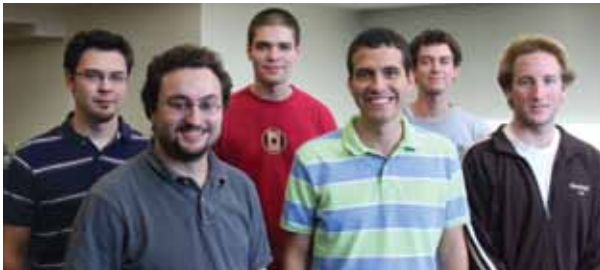

Team 3: Back, l-r: AJ Cardinale, Joseph Blauwiekel, Neil O'Brien
Front, l-r: Joshua Fink, Peter Blumberg, Clinton LaFayette



Team 4: L-r: Matt Aspinall, Matthew Brush, Ben Panepucci,
Kendal Vettrano, Joseph Primeau
Not present: Matthew Chaperon, Amirthan Ganesan



Team 5: Back, l-r: Derek Perry, Justin Sand, Michael Lynett
Front, l-r: Lauren Fedak, Kyle Korson, Pablo Castellon

TEAM	TIME	ROOM
1	8:00 a.m.	MSU Room
2	8:00 a.m.	Lake Michigan Room
3	9:20 a.m.	MSU Room
4	9:20 a.m.	Lake Michigan Room
5	10:40 a.m.	MSU Room

CE 495 Senior Design in Civil Engineering

All undergraduates pursuing BS degrees in civil engineering must take CE 495. This course prepares students for the work place by providing a team based, transitional capstone experience with many challenges that civil engineers face in the design/consult business:

- Participation in an engineering project with multiple issues that must be resolved using knowledge from six specialty areas of civil engineering;
- Formulation of specific conceptual solutions to the issues and resolution of conflicting design elements in the project;
- Development of preliminary plans that comply with government regulations and standards, and provide a basis for initial cost estimates;

- Assuming individual responsibility in a team based effort;
- Preparation of written reports for technical and non-technical audiences; and preparation of oral presentations.

Engineers and scientists from the following Michigan firms currently donate their time to provide students with the perspective of practicing professionals: Bergmann Associates; Desai/Nasr Consulting Engrs; Earth Tech Inc; Fishbeck, Thompson, Carr & Huber; HNTB; Harley Ellis Devereaux; NTH Consultants; Soil & Materials Engineers; Tetra Tech MPS; URS Corporation; and Wilcox Professional Services. We gratefully acknowledge their generous contribution.



REMEMBER WHEN YOUR CAREER CHOSE YOU?

FINDING SOMETHING YOU'RE PASSIONATE ABOUT doesn't happen every day, so when you do find it, you embrace it. At Boeing, we believe passion is what fuels our innovations and inspires our employees to be more than they ever thought possible. As we continue on our journey to amazing destinations, we want you to help take us there. You'll be joining an organization known for its support of learning both on and off the job, and one that has also been honored as higher education's top corporate sponsor. The job categories below include some of the key skills we are seeking.

- Aeronautical Engineering
- Aerospace Engineering
- Business/Finance
- Chemical Engineering
- Civil Engineering
- Electrical Engineering
- Electromagnetic Engineering
- Embedded Software Engineering
- Industrial Engineering
- Manufacturing Engineering
- Material Science Engineering
- Mechanical Engineering
- Optics
- Payloads
- Physics/Math
- Propulsion
- Reliability Maintainability
Testability Engineering
- Software Engineering
- Structures
- Systems Engineering

To view a comprehensive listing of all available positions, please visit: boeing.com/collegecareers
Security clearance requirements are indicated in the position listings. U.S. citizenship is necessary for all positions requiring a security clearance.

Boeing is an equal opportunity employer supporting diversity in the workplace.

Apply at: boeing.com/collegecareers





TO SEE CHEMISTRY THROUGH THE EYES OF

HUMANITY IS TO SEE THE PROMISE OF A BETTER

FUTURE. That's the power of the Human



Element. The Dow Chemical Company proudly

supports MSU College of Engineering's Design

Day and the hope for the future it represents.

ChE 434 MSE 466

Course
Information



Prof. Hawley

CHE 434: SENIOR DESIGN COURSE IN CHEMICAL ENGINEERING

Senior chemical engineering students are experienced in making many of the calculations that go into the design of industrial manufacturing plants. Pipe sizes, heat transfer areas, number of plates and diameters of distillation columns, chemical reactor sizes, compressor horsepower, etc. are all familiar answers to chemical engineering course problems. There are, however, some important differences between designing a plant, part of a plant, or even a single piece of equipment in an industrial situation and solving a college class problem. For the 40th successive year, students worked the American Institute of Chemical Engineers (AIChE) Student Contest Problem. While this may sound like the name of some sort of game, we must note that industrial companies have put hundreds of thousands of dollars worth of engineering time into developing and evaluating these problems. MSU Chemical Engineering has the best record in the nation for placing in this national contest since 1967! Last Spring for Design Day, selected ChE 434 students presented their design for a plant to use corn as a feedstock to produce 50 million US gallons of fuel-grade butanol, along with other corresponding products. Another exciting AIChE problem will be presented by this year's ChE seniors next Spring!



Prof. Lucas

MSE 466: SENIOR CAPSTONE IN MATERIALS SCIENCE AND ENGINEERING

A major objective of this course is to have students apply their courses background and skills in materials science to real-life design problems. Failures are a major motivating force for generating innovative designs or design changes. A failure analysis investigation provides a unique platform to design and solve a real-world engineering problem, systematically. By focusing on a specific design failure, the student teams face an open-ended problem that requires them to design a strategy plan and execute the methodology for assessing how and why the design failure occurred. The analysis is conducted using established investigative procedures and constraints for conducting failure analysis investigation. Last Spring for Design Day, MSE 466 students presented their projects including fracture of a main drive gear, failure of a Salisbury differential front output shaft, cracking of a Ni-based alloy bushing, bolt fracture used in a 240 ton mechanical press, and fracture of a Ni-Alloy/C-22 chlorine compressor shaft. Look for MSE 466 projects at Spring 2010 Design Day!

For the first time, the Department of Chemical Engineering and Materials Science participated in Design Day in Spring 2009! Students from two capstone courses presented posters detailing their senior projects. We look forward to participating again next Spring!



ChE 434 students presented their posters at Design Day in May 2009



MSE 466 students presented their posters at Design Day in May 2009



Prof. Somerton

MECHANICAL ENGINEERING PROJECTS

PRESENTATION SCHEDULE — Lake Superior Room

Course Coordinator: Professor Craig W. Somerton

Faculty Advisors: Professors Bénard, Engeda, Hong, Loos, Mueller, Patterson, Pence, Somerton

Time	Project Sponsor(s)	Sponsor Contact(s)	Faculty Advisor	Project Title
8:00 ME 481	NatGasCar Co.	B. Trembath	A. Engeda	Natural Gas Drying System for CNG Vehicle Refuelling Appliance
8:25 ME 481	Shell Oil and Heartwood School	M. O'Brien	A. Loos	Bus Step Simulator
8:50 ME 481	Airmaster	R. LaZebnik R. Stone	A. Loos	Development of a New Fan for the Retail Market
9:15 ME 481	General Motors	C. Giovanardi D. Hagman T. Skowronski	A. Loos	Upper Reveal Molding and Appliqué System for Applied Door Window Frame Construction
9:40–10:00 Break				
10:00 ME 481	General Motors	M. Ply J. Rich	S. Hong	Re-design of the Cadillac Tail Lamp Locating Strategy for Variation
10:25 ME 481	Louis Padnos Iron & Metal Co.	A. Forrester M. Przekadzinski C. Schrotenboer	A. Bénard	Geothermal Replacement of a Conventional Chiller
10:50 ME 481	Green Vortex	I. Wichman	N. Mueller	Two-flush Toilet System
11:15 ME 481	Motorola	J. Wojack	E. Patterson	Mobile Device with a Flexible Display
11:40 ME 481	Woodcreek Elementary School and the Motorola Foundation	D. Graham	C. Somerton	Biomass Energy Demonstrator for Woodcreek Elementary School
12:05 ME 481	Lefevre Corporation	M. Lefevre	T. Pence	Redesign of Granulator Blades

ME 481 Mechanical Engineering Design Projects

ME481 is required for all mechanical engineering majors at MSU. The course provides students with a team-based capstone design experience:

- Using the technical expertise, communication skills, and teaming methodologies they have learned throughout their mechanical engineering curriculum, along with their creativity, to solve real world problems.
- Collaborating with practicing engineers to address problems sponsored by industry.
- Developing new products or re-designing existing products to reduce costs or enhance reliability.

- Interacting with large, medium-sized, and small companies involved in orthodontic devices, furniture, aerospace structures, automotive parts, consumer electronics, materials recycling, food processing, and machine tools.

Other projects are humanitarian based, in which the students work with individuals who have special challenges.

Project sponsors include Airmaster Fan, Ford Motor Company, General Motors Company, Green Vortex, Lefevre Corporation, Louis Padnos Iron & Metal Company, MidMichigan Medical Center, Motorola, Motorola Foundation, NatGasCar LLC, Shell Oil Company, and Sparrow Pediatric Rehabilitation Center.

NATGASCAR LLC: NATURAL GAS DRYING SYSTEM FOR CNG VEHICLE REFUELING APPLIANCE

NatGasCar Company is part of the Dan T. Moore Company portfolio. Dan T. Moore Co. has a proven track record of fostering R&D projects that produce results and products that transform an industry. NatGasCar Co. is a necessary and critical complement to that strategy by being the fastest and least expensive way to get the existing US car fleet off gasoline and onto a cheaper, cleaner fuel, compressed natural gas (CNG).

Natural gas from a domestic line enters the CNG compressor unit and is then pumped into the vehicle storage tank. Because home natural gas is “wet,” water collects in the refueling tip attached to the vehicle’s CNG cylinder during this process. If the exterior temperature in the garage drops below the freezing point during the refueling process, the water accumulated in the refueling tip freezes the CNG fueling line to the vehicle, making it impossible to disconnect for use of the vehicle.

The project task was to design, develop, and prototype a natural gas drying system necessary for a garage- or home- mounted vehicle refueling appliance (VRA). This system is one of the many sub-components that must be developed for the VRA to be a safe and reliable home appliance.

...The NatGasCar Student Design Team



Mr. Trembath

The *Natural Gas Drying System* for CNG Vehicle Refueling Appliance will help the NatGasCar LLC develop and engineer a solution for the removal of water inherent in residential natural gas. This system will require the MSU Engineering Team to develop a system to remove water from gas without venting natural gas to the environment. This is no easy challenge, but one that must be solved, for our organization to succeed in the marketplace and provide a reliable and cost effective product to the consumer.

Mr. Brad Trembath
NatGasCar LLC



Prof. Engeda

Project Sponsor
NatGasCar LLC
Brighton, Michigan

Professional Advisor
Mr. Bradley Trembath

Faculty Advisor
Prof. Abraham Engeda

Team Members and Home Towns
Jeffrey Laforge
Brighton, Michigan

Chris Meyers
Lansing, Michigan

Mackenzie Schmidt
Grosse Pointe, Michigan

A SHELL OIL COMPANY CHILDREN’S HUMANITARIAN PROJECT: BUS STEP SIMULATOR FOR HEARTWOOD SCHOOL

Hearthwood School is an educational provider servicing students with physical and cognitive disabilities, and autism spectrum disorders. Heartwood works with Mobility Opportunities Via Education (MOVE), a research based program that helps individuals with disabilities acquire more independence in sitting, standing, and walking. Heartwood School’s goal is to provide their students with opportunities and resources to practice motor skills that will help them be able to actively participate in the community.

The project, funded by Shell Oil Company, will provide an additional resource to aid students in meeting the goals of the MOVE program. The purpose was to design, build and test a bus step simulator for implementation at Heartwood School. Physical therapists will employ the simulator in lesson plans for students to help them build strength. This strength will not only assist the students in their daily task of getting on and off the bus for school, but will also give them confidence in their abilities for future bus interactions following their time at Heartwood School. This increase in overall student independence is the ultimate objective and aligns with the goals of Heartwood School.

Working through multiple designs, the team manufactured a functional bus step simulator. The final design required the consideration of many factors. Some of the most important factors were ease of operation, maintenance, mobility, size, safety, and student engagement and motivation.

...The Heartwood School Student Design Team



Ms. O'Brien

The project will enhance the educational day of physically impaired students by increasing abilities to functionally mobilize and decreasing the burden of care for families and other care providers. These increased abilities also bring new opportunities for fuller participation and involvement in family life, school life, and integration and inclusion in the wider community. The ability to climb up and down bus steps will allow this special population the opportunity to utilize public transportation.

Marcia O'Brien
Principal
Heartwood School



Prof. Loos

Project Sponsor
Heartwood School
Mason, Michigan

Professional Advisor
Ms. Marcia O'Brien

Faculty Advisor
Prof. Alfred Loos

Team Members and Home Towns
Michael Karoub
Dearborn, Michigan

Joshua Samp
Grand Rapids, Michigan

Thomas Theisen
Benton Harbor, Michigan

Ryan Wood
Mt. Pleasant, Michigan

AIRMASTER FAN COMPANY: DEVELOPMENT OF A NEW FAN FOR THE RETAIL MARKET

Airmaster Fan Company started as the Diehl Fan Company in 1886. Diehl was the first company to patent an electric fan and offered a wide variety of products to the general public. From the early- to mid-1900s, Airmaster acquired several operational companies such as Chelsea, Brundage, and Power Line Fan which would merge into one business unit in 2002.

Today *Airmaster* has grown to an international supplier of fans mainly focusing on the commercial and industrial markets. The headquarters, which is based in Jackson, MI, is equipped with a full engineering staff, testing laboratory, metal fabrication shop, and tool and die equipment. From this location, the finished product is shipped either directly to the customer or to their other warehouses across the United States.

With a majority of the business coming from industrial fans, *Airmaster* has developed a limited product line for the retail market. This project aims to develop new fans to compete in the retail market. Characteristics such as aesthetics, noise radiation, efficiency, and green design are the focus of the product. Also, the fan must adhere to the safety regulations set by the Occupational Safety and Health Administration as well the Underwriters Laboratory. With a new product line, *Airmaster* targets an additional ten million dollars in revenues through the year 2011. A working prototype, manufacturing plan, marketing approach, and future plans for design expansion will be developed. We would like to thank *Airmaster* for the rewarding learning experience and utmost support in the creative design process.



...*The Airmaster Fan Company Student Design Team*



Mr. Stone



Mr. LaZebnik

There is an opportunity in the market place for new business that would lead to profitable growth. Our target is to add \$10 million in revenue by the year 2011 through new product introductions.

Robert LaZebnik
Airmaster Fan Company

Project Sponsor
Airmaster Fan Company
Jackson, Michigan

Professional Advisors
Mr. Robert LaZebnik
Mr. Richard Stone

Faculty Advisor
Prof. Alfred Loos

Team Members and Home Towns
Brittany Haberstroh
Farmington Hills, Michigan

Derek Mayoros
Trenton, Michigan

Ankita Patel
Lansing, Michigan

Syed Saleem
Karachi, Pakistan



Prof. Loos

GENERAL MOTORS COMPANY: UPPER REVEAL MOLDING AND APPLIQUÉ SYSTEM FOR APPLIED DOOR WINDOW FRAME CONSTRUCTION

General Motors is one of the world's largest automakers, having manufacturing operations in 34 countries. With its global headquarters in Detroit, Michigan, *General Motors* employs people in every major region of the world, as well as sells and services vehicles in over 140 countries. Cadillac, which specializes in performance luxury vehicles, is the prestige division of *General Motors*. Cadillac has obtained this reputation through innovative engineering and focusing on quality, performance, aesthetics, functionality, safety, and reliability to guarantee customer satisfaction.

Automotive design requires the marriage of aesthetics and functionality to produce the best product possible. As an example, exterior molding must not only accentuate a vehicle's lines and appearance, but must also be designed to reduce noise and to stand up to the elements presented by a variety of operating conditions throughout the lifespan of the vehicle.

The goal of this project was to develop an aesthetically pleasing B-pillar appliqué and upper reveal molding system for the Cadillac CTS in order to improve the appearance of the vehicle's side door window frames. The primary design considerations were manufacturability, quality, and integration.

To achieve this goal, tasks including the benchmarking of competitive products, concept generation, weighting of solutions, CAD modeling, and prototyping were completed. Cadillac's reputation as a premier auto brand dictated that the solution meet strict dimensional tolerances and add to the vehicle's overall perceived quality.

...*The Cadillac CTS Student Design Team*



Mr. Skowronski



Ms. Giovanardi



Mr. Hagman



Prof. Loos

The Molding and Appliqué system project provides GM with a complete and integrated global design solution that meets both performance and manufacturing requirements. The project was developed to enable the GM Styling Studio with the flexibility to use their talents to seamlessly integrate the exterior appearance of a vehicle and the engineering community to execute a design that makes a clay model a reality while meeting a high quality standard in a challenging marketplace.

Timothy Skowronski
Side Closures Lead Designing Engineer
General Motors North America Product Development

Project Sponsor
General Motors
Warren, Michigan

Professional Advisors
Ms. Carla Giovanardi
Mr. Dennis Hagman
Mr. Tim Skowronski

Faculty Advisor
Prof. Alfred Loos

Team Members and Home Towns
Matthew Burdick
Grand Rapids, Michigan

Kaitlin Donoughe
Rochester Hills, Michigan

Benjamin Llewellyn
Petoskey, Michigan

Eric Vine
Shelby Twp, Michigan

GENERAL MOTORS COMPANY: RE-DESIGN OF THE CADILLAC SRX TAIL LAMP LOCATING STRATEGY FOR VARIATION

This project is to re-design the attachment strategy of the tail lamp on the 2010 Cadillac SRX. Doing so should improve the robustness of the location of the lamp and create the desired fit between the lamp and the body eliminating the need for post-production adjustments. The new design must account for the pre-assembly variations in both the body and lamp so the lamp fits the visual features of the body as desired. The outside of the lamp is attached to an outside panel of the body while the inside of the lamp is attached to an interior body panel. There is variation between these two body panels, which increases the chance of an imperfect fit.

Several constraints were imposed by *Cadillac* to fit regulations and ensure the Class-A standard to which their luxury vehicles are accustomed. The new design must allow the tail lamp to be fully serviceable with only a flat-head or Phillips-head screwdriver. The fastener location surfaces must be reproducible by injection molding or a similar manufacturing process. Likewise, the mating body sections must also be easily reproducible by their current manufacturing processes. There also can be no visible exterior fasteners, and the cost of the final design must be comparable to the current fastening strategy.

The solution to this problem was produced by a drastic change in the location of the fasteners, as well as different fasteners used. This re-distribution of fasteners optimizes the strength and robustness of the tail lamp while overcoming the variance in the body. Therefore, the tail lamp can be attached directly off the line with no need for post-production adjustment.

...*The Cadillac Student Design Team*



Prof. Hong



Mr. Ply

The New *GM* must exceed the expectations of its customers for quality and excellence in design. To succeed, highly detailed, aggressive designs, like the tail lamps of the SRX, must be able to be executed with tight levels of fit and finish while simultaneously being robust to the normal variation that occurs within a vehicle assembly.

Jon Rich
GM VEC Center



Mr. Rich

Project Sponsor
GM VEC Center
Warren, Michigan

Professional Advisors
Mr. Matt Ply
Mr. Jon Rich

Faculty Advisor
Prof. Soonsung Hong

Team Members and Home Towns
Eric McElmurry
Mason, Michigan

Matt Perelli
Novi, Michigan

John Stukel
Plymouth, Michigan

Sam Tkac
Brighton, Michigan

LOUIS PADNOS IRON & METAL/JOHN BALL ZOO: GEOHERMAL REPLACEMENT OF A CONVENTIONAL CHILLER

The John Ball Zoo Society has been serving Kent County since 1884. John Ball Zoo currently has Michigan's only public aquarium. This aquarium has twelve separate tanks that all require their water to be chilled at a different specific temperature. The current conventional chiller system uses a lot of energy which in turn results in a very costly operation for the zoo.

Padnos Iron & Metal specializes in the recycling and processing of metal, paper and plastic. The proposed geothermal chiller would be constructed from recycled materials provided by *Padnos*.

The John Ball Zoo Society wishes to replace or assist its existing conventional chiller with a geothermal solution that will be used to maintain water temperatures of several aquarium tanks in a more cost efficient and environmentally friendly manner. With the help of *Louis Padnos Iron & Metal*, the project goal is to design a feasible geothermal chilling system that can be tied into the existing pipe and heat exchanger systems.

Many different designs for the new chilling system were investigated including horizontal trench and vertical well ground based heat pump systems. Computer Aided Design programs were used in order to model the designs while the constraints of the zoo's available area as well as the project's budget were met. Specific designs and plans were laid out in order for the John Ball Zoo to take the next step in the implementation and construction of the project should they decide to move forward.

...*The Padnos Iron & Metal/John Ball Zoo Student Design Team*



Mr. Schrottenboer



Mr. Przekadzinski

The research and development of a viable geo-thermal alternative for the existing standard chiller system is intended to provide an economic benefit in the utility cost required to operate the system. The hope is that the more environmentally friendly system also reduces cost through less required maintenance, also lending itself to creating better economic sustainability for the organization.

Craig Schrottenboer
Machine Maintenance General
Manager



Mr. Forrester



Prof. Bénard

Project Sponsors

Louis Padnos Iron & Metal Company
Holland, Michigan

John Ball Zoo Society
Grand Rapids, Michigan

Professional Advisors

Mr. Allmon Forrester
Mr. Martin Przekadzinski
Mr. Craig Schrottenboer

Faculty Advisor

Prof. Andre Bénard

Team Members and Home Towns

Louis Cervone
East Lansing, Michigan

Anthony Dellicolli
Novi, Michigan

Jacob Haf
Novi, Michigan

John Sachs
Farmington Hills, Michigan

GREEN VORTEX: TWO-FLUSH TOILET SYSTEM

Green Vortex is an East Lansing based company dedicated to creating products for a more environmentally conscious society. With ethical principles, *Green Vortex* uses well thought-out engineering practices to implement these eco-friendly ideas. The increasing awareness of water conservation is a priority based on dwindling water supply. A major opportunity for water savings and a resulting financial savings can be found in a commercial bathroom.

The standard US toilet uses 1.6 gallons per flush despite the quantity of waste in the bowl. This amount can be unnecessary for many applications such as children, small adults, miscellaneous minor disposal, and cleaning needs. In a commercial setting, these toilets can be flushed up to 200 times in a day, perhaps more. This creates a large amount of unneeded water treatment and wasted water.

In a large portion of Western Europe, a two-flush toilet system provides the user with a second option that only uses half of the water of a normal flush. This allows for more efficient and effective use of water. Inspired by this system, *Green Vortex* has thought of a unique way to bring this technology to North America.

Through sensor equipment, the amount of waste in the bowl is detected and relayed to a microcontroller. The microcontroller is electrically connected to a standard, automatic flush valve that activates and releases the appropriate volume of water needed to completely remove the substance. This waste removal system can be programmed to operate automatically without user awareness.

...*The Green Vortex Student Design Team*



Dr. Wichman

Green Vortex Engineering is interested in environmentally compatible and friendly solutions to technical engineering problems related to domestic and residential engineering applications. These technical problems include heat transfer and energy usage, cleaning, and waste removal in homes and buildings. Important features of *Green Vortex* Engineering are engineering innovation, high product quality and minimal irreversible spoilage of precious natural resources.



Prof. Mueller

Indrek Wichman
President
Green Vortex

Project Sponsor

Green Vortex
E. Lansing, Michigan

Professional Advisor

Dr. Indrek Wichman

Faculty Advisor

Prof. Norbert Mueller

Team Members and Home Towns

Michikazu Aono
Saline, Michigan

Brandon Hengesbach
Westphalia, Michigan

David, Lantzy
Lansing, Michigan

Bryan Maxwell
Troy, Michigan

MOTOROLA: MOBILE DEVICE WITH A FLEXIBLE DISPLAY

Motorola has been a global communications leader driven by a passion to invent for more than 80 years. *Motorola* has been involved with wireless technology since the beginning, from two-way radio systems to the popular cell phones used today. Presently, the company manufactures a wide range of products from satellite systems to mobile phones. One of *Motorola's* great successes was the release its popular Razer flip-phone. During the first four years of its manufacturing, more than 110 million Razrs were sold.

The project task was to design a new and unique mobile device that takes full advantage of the benefits of a flexible display. Several prototype designs were created, analyzed, and improved upon over the course of the semester. The final product is a mechanically functioning mobile device with a useful flexible display that will carry on *Motorola's* tradition of revolutionizing the way people communicate.

Currently, most mobile devices have glass screens, which limit product design, size, and reliability. Using a flexible display in place of a rigid glass display could enable smaller, lighter, and more unique designs. Research on flexible displays, current cell phone materials, and geometries were performed to develop the most effective and unique design. Many different ideas were brainstormed but through analysis and market research on the best concepts, one design was chosen. Designs were created using computer aided modeling programs and manufactured in *Motorola's* prototyping lab. One of the project goals was for the device to survive *Motorola's* rigorous Accelerated Life Test, which ensures that the product will withstand five years of daily use.

...*The Motorola Student Design Team*



Mr. Wojack

The development of projects aligns with *Motorola's* ambition to develop compelling mobile devices that allow consumers to be more productive. The goal of these projects will be to create a new paradigm for a mobile phone experience.

Mr. Jason Wojack
Motorola



Prof. Patterson

Project Sponsor

Motorola
Libertyville, IL

Professional Advisor

Mr. Jason Wojack

Faculty Advisor

Prof. Eann Patterson

Team Members and Home Towns

Tim Aspinall
Hastings, Michigan

Mike Hines
Shelby Twp., Michigan

Matt Owens
Grand Rapids, Michigan

Ryan Smith
Canton, Michigan

THE MOTOROLA FOUNDATION YOUTH IN ENERGY AND ENVIRONMENT HUMANITARIAN PROJECT: BIOMASS ENERGY DEMONSTRATOR FOR WOODCREEK ELEMENTARY SCHOOL

The *Motorola Foundation* Youth in Energy and Environment Humanitarian Program has been funding design projects at Woodcreek Elementary since the fall of 2007. The goal of the project is to ensure that the next generation of Americans has the technical knowledge necessary to be aware of the energy and environmental issues that impact our world.

With the financial support of the *Motorola Foundation*, the design team at Michigan State University was able to provide the 5th grade students at Woodcreek Elementary with an active learning experience. Woodcreek is located in the Lansing Public School District and is a nationally recognized magnet school in engineering, math, and science. Woodcreek has been a leader in the community in the implementation of green energy and other environmentally friendly practices into the daily routine of the students. In 2008, Governor Jennifer Granholm named the school the first Green School in Michigan. The design team visited Woodcreek multiple times throughout the semester to present topics focusing on biomass energy and engineering. The team also worked with students to design and create a Biomass demonstration device while teaching the design process. This demonstration will be used to teach current and future Woodcreek students, and the exposure to alternative energy will help the students become educated world citizens.

...*The Motorola Foundation Student Design Team*



MOTOROLA



Ms. Graham

This collaborative project between *Woodcreek Elementary* and MSU will have an important impact on the *Woodcreek* students. The hands-on experience and partnership with the MSU Design Team will create a memorable learning environment that will give students a real-world look into engineering and promote curiosity and motivation. Furthermore, the project will give the students an overview of current energy and environmental issues, and solidify *Woodcreek's* place as one of the nation's top Magnet schools.

Diane Graham
Engineering Specialist
Woodcreek Elementary School



Prof. Somerton

Project Sponsors

Woodcreek Elementary School

Lansing, Michigan

Motorola Foundation

Shaumburg, Illinois

Professional Advisor

Ms. Diane Graham

Faculty Advisor

Prof. Craig Somerton

Team Members and Home Towns

Paul Allen
Hudsonville, Michigan

Amber Beebe
Detroit, Michigan

Amy Bittinger
Fenton, Michigan

Caitlin Hojnacki
Commerce Twp., Michigan

Raghav Nanda
New Delhi, India

LEFEVRE CORPORATION: REDESIGN OF GRANULATOR BLADES

Lefevre Corporation is a small business owned by entrepreneur Mark Lefevre, who holds a patent on a machine created to grind up recyclables: the Granulator. This machine granulates scrap rubber and plastic by using a non-rotary system comprised of three stationary plates housing two sliding plates that shred the material. This system generates less heat compared to rotary systems, eliminating the risk of rubber fires. The Granulator is also capable of producing various grain sizes.

The target market for the Granulator is recycling facilities, where it can be used to recycle tires and plastics. The granulated rubber can be used as an ingredient in asphalt for paving roads and the plastic could be used as feedstock for injection molding. This system would be easy to incorporate into current recycling facilities because of its small footprint and minimal power consumption required for operation.

The design challenge was to improve the blade design to incorporate inserts for the cutting surfaces. The previous design contained the plate and cutting surface as one machined piece. The cutting surface of the plate consisted of an oblong section in the middle of the plate that contained an array of closely packed holes for the rubber to fall into and be sheared by the two moving plates. By switching to an insert for the cutting surface, the user can easily change the cutting surface without changing the base plates. This also reduces the cost of sharpening and replacing the blades, which reduces the down time of the machine.

...The Lefevre Corporation Student Design Team



Lefevre corporation



Mr. Lefevre

The cost of machinery is a big factor for any recycling business. If one machine could be made to produce a variety of material output sizes through the use of quick-switch inserts, designed so as to allow the operator to quickly change the output material size as his customer's demands changed, then the need for several expensive pieces of machinery would be eliminated. A recycler would also decrease his capital expenditures while increasing his ability to service multiple markets because the blade system is capable of handling more than one type of material depending on the type of inserts selected. Costs and downtime would be decreased while profits and customer satisfaction would be positively impacted.



Prof. Pence

Mark Lefevre
President
Lefevre Corporation

Project Sponsor
Lefevre Corporation
Grand Ledge, Michigan

Professional Advisor
Mr. Mark Lefevre

Faculty Advisor
Prof. Tom Pence

Team Members and Home Towns
Elizabeth Carroll
Troy, Michigan

Joel Darin
White Lake, Michigan

James Guitar
Kalamazoo, Michigan

Andrew Rogers
Shelby Township, Michigan

TECHMARK: DESIGN FOR IMPROVING AIR EXCHANGE IN POTATO STORAGE

Following harvest, potatoes are cooled and kept in bulk storage for up to 12 months prior to processing. Forced air is used to control the storage conditions but elevated fan speeds coupled with dehumidifying the potatoes leads to inefficient consumption of electricity and product weight loss. The project objective is to use an air, heat, and mass transfer model to design an improved strategy that enables Techmark to input site specific information and optimize fan settings. The recommended ventilation settings must minimize electrical consumption while ensuring maximum potato quality during storage.



Students: Amber Jablonski, Andrew Johnson, Jason McIntyre **Client:** Todd Forbush, Techmark, Inc.
Faculty Advisors: Bradley Marks, Ph.D., P.E. and Fred W. Bakker-Arkema, Ph.D., P.E.

KELLOGG BIOLOGICAL STATION: DESIGN OF AN INTEGRATED ANAEROBIC DIGESTER & TREATMENT WETLAND FOR PASTURED BASED DAIRY FARMS

Pasture based dairy farms produce several waste streams that require management. A comprehensive anaerobic digester coupled with a treatment wetland has been proposed to address all waste management issues on these farms. Prior to implementing these systems, it is necessary to validate that the dual system integration is both feasible and sustainable for a small farm. A model will be developed to optimize waste treatment and biogas production for pasture based dairies. Modeling will be validated using the Michigan State University, Kellogg Biological Station dairy farm as a case study.

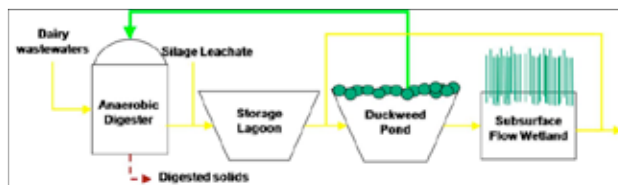

Students: Joseph Ahlquist, Louis Faivor, Patrick Triscari **Client:** Dawn Reinhold, EPA P3: People, Prosperity and the Planet Student Design Competition for Sustainability **Faculty Advisor:** Wei Liao, Ph.D.

BUSK & SUTTON: SUSTAINABLE URBAN GOAT FARM IN DETROIT

The Detroit population has severely declined leading to vacant land and abandoned buildings that are available for development, which includes urban agriculture. Community development projects such as vegetable garden operations provide city beautification, community pride and involvement, and fresh, organic foods to areas that otherwise may not have them. Expanding this urban farm model to livestock provides surrounding communities with fresh milk, cheese, and meat products, increased employment, and opportunities for agricultural education. Goats, which provide similar products to cows and require less space, are a good option for an urban livestock farm. A business model for urban goat farming will be developed that includes animal selection, consumer product constraints, adequate water supply, and environmentally sustainable treatment of animal and process wastes that meet regulatory requirements.



Students: Mike Wandersee, Julio Martinez, John Matolka, Andrew Sommerlot **Clients:** Rebecca Busk and Erin Sutton
Faculty Advisor: Dana Kirk, Ph.D.

ABBOTT: IDENTIFICATION & REPLACEMENT OF CHEMICALS HAZARDOUS TO HUMAN HEALTH AND ENVIRONMENTAL STABILITY

The U.S. Environmental Protection Agency and the European Chemicals Agency, and others, are seeking to prohibit the use of substances that are hazardous to human health or the environment. To reduce time and costs associated with an in depth analysis of each chemical, agencies developed criteria to determine individual risk of each substance. Because the criteria differ between agencies a list of more than 1800 chemicals have the potential to become restricted. Abbott is seeking to determine whether currently regulated substances used in manufacturing practices or packaging, are likely to become restricted and what alternatives are available.



Students: Brandon Coles, Yvette Holly, Dara Phillips **Client:** Abbott **Faculty Advisor:** Evangelyn Alocilja, Ph.D.

MSU-WATER INITIATIVE: STREAM BANK BIOENGINEERING FOR STABILIZATION OF AN URBAN CHANNEL

The Red Cedar River on Michigan State University's (MSU) campus presents signs of riverbank erosion, despite past attempts to stabilize the river with rock riprap. MSU's Institute of Water Research has requested plans and specifications for a pilot-scale stabilization of the Red Cedar River using bioengineering techniques.

Stream bank bioengineering uses biological materials, such as coarse woody debris and living vegetation, to increase the strength and structure of channel slopes. Bioengineering is preferred to satisfy the sustainability initiatives within the MSU Master Plan and enhance the ecological and aesthetic functions of the river.



Students: Natalie Bouchard, Johanna Kinsler, Nancy Maschke, Bradley Wardynski

Client: MSU-WATER Initiative

Faculty Advisor: Dawn Reinhold, Ph.D.



NESTLÉ-GERBER: DESIGN OF AN ASEPTIC PACKAGING ENVIRONMENT FOR LIQUID PRODUCT FILLING

The Nestle-Gerber pilot plant in Fremont, Michigan needs an aseptic process for filling a diverse array of test products into packages that vary in size and shape, from small puree containers to large commercial juice bottles. A three part aseptic packaging box is being designed and constructed that includes three zones, which include packaging entrance and sterilization, filling, and packaging exit.

Packaging sterilization and system validation is the primary focus of the design. The design must exceed the Food and Drug Administration (FDA) and Hazard Analysis for Critical Control Points (HACCP) standards for commercial sterility of packaging and food products. Included, as part of the design, is an automation software operational program and an operation manual with food safety protocols for safe operation, cleaning, and trouble shooting.



Students: Jonathan Biron, Gerald Hessell, Matt Stinson **Client:** Nestlé-Gerber **Faculty Advisor:** Kirk Dolan, Ph.D.



Medtronic

Beyond Imagination

TRANSFORMING TECHNOLOGY TO CHANGE LIVES

At Medtronic, we're changing what it means to live with chronic disease. We're creating therapies that help patients do things they never thought possible. Seeing our work improve lives is a powerful motivator. The more we do, the more we're driven to push the boundaries of medical technology.

To learn more about career opportunities at Medtronic visit www.medtronic.com/careers.

LinkedIn

twitter

facebook

A world leader in automotive parts and accessories

Delphi designs, engineers and manufactures a wide variety of components, integrated systems and modules on a worldwide basis. As the largest and most diversified supplier of automotive parts, Delphi can provide our vehicle manufacturer customers with global, single-point sourcing capability and systems tailored to meet their specific needs.



<http://delphi.com/>

DELPHI | Brake Systems
Automotive Holdings Group



Design Day Awards:

MICHIGAN STATE COLLEGE OF ENGINEERING

Computer Science and Engineering Awards

CSE 498, Collaborative Design, is the senior capstone course for students majoring in computer science. Teams of students design, develop, and deliver a significant software system for corporate clients. The CSE capstone teams compete for four prestigious awards. The winners are selected on Design Day by a panel of distinguished judges.

Auto-Owners Insurance Exposition Award



CSE 498 capstone teams present their projects on Design Day in a variety of ways. Teams create and set up an exhibit where they demonstrate their software systems to and answer questions from Design Day attendees. Each team plays their project videos and answer questions for a panel of judges.

The CSE capstone team with the best overall Design Day performance is honored with the Auto-Owners Insurance Exposition Award, which is sponsored by Auto-Owners Insurance Company of Lansing, Michigan.

Team 2. Auto-Owners Insurance
Telephone Log Self-Service Dashboard



Steve Springer, Michael Eaton, Daniel Chandonnet, Gina Chernoby
Presented by Bob Buchanan and Scott Lake of Auto-Owners Insurance
May 2009

Chrysler Praxis Award



One of the hallmarks of CSE 498 capstone projects is that of praxis, the process of putting theoretical knowledge into practice. Teams apply a wide variety of information technologies to produce solutions to complex problems in areas such as business, engineering, computing, and science.

The CSE capstone team that engineers the software system that is the most technically challenging is recognized with the Chrysler Praxis Award, which is sponsored by Chrysler LLC of Auburn Hills, Michigan.

Team 6. Motorola
User Generated Video Service for Cable Systems



Randy Lyczynski, Bethany Wenzel, Maitland Marsh, Matt Beer
Presented by Karen Wrobel of Chrysler
May 2009

Design Day Awards:

MICHIGAN STATE COLLEGE OF ENGINEERING

Computer Science and Engineering Awards

December 2009 Design Day Judges

David Asiala
Dow Chemical

Richard Enbody
Michigan State University

Adam Haas
Ford

Vandy Johnson
Medtronic, Inc.

Marty Strickler
Rose Packing

Michael Drazan
The Toro Company

Naim Falandino
Covisint

Louise Hemond-Wilson
IBM

Kevin Ohl
Business & Technology Consultant

Karen Wrobel
Chrysler LLC

Crowe Horwath Sigma Award



The CSE 498 experience represents the capstone of the educational career of each computer science major. An intense semester of teamwork produces impressive deliverables that include a formal technical specification, software, documentation, user manuals, a video, a team web site, and Design Day participation. The resulting sum, the capstone experience, is much greater than the parts.

The capstone team that delivers the best overall capstone experience is recognized with the Crowe Horwath Sigma Award, which is sponsored by Crowe Horwath LLP of Oak Brook, Illinois.

Team 10. Urban Science Web-Based Geography Management



Jeffrey Smith, Jason Weber, Jeremy Kocks (Not Pictured)
Presented by Alex Keefe of Crowe Horwath
May 2009

TechSmith Screencast Award



Each CSE 498 capstone team produces a video that describes and demonstrates their software product. Starting with a storyboard and a script, teams use Camtasia Studio 5 to synthesize screen recordings, video, audio and other multimedia to produce their project videos.

And the TechSmith Screencast Award goes to...the CSE capstone team with the best project video. The award is sponsored by the creators of Camtasia Studio, TechSmith of Okemos, Michigan.

Team 4. Ford Ford Conference Room Monitor



Gregory Kent, Lauri Marc Ahlman, Nicholas Stumpous, Michael Peteuil
Presented by Dean Craven of TechSmith
May 2009

Design Day Awards:

MICHIGAN STATE COLLEGE OF ENGINEERING

Mechanical Engineering: Thomas Alva Edison Undergraduate Design Award

The Edison Scholars are recognized as the ME 481 Design Team that has produced the most outstanding project. A jury of experts from industry and academia evaluate the final reports, the posters, and the final oral presentations in determining the award winners. Teams operating under ME 481 that include members from other departments and colleges are also eligible for this award. The funding for this award is provided by the Shell Oil Company.



l-r: Professor Somerton, Ryan McPhee, Brent Rowland, Kevin McPhail, Muhammad Nabeel Aslam, Eric Tingwall

SPRING 2009 ME 481 EDISON UNDERGRADUATE DESIGN AWARD

First Place

*The Somerton Family Trust
Humanitarian Project for Developing
Countries: A Vaccine Refrigerator for
Remote Regions with The Appropriate
Technology Design Collaborative*
Kevin McPhail
Muhammad Nabeel Aslam
Eric Tingwall
Brent Rowland
Ryan McPhee

Second Place

*American Hydromech:
"Value Line" Series of
Hydraulic Filters
with Flow Indicator*
Matthew Wolf
Andrea Vivian
Bryant Ennis
Ryan Blake

Third Place

*Phoenix Composite
Solutions: Low Cost
Wind Turbine*
John Tysman
Lauren Heitzer
Kyle Elliott
Jeffrey Elberling
Brian Steffes

ME 481 Oral Presentation Award

The best ME 481 oral presentation as determined by the ME 481 students is recognized with this award.



*l-r: Professor Somerton,
Christopher Miller,
Fadi Yousif, Lisa
Chapman, Zef Ivanovic*

SPRING 2009 ME 481 ORAL PRESENTATION AWARD

First Place

*Blue Sky Chicago:
Unmanned Food Demo
System (Green Team)*
Christopher Miller
Lisa Chapman
Fadi Yousif
Zef Ivanovic

Second Place

*American Hydromech:
"Value Line" Series of
Hydraulic Filters with
Flow Indicator*
Matthew Wolf
Andrea Vivian
Bryant Ennis
Ryan Blake

Third Place

*Padnos Iron & Metal
Co.: Gaylord Box
Rotor for Hilo
Rollover System*
Peter Mott
Adam Smith
Tyler Grab
Anthony Carlo

ME 481 Outstanding Poster Award

The ME 481 Outstanding Poster Award recognizes the best poster presented by an ME 481 design project team as judged by a team of individuals from industry and academia. Judging is based on both technical content and aesthetic layout.



*l-r: Professor Somerton,
Ryan Kelly,
Marcus Peters,
Brent Augustine*

SPRING 2009 ME 481 POSTER PRESENTATION AWARD

First Place

*The Motorola Foundation
Youth in Energy and
Environment Humanitarian
Project: Wind Demonstrator
Power for Woodcreek
Elementary School*
Brent Augustine
Ryan Kelly
Marcus Peters
Christopher Gandy

Second Place

*A Humanitarian
Project for People with
Disabilities: A Mobility
Device for John Montalvo
with the Montalvo Family*
Clifford Carlson
Craig Helewski
Kevin McAlpine
Michelle Raetz

Third Place

*Renee Reynolds and
Michelle Gruender: Urban
Shopping Cart*
Adam Alderman
Logan Beam
David Cain
Michael Maurer

Design Day Awards:

MICHIGAN STATE COLLEGE OF ENGINEERING

Leonardo daVinci Scholars



l-r: Mr. Isaac, Stephanie Bonner, Kaitlin Donoughe, Brandon Uhl, Steve Hukill

The student team members winning the ME471 competition at Design Day are recognized as Leonardo DaVinci Scholars. The award winners are determined by the course instructors based on team scoring in the competition. The funding for this award is provided by the Shell Oil Company.

SPRING 2009 ME 471 MECHANICAL DESIGN AWARD

First Place

Kaitlin Donoughe
Steve Hukill
Brandon Uhl
Stephanie Bonner

Second Place

Elizabeth Carroll
Marshall Mendoza
Drew Darling
James Guitar

Third Place

Amanda Ruhno
Nick Shock
Mike Karoub
Ryan Wood

ME 456 Mechatronics Systems Design Commercial Mechatronic Prototype Award

The best ME 456 project is recognized with this award. The award winners are determined by the course instructor.



Professor Radcliffe, Kevin Derrick, Xiaojian Yang, David Cain, Jonathan Luckhardt

Fall 2008 ME 456 MECHATRONIC PROTOTYPE AWARD

First Place

David Cain
Kevin Derrick
Jonathan Luckhardt
Xiaojian Yang

ME 412 Heat Transfer Laboratory Heat Transfer Design Award

The student team members winning the ME 412 competition at Design Day are recognized by the Heat Transfer Design Award. The award winners are determined by the course instructor based on team scoring in the competition.



l-r: Professor Somerton, Dr. Genik, Jacob Haf, Anthony Dellicolli, John Sachs

SPRING 2009 ME 412 HEAT TRANSFER DESIGN AWARD

First Place

Anthony Dellicolli
Jacob Haf
John Sachs

Lowest Temperature

Gregory Pelkie
Daniel Schleh
Ryan Smith

Most Creative

Joshua Davis
Stephen Hammack
Kevin McAlpine

ME 371 Mechanical Design I Kids' Choice Award

The pre-college students participating in Design Day vote for the most outstanding ME 371 project. The winning team is designated as the Kids' Choice Award. This team is recognized with a plaque designed and manufactured by Mr. Jon Thon's 7th grade technology class at Holt Junior High School.



l-r: Mark Goldy, Professor Thompson, Mark Holmes, Nicholas Stuart, Diana Toan

SPRING 2009 ME 371 KIDS' CHOICE AWARD

First Place

The Bagel Mangler
Mark Goldy
Mark Holmes
Nicholas Stuart
Diana Toan

Second Place

Smash Factory
Hasib Mohammed
Alexandre Oliveira
Stephen Santavicca
Andrew Tonkovich

EGR 100 Outstanding Prototype and Poster Award

The EGR 100 Outstanding Poster and Prototype Award recognizes the best project presented by an EGR 100 design team as judged by area middle and high school students.

SPRING 2009 EGR 100 OUTSTANDING PROTOTYPE AND POSTER AWARDS

First Place

Andrew Mozer
Chaoran Sun
Mohammed Asif Syedmakandar

Second Place

Riti Adhi
Charmane Carruthers
Laura Longworth

Design Day Awards:

MICHIGAN STATE COLLEGE OF ENGINEERING

Electrical and Computer Engineering Prism VentureWorks Prize and Winners, Spring2009

The Prism VentureWorks Prizes (\$1,500, \$1,000, and \$500, respectively) are awarded each semester to the most outstanding teams in the Electrical and Computer Engineering Senior Capstone Design Course, as judged by a panel of engineers from industry. A team with members from both ECE and another engineering major (mechanical engineering, for example) is also eligible, if the team's project is administered through ECE 480. The prizes are sponsored by Prism VentureWorks, a Boston-based venture capital firm, and Mr. William Seifert, an ECE alumnus, who is a partner in that firm. The faculty and students of Electrical and Computer Engineering are very grateful for this generous support.

First Place: Team #6 –“Automated Inspection Device for Electronic Fan Clutch Actuators”
(Sponsor: Borgwarner)



LEFT TO RIGHT:
Steven Sutara, Codie Wilson, Joshua DuBois,
Jacob Co, Dr. Erik Goodman

Second Place: Team #2 –“Locally Networked Satellite-Based Computer Labs for Tanzanian Classrooms”
(Sponsor: Lenovo Corporation) and **Team #3 –“Home Automation HMI Demo”**
(Sponsor: Texas Instruments)



LEFT TO RIGHT:
Steven Sadler, Kevin Bishop, Daniel Newport,
Brian Holt, Dr. Erik Goodman



LEFT TO RIGHT:
Rituraj Behera, Da Ke, Eric Myers, Samuel Flynn,
Dr. Erik Goodman. (Not pictured: Sung Soo Kim)

Design Day Awards:

MICHIGAN STATE COLLEGE OF ENGINEERING

Professor's Choice Award and Winner, Spring 2009

The Professor's Choice Award (\$1,000 and a certificate) is given each semester by the faculty member teaching ECE 480, Senior Capstone Design, to the team judged to have done the most to achieve the objectives of the course and sponsor, particularly taking into account the varying levels of challenge of the projects assigned. Judging is based on reading of the teams' final reports, examination of their posters/prototypes, and communication with their faculty facilitators.

Team #1 – “Heat-Reactive Clothing Electric Wheelchair Accessory” (Sponsor: Chrysler Foundation)



LEFT TO RIGHT:
Albert Alexander, Steven Shane,
Stephen Zajac, Dr. Erik Goodman.
(Not pictured: Melissa Stroud)

Electrical and Computer Engineering Capstone Poster Award and Winner, Spring 2009

Each team in ECE 480, Senior Capstone Design, exhibits a poster and the items they have built during the semester and answers questions, from 8:00am-noon in the Union Ballroom. Judging of the best poster/demo is done by the groups of high school students participating in Design Day, based on their appeal and effectiveness in communicating the project goals and achievements. A prize of \$1000 is awarded to the most outstanding team.

Team #1 – “Heat-Reactive Clothing Electric Wheelchair Accessory” (Sponsor: Chrysler Foundation)



LEFT TO RIGHT:
Albert Alexander, Steven
Shane, Stephen Zajac,
Dr. Erik Goodman. (Not
pictured: Melissa Stroud)

Civil Engineering Senior Design Award

The Civil Engineering Senior Design Award (\$600 and plaques) is presented to the best team in CE 495 as judged by the faculty and a panel of practicing engineers.

Each student participates on a team which, as a collective unit, is responsible for preparing a project design. Individual student's are each responsible for one technical area (environmental, geotechnical, hydrological, pavements, transportation, or structures) or they serve as the team's project manager. Project managers prepare their team's non-technical report while the other team members each write a technical report covering their area of responsibility. Midway through the semester, each student meets one-on-one with a practicing professional engineer to summarize his/her progress and discuss the project. The final technical reports are judged by faculty and the oral presentations of each team's overall design are judged by a board of six practicing professional engineers.

The faculty and students of the Department of Civil and Environmental Engineering gratefully acknowledge the generous contributions from Fishbeck, Thompson, Carr & Huber, Inc. (FTC&H) and from Barr Engineering Co. These companies currently make this award possible. FTC&H is a professional civil engineering, environmental consulting, architectural/engineering, and construction management firm with clients in Michigan and throughout the nation. Barr Engineering is a professional engineering company providing engineering, environmental, and information technology services to clients across the nation and around the world.



Middle & High School Innovation & Creativity Day

December 11th, 2009

WIRELESS INTEGRATED MICROSYSTEMS (WIMS) DIGITAL THERMOMETER BUILD



This build is specifically designed to introduce pre-college students to electronics theory and application. In this session students will learn to identify numerous electronic components. They will be taught how to properly handle and place the array of components onto the Printed Circuit Board (PCB). Once the components are located, proper soldering

techniques will be used for final assembly. When the thermometer is completed, students will have an opportunity to learn how to properly calibrate their thermometers. Throughout the build, MSU faculty and engineering students will help students test and trouble-shoot as needed. Upon successful completion of this session, each school will have a classroom set of thermometers to enhance mathematics and science activities within their school's curriculum.

NXT ROBOTICS



Our team of experts has designed a lab experience to give pre-college students an introduction to robots. Students will learn to program robots using the

LEGO NXT Mindstorm Robot. Using the graphical software (NXT G), students will write programs to control their group's robot. Application and discovery of how programming works will be similar to lessons presented in science and math classes. Each team will discover how to adjust their programs based upon the program inputs and actual output (robot performance). During each phase, new challenges will be introduced to engage the students. This will reinforce new ideas and concepts while exposing students to the newly emerging capabilities of student-controlled robotics programs.

SCIENCE & ENGINEERING FOR A NEW ENERGY INFRASTRUCTURE: FUTURE FUELS

As demand for fossil fuels increases in almost every corner of the world the environmental impact of combustion becomes more apparent. This reality creates an unprecedented need for technological advances which can provide energy from alternative sources and reduce our dependence on foreign oil. This presentation will show why today's energy issues are so important, provide insight into key problems, and examine how science and engineering can bring profound changes.



The first part of the presentation will focus on the technical innovations related to the evolution of human civilization and the need for a revolutionary change in our energy infrastructure. The second part of the presentation will provide an in-depth perspective of the energy issue and why it is so important to our nation. In conclusion, we will discuss potential solutions which can bring alternative and renewable energy into our everyday lives. Integrated in this presentation LEGO Renewable Energy demonstrations will be given by the curriculum designers.

	Future Fuels & Renewable Energy Parlor C – 2nd Floor	Civil and Robotic Engineering Green Room – 2nd Floor	Digital Thermometer Build Parlor B – 2nd Floor	Engineering Display Voting First Floor	Teacher RET Seminar Tower Room - 4th Floor
8:50–9:40			Session C SessionD	Session A Session B	Invited teachers
9:45–10:35	Session A Session B			Session C SessionD	Invited teachers
10:40–11:15	Session C SessionD	Session A Session B			Invited teachers
11:20–12:00		Session C SessionD	Session A Session B		Invited teachers

All students will report to parlor C promptly at 12:00 for the Awards Ceremony. Lunch will immediately follow

CIVIL ENGINEERING TOWER BUILD

Humans have been building towers since we first started erecting structures thousands of years ago. Are the pyramids simply towers with wide bases necessary to support such structures of tremendous weight? Towers also hold up bridges such as the Mackinac and Golden Gate. Towers like the Sears Tower in Chicago are capable of housing offices, businesses, and living spaces. We also use towers to project radio signals beyond the curvature of the earth. This is accomplished by broadcasting the signal from a great height. The higher the tower, the greater the distance the signal is broadcast without interference from the Earth. This brings us to our challenge today. Given

limited amounts of space and material, how does an engineer design a tall tower that is able to support a load while remaining stable? You and your team will need to figure this out!



TEACHER (RET) SEMINAR - NEW SESSION



With recent NSF Research Experience for Teachers SITE Grant, we are initiating a new session to enhance the integration of Design Day activities into the school curriculum. In this session the Outreach and Research Experience for Teacher (RET)

coordinators will present ways to integrate Renewable Energy into your curriculum. The focus will be on utilizing the LEGO Renewable Energy curriculum as the foundation. Teachers will also have an opportunity to see how these activities will meet current science standards. Additionally, information regarding becoming an RET candidate will be discussed and contact information for interested teachers will be collected. Lastly, we will be looking at ways to integrate the use of the digital thermometers into your existing curriculum. (These are the thermometers the students are building at Design Day.) At the close of this session teachers should have relevant lessons to take back to use in their classes.

VOTING/COLLEGE OF ENGINEERING OBSERVATION

Students will engage in viewing and voting on engineering student design projects and interact with various engineering student organizations.

MEMBERS OF THE ORGANIZING COMMITTEE



Drew Kim
MSU Engineering
Assistant to the Dean
Recruitment, Scholarships,
and K-12 Outreach



Jamie Lynn Marks
MSU Engineering
Recruitment and
K-12 Outreach



Russ Pline
Okemos High School
and MSU Design Day
Coordinator



Bob Watson
MSU Engineering
K-12 Outreach
LEGO and VEX
Robotics Coordinator



John Thon
Holt Junior
High School and
MSU NSF RET
SITE Lead

"Our future lies in some very precious hands..."

Our children are our future. Without the next generation of engineers, scientists and other professionals, the advances we enjoy today would quickly grind to a halt.

At the Dart Foundation, we are committed to developing scientifically literate students in Michigan. Therefore we are delighted to help fund the MSU Department of Mechanical Engineering's Design Day for pre-collegiate students.

An investment in our children's future will pay big dividends for this generation, and also generations yet unborn, in Michigan, America and ultimately the world.

THANKS TO NORFOLK SOUTHERN



The Department of Electrical and Computer Engineering thanks Norfolk Southern for its generous financial support of Design Day. This support was used for production of this program and for other costs associated with Design Day, and for the infrastructure that allows our ECE Senior Capstone Design teams to work effectively on their industry problems.

Norfolk Southern Railway has a proud history, and today's NS includes not only the Norfolk and Western Railway and Southern Railway from which its name arose, but also all or large parts of many other historic railroads, such as the Pennsylvania Railroad, Nickel Plate Road, and Conrail. We are proud to have Norfolk Southern as a sponsor of Design Day! They recruit engineers (not locomotive engineers, but electrical engineers, computer engineers, etc.) at Michigan State University.



The Future of Transportation



Design Day:
December 11, 2009
8 a.m. until 1 p.m.

Second Floor Concourse:
Come hear and see all that we have done this semester.

OUR HISTORY:

Fall of 2006 a small group of engineers founding Audio Enthusiasts and Engineers, an organization open to all Michigan State University students. The first semester AEE designed and built their first masterpiece 'Revolution Audio', a stereo system engineered to produce true stereo sound regardless of which direction the listener is facing. AEE has become one of the most active student organizations in the College of Engineering. Its members are devoted to understanding audio concepts, as well as finding inventive ways to implement this knowledge. aeemsu@gmail.com



THEREMIN

Building a Theremin has shown how specialized oscillating circuits using the heterodyning principal can be used to create some very unique audio devices.



GUITAR PEDALS

Along with our Tube Amps a team built an assortment of Guitar Pedals. Members of this team learned research skills and how to use schematics and a soldering iron.



MOLDED EARBUDS

This team has been working to design and build in-ear headphones with mics on the outside to capture and listen to sound exactly as someone would live. Our members have learned valuable skills in research and development.



TUBE AMPS

This semester the Tube Amp Team built a variety of guitar amplifiers. Those involved in the Tube Amp Team quickly become knowledgeable about reading schematics, component layout, grounding and especially soldering.

**For information on
sponsoring Design Day
and design projects, contact**

Maureen Blazer-Adams
Coordinator, Design Day
2244 Engineering Building
Michigan State University
East Lansing, Michigan 48824
(517) 432-6583
adamsme@msu.edu

MICHIGAN STATE

UNIVERSITY